



(51) International Patent Classification:  
*H02K1/27* (2006.01)

(21) International Application Number:  
PCT/IB2015/001437

(22) International Filing Date:  
23 April 2015 (23.04.2015)

(25) Filing Language: English

(26) Publication Language: English

(72) Inventor; and

(71) Applicant : PARAMAHAMSA, Tewari [IN/IN]; Venodini Nivas, P.O Gotegali, 581 317 Karwar (IN).

(81) Designated States (unless otherwise indicated, for every kind of national protection available): AE, AG, AL, AM, AO, AT, AU, AZ, BA, BB, BG, BH, BN, BR, BW, BY, BZ, CA, CH, CL, CN, CO, CR, CU, CZ, DE, DK, DM, DO, DZ, EC, EE, EG, ES, FI, GB, GD, GE, GH, GM, GT, HN, HR, HU, ID, IL, IN, IR, IS, JP, KE, KG, KN, KP, KR, KZ, LA, LC, LK, LR, LS, LU, LY, MA, MD, ME, MG,

MK, MN, MW, MX, MY, MZ, NA, NG, NI, NO, NZ, OM, PA, PE, PG, PH, PL, PT, QA, RO, RS, RU, RW, SA, SC, SD, SE, SG, SK, SL, SM, ST, SV, SY, TH, TJ, TM, TN, TR, TT, TZ, UA, UG, US, UZ, VC, VN, ZA, ZM, ZW.

(84) Designated States (unless otherwise indicated, for every kind of regional protection available): ARIPO (BW, GH, GM, KE, LR, LS, MW, MZ, NA, RW, SD, SL, ST, SZ, TZ, UG, ZM, ZW), Eurasian (AM, AZ, BY, KG, KZ, RU, TJ, TM), European (AL, AT, BE, BG, CH, CY, CZ, DE, DK, EE, ES, FI, FR, GB, GR, HR, HU, IE, IS, IT, LT, LU, LV, MC, MK, MT, NL, NO, PL, PT, RO, RS, SE, SI, SK, SM, TR), OAPI (BF, BJ, CF, CG, CI, CM, GA, GN, GQ, GW, KM, ML, MR, NE, SN, TD, TG).

**Declarations under Rule 4.17:**

— of inventorship (Rule 4.17(iv))

**Published:**

— with international search report (Art. 21(3))

(54) Title: HIGH EFFICIENCY ALTERNATING CURRENT GENERATOR

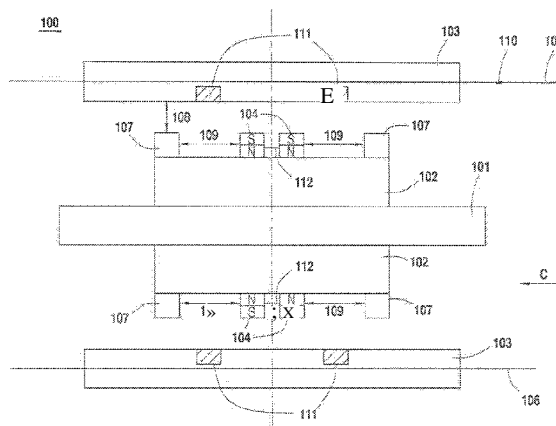

FIG. 1

(57) Abstract: A high efficiency alternating current generator including a hollow stator core, a cylindrical rotor within the stator, a freely rotating shaft coupled to the rotor, a first set of magnets in which the south pole of each magnet is coupled to the surface to the rotor and the north pole of each magnet is facing the inner surface of the hollow stator core, a second set of magnets in which the north pole of each magnet is coupled to the surface of the rotor and the south pole of each magnet is facing the inner surface of the hollow stator core and a set of silicon steel pieces coupled to the outer surface of the rotor comprised of individual silicon steel pieces positioned adjacent to and longitudinally in line with each individual magnet within the first set of magnets and each individual magnet within the second set of magnets.



WO 2016/170384 A1

## HIGH EFFICIENCY ALTERNATING CURRENT GENERATOR

### FIELD OF THE INVENTION

[0001] The present invention relates to a rotating alternating current generator whose structural characteristics provide for an increase in efficiency by reducing the amount of electromagnetic back torque resulting from induced current within the winding of the generator.

### BACKGROUND OF THE INVENTION

[0002] Michael Faraday discovered the principles of electromagnetic induction and invented the rotating electrical generator in 1832. The generator was known as the Unipolar Generator, Acyclic Generator and Disk Generator. This generator operated on the principle that voltage is induced in a conductor that is in relative motion to an external magnetic field. Moreover, when the conductor is configured as a closed circuit and is in relative motion to an external magnetic field, a current will be induced to flow through that circuit. However, the induced current itself will generate an induced magnetic field surrounding the conductor. The direction of the induced current may be determined by Fleming's Right Hand Rule which states that the magnetic field produced by the current induced in the conductor will repel the external magnetic field which actually induced that current in the conductor. As such, the induced magnetic field surrounding the conductor and the external magnetic field repel each other so as to create a torque on the conductor which counters that conductor's movement relative to the external magnetic field. Faraday's generator and all subsequent generators have in common the production of this counter or back torque.

[0003] The efficiency of an electrical generator is governed by mechanical and electrical limitations. The mechanical limitations include windage and friction of the generator's rotor and bearings. The electrical limitations include electrical impedance within the windings of the generator as well as the above-described counter or back torque.

[0004] A prime mover is attached to a generator so as to cause the rotation of the generator's rotor resulting in the production of either a direct or an alternating current within the generator's embedded winding. As discussed above, a back torque which counters the rotation caused by the prime mover is also generated. The prime mover may be powered by steam, wind or water or any other method known to one of ordinary skill in the art.

[0005] Therefore, one problem with standard generators is that their efficiency is limited due to a back torque generated as a result of current induced within the generator's embedded winding.

### DEFINITIONS

[0006] The following definitions are provided for convenience and are not to be taken as a limitation of the present invention.

[0007] Fleming's Left Hand Rule refers to the effect that when a current flows in a conductor and an external magnetic field is applied across that current flow, the conductor will experience a force perpendicular to both the external magnetic field and the direction of the current flow. Using this rule, the left hand is used to represent three mutually orthogonal axes in which the thumb represents the direction of an induced torque on the conductor, the first finger represents the direction of a magnetic field applied to the conductor and the middle finger represents the direction of the current within the conductor.

[0008] Fleming's Right Hand Rule refers to the effect that when a conductor moves inside a magnetic field, there will be a current induced in that conductor. Using this rule, the right hand is used to represent three mutually orthogonal axes in which the thumb to represent the direction of a force on the conductor, the first finger represents the direction of the magnetic field applied to the conductor and the middle finger represents the direction of the induced current with the conductor.

[0009] A synchronous generator refers to an electrical generator which turns at the same speed as its drive mechanism, also known as the synchronous speed. A synchronous

generator produces an alternating current and voltage at a frequency proportional to the rotation speed and to the number of excitation poles internal to the generator.

**[0010]** An asynchronous generator refers to an alternating current generator that uses the principles of induction to produce power. Asynchronous generators operate by mechanically turning their rotor faster than the synchronous speed, giving negative slip.

**[0011]** Low carbon steel refers to steel containing less carbon than other steels. This steel is inherently easier to cold-form due to its soft and ductile nature.

**[0012]** Grain oriented electrical steel refers to sheet steel used for laminations in power transformers having a silicon level of 3% or less.

### **SUMMARY OF THE INVENTION**

**[0013]** It is the primary purpose of the present invention to obviate the above problems by providing a reduced reaction rotating alternating current generator providing improvement in efficiency characteristics not currently available in standard alternating current generators.

**[0014]** To accomplish this objective, according to one embodiment of the present invention a high efficiency alternating current generator is disclosed comprising a high efficiency alternating current generator, comprising a hollow stator core having an axis comprised of laminated sheets of high permeability magnetic steel positioned longitudinally, the laminated sheets including longitudinally embedded slots in which a conductor winding is laid parallel to the axis, a cylindrical rotor concentric with and positioned inside the hollow stator core comprised of a high permeability magnetic material, a shaft coupled to the rotor and driven by an external source so as to freely rotate the rotor relative to the hollow stator core, a first set of magnets in which the south pole of each magnet is coupled to the surface to the rotor and the north pole of each magnet is facing the inner surface of the hollow stator core, a second set of magnets in which the north pole of each magnet is coupled to the surface of the rotor and the south pole of each magnet is facing the inner surface of the hollow stator core and a set of silicon steel pieces coupled to the outer surface of the rotor comprised of individual silicon steel pieces

positioned adjacent to and longitudinally in line with each individual magnet within the first set of magnets and each individual magnet within the second set of magnets.

**[0015]** In addition to the foregoing, other features, objects and advantages of the present invention will become apparent from the following description.

### **BRIEF DESCRIPTION OF THE DRAWINGS**

**[0016]** The following detailed description, given by way of example and not intended to limit the present invention solely thereto, will best be appreciated in conjunction with the accompanying drawings in which:

**[0017]** Figure 1 depicts a longitudinal cross-sectional view of a high efficiency alternating current generator according to an exemplary embodiment of the present invention;

**[0018]** Figure 2A depicts a center cross-sectional view of a high efficiency alternating current generator according to an exemplary embodiment of the present invention;

**[0019]** Figure 2B depicts the structure of the longitudinally placed silicon steel laminates which comprise the stator of a high efficiency alternating current generator in accordance to an exemplary embodiment of the present invention;

**[0020]** Figure 3 depicts an end cross-sectional view of a high efficiency alternating current generator according to an exemplary embodiment of the present invention;

**[0021]** Figure 4 depicts a longitudinal cross-sectional view of the flow of magnetic fields emanating from the first set of magnets within a high efficiency alternating current generator according to an exemplary embodiment of the present invention;

**[0022]** Figures 5 and 6 depict the interaction between the magnetic flux originating from the north poles of the first set of magnets and the magnetic flux resulting from an induced current in the conductor winding of a high efficiency alternating current generator according to an exemplary embodiment of the present invention;

[0023] Figure 7 depicts a longitudinal cross-sectional view of the flow of magnetic fields emanating from the second set of magnets within a high efficiency alternating current generator according to an exemplary embodiment of the present invention; and

[0024] Figures 8 and 9 depict the interaction between the magnetic flux originating from the north poles of the second set of magnets and the magnetic flux resulting from an induced current in the conductor winding of a high efficiency alternating current generator according to an exemplary embodiment of the present invention.

### **DETAILED DESCRIPTION OF THE INVENTION**

[0025] The present invention relates to a high efficiency alternating current generator providing improvement in efficiency characteristics not currently available in standard alternating current generators.

[0026] In Figure 1, a longitudinal cross-sectional view of a high efficiency alternating current generator according to an exemplary embodiment of the present invention is depicted. As shown in Figure 1, the generator 100 includes a shaft 101, a rotor 102, a stator 103, a first set of magnets 104, a second set of magnets 105 (not shown), a conductor winding 106 and silicon steel pieces 107.

[0027] The rotor 102 is cylinder shaped and made of a high permeability magnetic material. It is attached directly to the shaft 101 using any conventionally known method that will provide for a secure and permanent bond under normal operating conditions. The rotor 102 is sized to be fully encompassed within the stator 103 while the shaft 101 is sized to extend beyond at least one end of the stator 103.

[0028] The shaft 101 is mounted within the stator 103 so as to allow the shaft 101 and the attached rotor 102 to rotate freely within the stator 103 when the shaft 101 is driven by an external drive source or prime mover. The external drive source is coupled to one end of the shaft 101 that extends beyond the stator 103. The external drive source may be driven either at a variable speed or at a synchronous speed. As such, the drive source may be based on an

alternating current (AC) source or a direct current (DC) source. The drive source may also be based a non-electric drive source such as a hydro, wind or an internal combustion source. The means of coupling the drive source to the shaft 101 will be dependent on the type drive source. As such, any conventionally know method of coupling a specific drive source type may be used that will provide for a secure and dependable coupling under normal operating conditions.

**[0029]** In an exemplary embodiment, the shaft may be manufactured from 80 mm diameter 1018 steel, the rotor from 370 mm diameter 1018 steel and the stator may have a 555 mm diameter.

**[0030]** Provisions are made on the cylindrical surface of the rotor 102 to mount the first set of magnets 104 and the second set of magnets 105 onto the rotor 102. Any conventionally known method may be used to mount the magnets to the rotor that will provide for a secure and permanent bond under normal operating conditions. Each side of the rotor 102 about its midpoint contains a first set of magnets 104 positioned near the midpoint of the rotor 102, each magnet in the first set of magnets 104 offset 180 degrees from each other. The first set of magnets 104 are oriented with their south poles facing the stator 103 and their north poles bonded to the rotor 102.

**[0031]** Similarly, each side of the rotor 102 about its midpoint also contains a second set of magnets 105 (see Figure 2) positioned near the midpoint of the rotor 102, each magnet in the second set of magnets 105 offset 180 degrees from each other. The second set of magnets 105 are oriented with their north poles facing the stator 103 and their south poles bonded to the rotor 102.

**[0032]** The first set magnets 104 and the second set of magnets 105 are positioned on each side of the rotor 102 such that magnets from the same set are longitudinally in line with each other across the midpoint of the rotor 102. Moreover, the first set of magnets 104 and the second set of magnets 105 are also positioned to be angularly offset by 90 degrees from neighboring magnets on the same side of the rotor 102. Corresponding magnets from the first set of magnets 104 and from the second set of magnets 105 on each side of the rotor 102 about its midpoint are aligned with each other and separated by a defined distance 112 across the midpoint

of the rotor 102. As such, in this configuration, each side of the rotor 102 about its midpoint contains of four magnets and the rotor 102 in total contains eight magnets.

**[0033]** The first set of magnets 104 and the second set of magnets 105 may be either permanent magnets or electromagnets. In an exemplary embodiment using permanent magnets or in an exemplary embodiment using electromagnets, the magnets have a flux density greater than or equal to one Tesla and are mounted radially onto the rotor in a manner generally known in the industry.

**[0034]** Further provisions are made on the cylindrical surface of the rotor 102 to mount the silicon steel pieces 107 onto the rotor 102. Any conventionally known method may be used to mount the silicon steel pieces 107 to the rotor that provides for a secure and permanent bond under normal operating conditions. There is a single silicon steel piece 107 corresponding to each magnet attached to the rotor 102. The silicon steel pieces 107 are positioned near both ends of the rotor 102 in line with a corresponding magnet. The silicon steel pieces 107 are also positioned to provide for a predefined distance 109 between a silicon steel piece 107 and its corresponding magnet. Each silicon steel piece 107 is comprised of silicon steel that is specially tailored to have a small magnetic hysteresis area and high magnetic permeability.

**[0035]** In an exemplary embodiment, a high magnetic permeability is defined as a magnetic saturation level above 1.8 Teslas. Furthermore, in an exemplary embodiment, the first set of magnets 104, the second set of magnets 105 and the silicon steel pieces 107 are each sized to have approximately the same surface area. Moreover, in the exemplary embodiment, the distance 109 between each silicon steel piece 107 and its corresponding magnet is no more than what is required to prevent leakage flux from the magnets to the silicon steel pieces. Lastly, in the exemplary embodiment, the distance 112 between corresponding magnets on each side of the rotor 102 about its midpoint is 6 mm.

**[0036]** The rotor 102, the mounted first set magnets 104, the second set of magnets 105 and the steel pieces 107 are all sized to provide for an air-gap 108 of a predefined distance between the upper surfaces of the attached first magnets 104, second magnets 105 and silicon



steel pieces 107 and the inner surface of the stator 103. The air gap 108 is sized to provide for the free rotation of the rotor 102 within the stator 103. Moreover, the air gap 108 must also provide for the efficient flow of magnetic flux between the rotor 102 and the stator 103, the magnetic flux originating from the first set of magnets 104 and the second set of magnets 105 mounted on the rotor 102.

**[0037]** In an exemplary embodiment, the air gap 108 distance is within a range of about 3 mm.

**[0038]** The stator 103 is composed of longitudinally placed silicon steel laminates with grains oriented parallel to the path of the magnetic flux within the stator 103. The stator 103 also includes longitudinally oriented slots in which the conductor winding 106 is laid, the conductor winding 106 positioned so as to be cut through by the rotating magnetic flux originating from the first set of magnets 104 and the second set of magnets 105 mounted onto the rotor 102. Moreover, the stator 103 is constructed to include stator slots 111 running axially for 360 degrees within the stator and positioned at points in between a silicone steel piece 107 and a magnet. Each stator slot 111 originates from the inner surface of the stator 103 and extends upward towards the upper surface of the stator 103 for approximately half the width of the stator 103. The stator slots 111 guide the magnetic flux originating from the first set of magnets 104 and from the second set of magnets 105 further upward and deeper into the stator 103 and thereby cutting across a larger area of the embedded winding 106.

**[0039]** In an exemplary embodiment, the stator is comprised of a non magnetic insulating material of suitable strength to support grain oriented steel lamination sheets, such as PVC piping. Moreover, in the exemplary embodiment, the magnetic flux emanating from the first set of magnets 104 and from the second set magnets is approximately 10,000 Gauss.

**[0040]** In Figure 2A, a center cross-sectional view of a reduced reaction alternating current generator according to an exemplary embodiment of the present invention is depicted. As shown in Figure 2A, the first set of magnets 104 with their south poles facing the stator 103 and their north poles coupled to the rotor 102 are positioned at opposing in-line positions near the midpoint of the rotor 102 on one side of the rotor 102 about that midpoint.

**[0041]** Similarly, the second set of magnets 105 with their north poles facing the stator 103 and their south poles coupled to the rotor 102 are positioned at opposing in-line positions on the same side of the rotor 102 at ninety degree offsets from the first set of magnets 104. An identical first set of magnets 104 and second set of magnets 105 are coupled near the midpoint of the rotor 102 at similar positions on the other side of the rotor 102 about that midpoint.

**[0042]** In Figure 2B, the structure of the longitudinally placed silicon steel laminates which comprise the stator of a high efficiency alternating current generator in accordance with an exemplary embodiment of the present invention is depicted. As shown in Figure 2B, the stator is comprised of a first steel laminate type 203 and a second steel laminate type 204. The second steel laminate type 204 contains two stator slots 111 in its lower section and a plurality of these laminates comprise those portions of the stator 103 in between where winding 106 is embedded within the stator 103. A plurality of first steel laminate type 203 laminates comprise the remaining portions of the stators 103 in which the winding 106 is embedded. The first steel laminate types 203 have a height such that the combined height of a winding 106 and a first steel laminate type 203 laminate is equal to the height of a second steel laminate type 204 laminate.

**[0043]** In Figure 3, an end cross-sectional view of a high efficiency alternating current generator according to an exemplary embodiment of the present invention is depicted. As shown in Figure 3, a single silicon steel piece 107 is positioned longitudinally in line with each magnet of the first set of magnets 104 and of the second set of magnets 105 (not shown). The position of the silicon steel pieces 107 at the ends of the rotor 102 provides for a predefined distance 109 (as shown in Figure 1) between a silicon steel piece 107 and its corresponding magnet from either the first set of magnets 104 or the second set of magnets 105.

**[0044]** In an exemplary embodiment, the distance between a silicon steel piece 107 and its corresponding magnet is equal to the longitudinal length of the corresponding magnet.

**[0045]** Referring again to Figure 1, an electromagnetic force (EMF) is created across the conductor winding 106 embedded within the stator 103 when the magnetic flux emanating from the first set of magnets 104 and from the second set of magnets 105 cuts through the conductor winding 106 embedded within the stator 103 as the rotor 102 rotates.

**[0046]** Looking in the direction of arrow C in Figure 1, with the rotor 102 turning in a clockwise direction and the magnetic flux travelling in a vertically upward direction into the south poles of the first set of magnets 104, the current generated as a result of the induced electromagnetic force will travel from right to left 110 within the conductor winding 106. This current direction follows from Fleming's Right Hand Rule.

**[0047]** The induced current within the embedded winding 107 will itself induce a magnetic field surrounding the conductors of the embedded winding 107 which will oppose the rotation that give rise to the induced current. Specifically, looking in the direction of arrow C in Figure 1, the interaction between the clockwise magnetic field surrounding the conductor as a result of the induced electromagnetic force and the downward magnetic flux into the south poles of the first pair of magnets 104 will create a counter-clockwise torque opposing the clockwise rotation of the rotor 102.

**[0048]** In Figure 4, a longitudinal cross-sectional view of the flow of magnetic fields emanating from the first set of magnets within a high efficiency alternating current generator according to an exemplary embodiment of the present invention is depicted. As shown in Figure 4, the magnetic flux 401 emanating from the north poles of the first set of magnets 104 travel vertically downward through the rotor 102, into a corresponding steel piece 107, upward across the air gap 108 and into the stator 103 as the magnetic flux 401 rotates with the rotor 102 relative to the stator 103. As this rotating magnetic flux portion 403 within the air gap 108 enters the static stator 103, it cuts sideways across the conductor winding 106 embedded within the stator 103 and induces a current within the conductor winding 106.

**[0049]** Within the stator 103, a portion of magnetic flux 402 is now trapped within the grain stampings within the stator 103 and flows longitudinally in an effort to return to a corresponding south pole of the first set of magnets 104. This portion of the magnetic flux 402 is now static relative to the stator 103 and the embedded conductor winding 106. As such, this portion of the magnetic flux 402 flows through and exits the stator 103 without any sideways movement relative to the embedded conductor winding 106 and therefore without inducing a current within the conductor winding 106.

**[0050]** The air gaps 111 within the lower portion of the stator 103 force the magnetic flux 401 to penetrate further into the stator 103 and, as such, provide for greater emersion of the magnetic flux across the conductor winding 106 embedded within the stator 103. The steel piece 107 focuses the magnetic flux portion 403 entering the air gap 108 thereby providing for a more efficient and defined path for the magnetic flux 403 entering the stator 103.

**[0051]** A portion of the magnetic flux 402 then exists the stator 103 and crosses the air gap 108 to reach the south pole of the first set of magnets 104 thereby closing the magnetic flux loop between north and south poles of each magnet within the first set of magnets 104. The positioning of the magnets 104 next to each other near the midpoint of the rotor 102 provides for equal magnetic flux flows to the right and to the left of center into the silicon steel pieces 107 on either end of the rotor.

**[0052]** In Figures 5 and 6, the interaction between the magnetic flux going into the south poles of the first set of magnets and the magnetic flux resulting from an induced current in the conductor winding of a high efficiency alternating current generator according to an exemplary embodiment of the present invention is depicted. As shown in Figures 5 and 6, the current 110 induced in the conductor winding 106 by the clockwise rotation of the rotor 102 is shown going into the page as per Fleming's Right Hand Rule. Moreover, in accordance with the application of Maxwell's corkscrew rule, the magnetic flux 501 surrounding the conductor winding 106 as a result of the induced current 110 is shown as having a clockwise rotation.

**[0053]** In Figure 5, the magnetic flux originating from the first set of magnets is shown traversing the air gap in a downward direction towards the south poles of the first set of magnets and interacting with the magnetic flux surrounding the conductor winding. The magnetic field portion 402 exiting the stator 103 is strengthened on the right side of the conductor winding 106 due to the superimposition of the magnetic field 501 induced in the conductor winding 106 in the same direction. However, the magnetic field portion 402 exiting the stator 103 is weakened on the left side of the conductor winding 106 due to the superimposition of the magnetic field 501 induced in the conductor winding 106 in the opposite direction. As a result of this interaction, the net magnetic field in the air-gap 108 over south poles of the first set of magnets 104 results in the application of a force 503 in the counter-

clockwise direction to that part portion of the conductor winding 106 within the magnetic flux portion 402 exiting the stator 103. This is in accordance with Flemings's the Left Hand rule which shows that a conductor within a downward directed magnetic field 402 and carrying a current 110 in the induced direction (going into the page) will experience the application of a force 503 in the counter-clockwise direction. The application of this counter-clockwise force 503 to the conductor winding 106 translates into a counterclockwise force 502 applied to the first set of magnets 104 which then counters the clockwise rotation of the rotor 102.

**[0054]** In Figure 6, the portion of the magnetic flux 403 that is routed through the steel pieces 107, upward across the air gap 108 and into the stator 103 is shown interacting with the induced magnetic flux surrounding the conductor winding 106. The magnetic field 403 routed up through a silicon steel piece 107 is strengthened on the leftside of the conductor winding 106 due to the superimposition of the magnetic field 501 induced in the conductor winding 106 in the same direction. However, the magnetic field 403 is weakened on the right side of the conductor winding 106 due to the superimposition of the magnetic field 501 induced in the conductor winding 106 in the opposite direction. As a result of this interaction, the net magnetic field in the air-gap 108 over the silicon steel pieces 107 results in the application of a force 603 in the clockwise direction to that part portion of the conductor winding 106 within the magnetic flux portion 403 entering the stator 103. This is in accordance with Flemings's the Left Hand rule which shows that a conductor within an upward directed magnetic field 403 and carrying a current in the induced direction (going into the page) will experience the application of a force 603 in the clockwise direction. The application of this clockwise force 603 to the conductor winding 106 translates into a clockwise force 602 applied to the silicon steel piece 107 which then supports the clockwise rotation of the rotor 102.

**[0055]** Therefore, as a result of this configuration, the conductor winding 106 embedded within the stator 103 interacts with the magnetic flux originating from the north pole of the first set of magnets 104 at two distinct position. Specifically, a first time when the magnetic field 403 enters the stator 103 in an upward direction through a silicon steel pieces 107 and a second time when the magnetic field 402 exits the stator 103 in a downward direction into the south pole of the first type of magnets 104. The net effect is that the counter-clockwise

torque on the rotor 102 generated by the magnetic field portion 402 exiting the stator 103 and returning to south pole of the first set of magnets 104 is partially canceled by the clockwise torque on the rotor 102 generated by the magnetic field portion 403 entering the stator 103 through a silicon steel piece 107. This results in a partial nullification of the back torque on the rotor 102 and results in a corresponding increase in the efficiency of the generator because the external drive source has to supply less torque to overcome the generated back torque.

**[0056]** Looking in the direction of arrow C in Figure 7, with the rotor 102 turning in a clockwise direction and the magnetic flux emanating in a vertically upward direction from the north poles of the first set of magnets 104, the current generated as a result of the induced electromagnetic force will travel from left to right 110 within the conductor winding 106. This current direction follows from Fleming's Right Hand Rule.

**[0057]** The induced current within the embedded winding 107 will itself induce a magnetic field surrounding the conductors of the embedded winding 107 which will oppose the rotation that give rise to the induced current. Specifically, looking in the direction of arrow C in Figure 1, the interaction between the counter-clockwise magnetic field surrounding the conductor as a result of the induced electromagnetic force and the downward magnetic flux into the south poles of the first pair of magnets 104 will create a counter-clockwise torque opposing the clockwise rotation of the rotor 102.

**[0058]** In Figure 7, a longitudinal cross-sectional view of the flow of magnetic fields emanating from the second set of magnets within a high efficiency alternating current generator according to an exemplary embodiment of the present invention is depicted. As shown in Figure 7, the magnetic flux 701 flowing out from the north pole of the second set of the magnets 105 travels upward across the air gap 108 and into the stator 103 as the magnetic flux 701 rotates with the rotor 102 relative to the stator 103. As this rotating magnetic flux 701 enters the static stator 103, it cuts sideways across the conductor winding 106 embedded within the stator 103 and induces a current within that conductor winding 106.

**[0059]** Within the stator 103, a magnetic flux portion 702 flows longitudinally along the grain oriented electrical steel stampings within the stator 103 from a position where the

magnetic flux portion 702 enters the stator 103. This magnetic flux portion 702 is static relative to the conductor winding 106 embedded within the stator 103. As such, this magnetic flux portion 702 enters and flows through the stator 103 without any sideways movement relative to the embedded conductor winding 106 and, therefore, without inducing a current within the conductor winding 106.

**[0060]** Outside of the stator 103, a magnetic flux portion 703 exits the stator 103, flows across the air gap 108 and into the silicon steel pieces 107. The silicon steel pieces 107 focus the magnetic flux portion 703 within the air gap 108 providing for a more efficient and specifically defined path for the magnetic flux 701 originating from a corresponding second set of magnets 105. The magnetic flux portion 703 exists the steel piece 107 and flows to the south poles of the second set of magnets 105 through the rotor 102 thereby closing the magnetic flux loop between the south and north poles of each magnet within the second set of magnets 105.

**[0061]** In Figures 8 and 9, the interaction between the magnetic flux originating from the north poles of the second set of magnets and the magnetic flux resulting from an induced current in the conductor winding of a high efficiency alternating current generator according with an exemplary embodiment of the present invention is depicted. As shown in Figures 8 and 9, the current 110 induced in the conductor winding 106 by the clockwise rotation of the rotor 102 is shown as coming out of the page in accordance with Fleming's Right Hand rule. Moreover, in accordance with the application of Maxwell's corkscrew rule, the magnetic flux 801 surrounding the conductor winding 106 as a result of the induced current 110 is shown as having a counter-clockwise rotation.

**[0062]** In Figure 8, the magnetic flux originating from the second set of magnets 105 is shown traversing the air gap in an upward direction and interacting with the magnetic flux surrounding the conductor winding 106. The magnetic field 701 originating from the second set of magnets 105 is strengthened on the right side of the conductor winding 106 due to the superimposition of the magnetic field 801 induced in the conductor winding 106 in the same direction. However, the magnetic field 701 originating from the second set of magnets 105 is weakened on the left side of the conductor winding 106 due to the superimposition of the magnetic fields 801 induced in the conductor winding 106 in the opposite direction. As a result

of this interaction, the net magnetic field in the air-gap 108 over the second set of magnets 105 results in the application of a force 803 in the counter-clockwise direction to that portion of the conductor winding 106 within the magnetic flux portion 701 entering the stator 103. This is in accordance with Fleming's Left Hand rule which shows that a conductor within an upward directed magnetic field 701 and carrying a current in the induced direction (coming out of the page) will experience the application of a force 803 in the counterclockwise direction. The application of this counterclockwise force 803 to the conductor winding 106 translates into a counterclockwise force 802 applied to the second set of magnets 105, which then opposes the clockwise rotation of the rotor 102.

**[0063]** In Figure 9, the magnetic flux portion 703 exiting the stator 103, crossing the air gap 108 and routed through the silicon steel pieces 107 is shown interacting with the induced magnetic flux 801 surrounding the conductor winding. As shown in Figure 9, the magnetic field 703 routed downwardly across the air gap 108 and into a silicon steel pieces 107 is strengthened on the left side of the conductor winding 106 due to the superimposition of the magnetic field 801 induced in the conductor winding 106 in the same direction. However, the magnetic field 703 is weakened on the right side of the conductor winding 106 due to the superimposition of the magnetic field 801 induced in the conductor winding 106 in the opposite direction. As a result of this interaction, the net magnetic field in the air-gap 108 over the silicon steel pieces 107 results in the application of a force 903 in the clockwise direction to that part portion of the conductor winding 106 within the magnetic flux portion 703 exiting the stator 103. This is in accordance with Fleming's Left Hand rule which shows that a conductor within a downward directed magnetic field 703 and carrying a current in the induced direction (coming out of the page) will experience the application of a force 903 in the counterclockwise direction. The application of this counterclockwise force 903 to the conductor winding 106 translates into a clockwise torque 902 applied to the silicon steel piece 107 which then supports the clockwise rotation of the rotor 102.

**[0064]** Therefore, as a result of this configuration, the conductor winding 106 embedded within the stator 103 interacts with the magnetic flux originating from the north pole of the second set of magnets 105 at two distinct positions. Specifically, a first time when the



magnetic field 701 enters the stator 103 in an upward direction from the north pole of the second set of magnets 105 and a second time when the magnetic field portion 703 exits the stator 103 in a downward direction into a silicon steel piece 107. The net effect is that the counter-clockwise torque on the rotor 102 generated by the magnetic field portion 701 entering the stator 103 from the north pole of the second set of magnets 105 is partially canceled by the clockwise torque on the rotor 102 generated by the magnetic field portion 703 exiting the stator 103 into a silicon steel piece 107. This results in a partial nullification of the back torque on the rotor 102 and results in a corresponding increase in the efficiency of the generator because the external drive source has to supply less torque to overcome the generated back torque.

## CLAIMS

What is claimed:

1. A high efficiency alternating current generator, comprising:

a hollow stator core having an axis comprised of laminated sheets of high permeability magnetic steel positioned longitudinally, the laminated sheets including longitudinally embedded slots in which a conductor winding is laid parallel to the axis;

a cylindrical rotor concentric with and positioned inside the hollow stator core comprised of a high permeability magnetic material;

a shaft coupled to the rotor and driven by an external source so as to freely rotate the rotor relative to the hollow stator core;

a first set of magnets in which the south pole of each magnet is coupled to the surface to the rotor and the north pole of each magnet is facing the inner surface of the hollow stator core;

a second set of magnets in which the north pole of each magnet is coupled to the surface of the rotor and the south pole of each magnet is facing the inner surface of the hollow stator core; and

a set of silicon steel pieces coupled to the outer surface of the rotor comprised of individual silicon steel pieces positioned adjacent to and longitudinally in line with each individual magnet within the first set of magnets and each individual magnet within the second set of magnets.

2. The high efficiency alternating current generator of claim 1, wherein each silicon steel piece is positioned relative to a corresponding magnet to create magnetic a circuit through the silicon steel piece and the corresponding magnet such that the magnetic flux emanating from

each magnet is guided in one direction into the stator and then guided in an opposite direction out of the stator.

3. The high efficiency alternating current generator of claim 1, wherein the silicon steel pieces are sized to have approximately the same surface area as the corresponding magnets.

4. The high efficiency alternating current generator of claim 1, wherein the silicon steel pieces are positioned to provide for a return path for the magnetic field into the rotor.

5. The high efficiency alternating current generator of claim 1, wherein the first set of magnets and the second set of magnets can be permanent magnets.

6. The high efficiency alternating current generator of claim 5, wherein the permanent magnets can be Neodymium, Samarian Cobalt or Ceramic.

7. The high efficiency alternating current generator of claim 1, wherein the first set of magnets and the second set of magnets are electromagnets.

8. The high efficiency alternating current generator of claim 1, wherein the electromagnets are comprised of steel alloy having a high flux density of saturation.

9. The high efficiency alternating current generator of claim 1, wherein the high permeability magnetic laminations which make up the stator are made from grain oriented electrical steel, the grains oriented as to facilitate the flow of magnetic flux between a magnet and a corresponding silicon steel piece.

10. The high efficiency alternating current generator of claim 1, wherein the stator includes stator slots running axially for 360 degrees within the stator and positioned at points in between the steel pieces and the first set if magnets the second set of magnets.

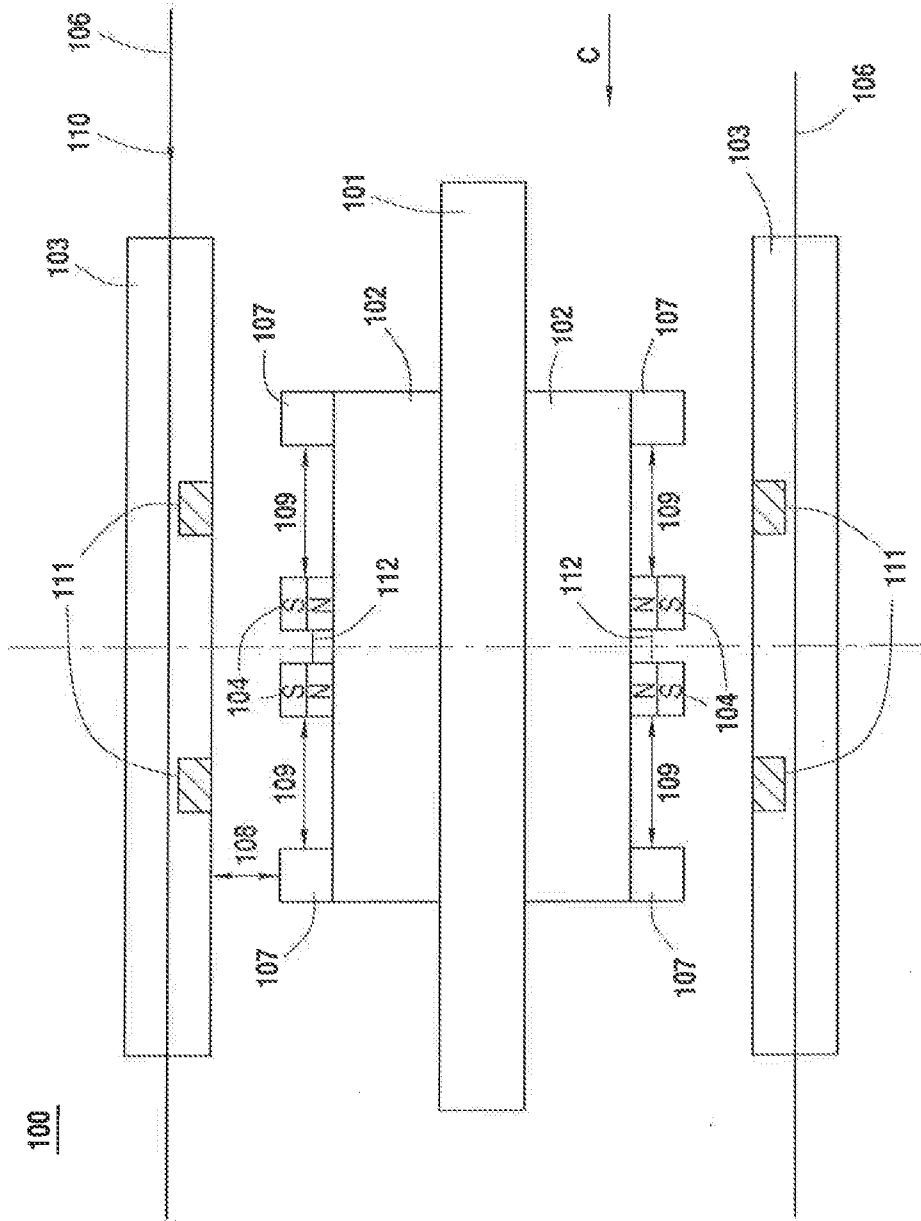

FIG. 1

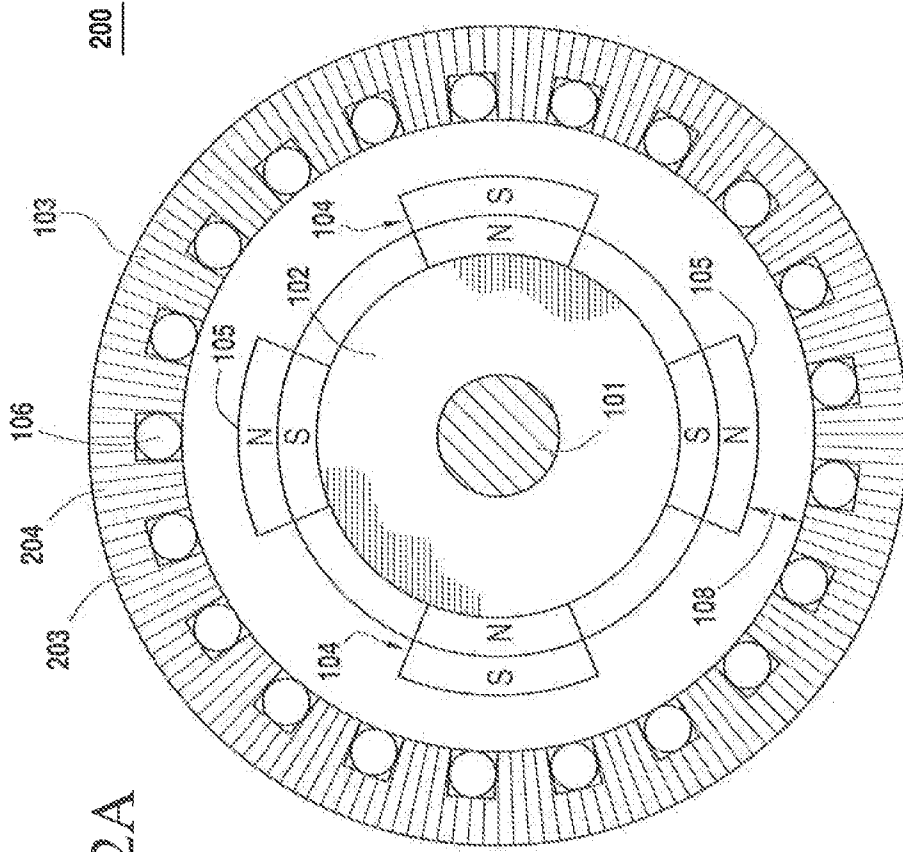

FIG. 2A

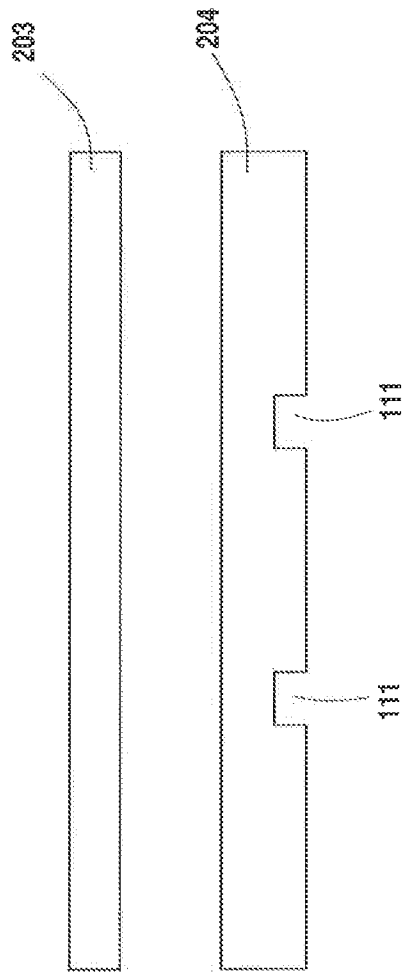

FIG. 2B

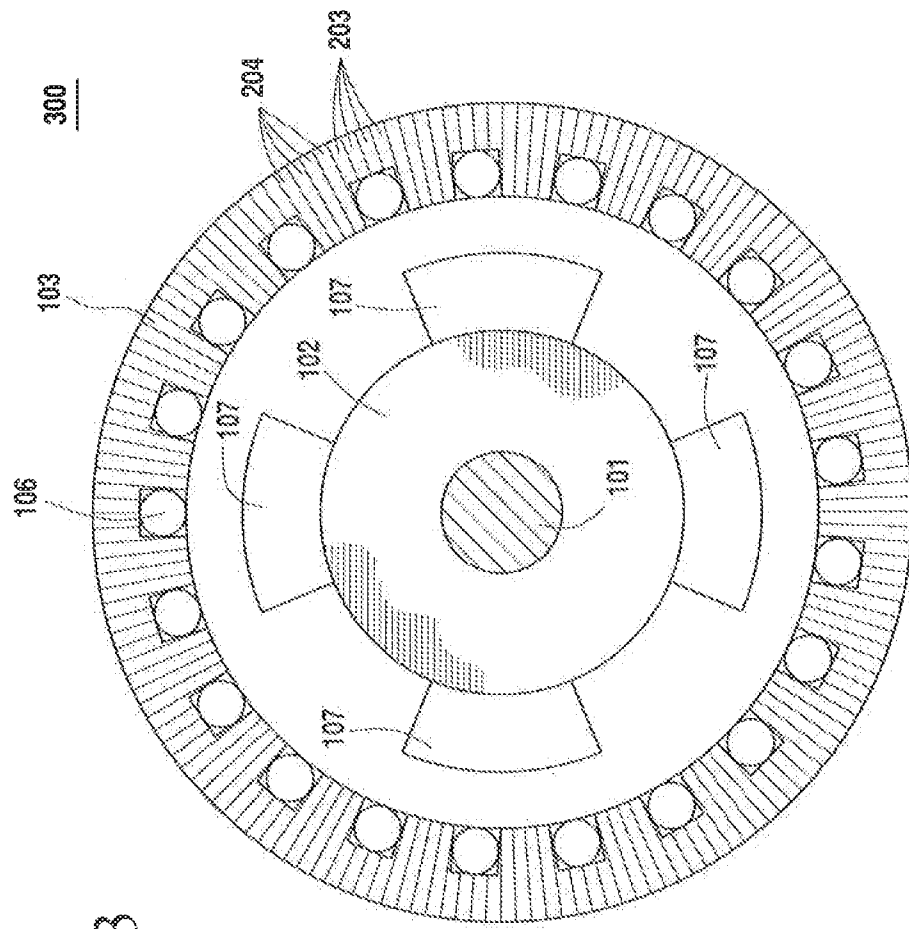

FIG. 3

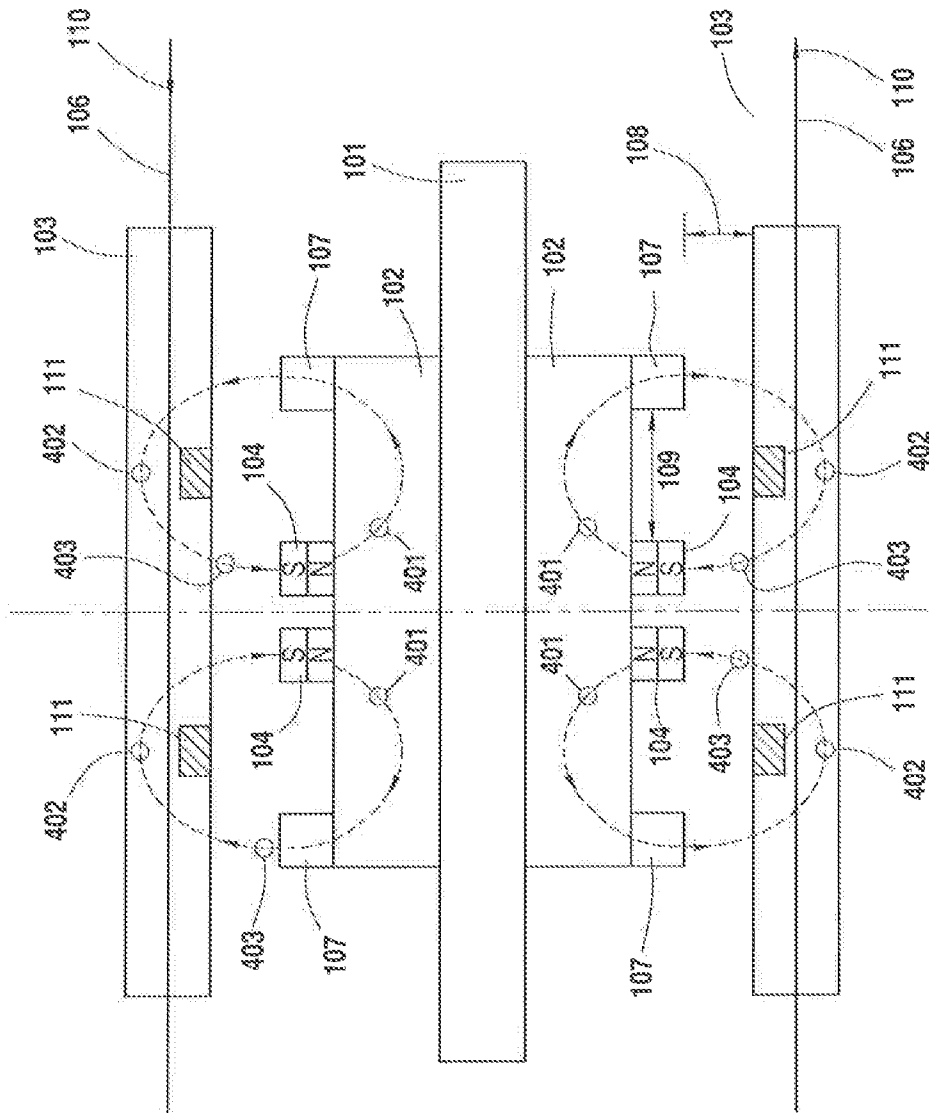

FIG. 4



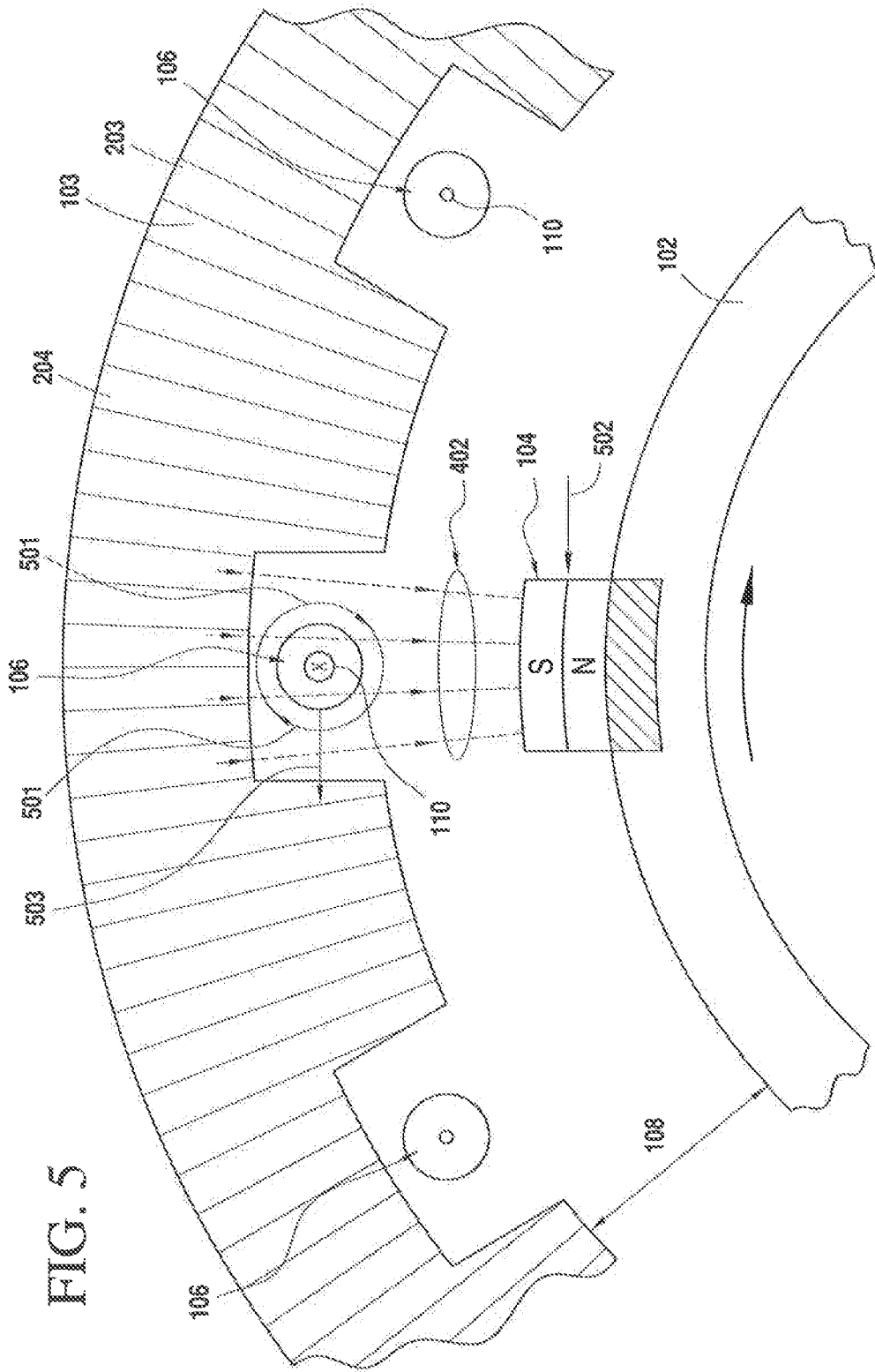
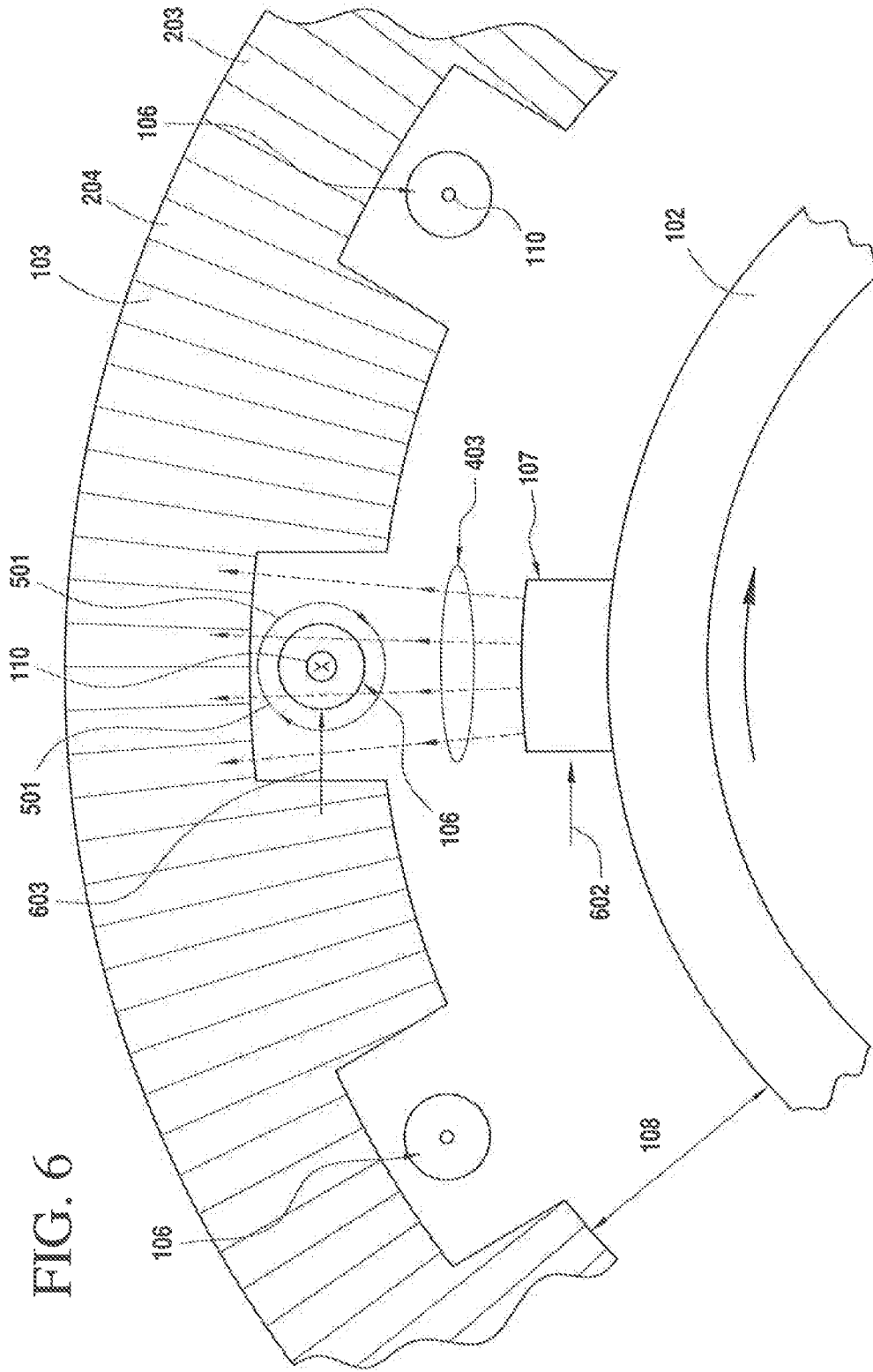

FIG. 5

FIG. 6



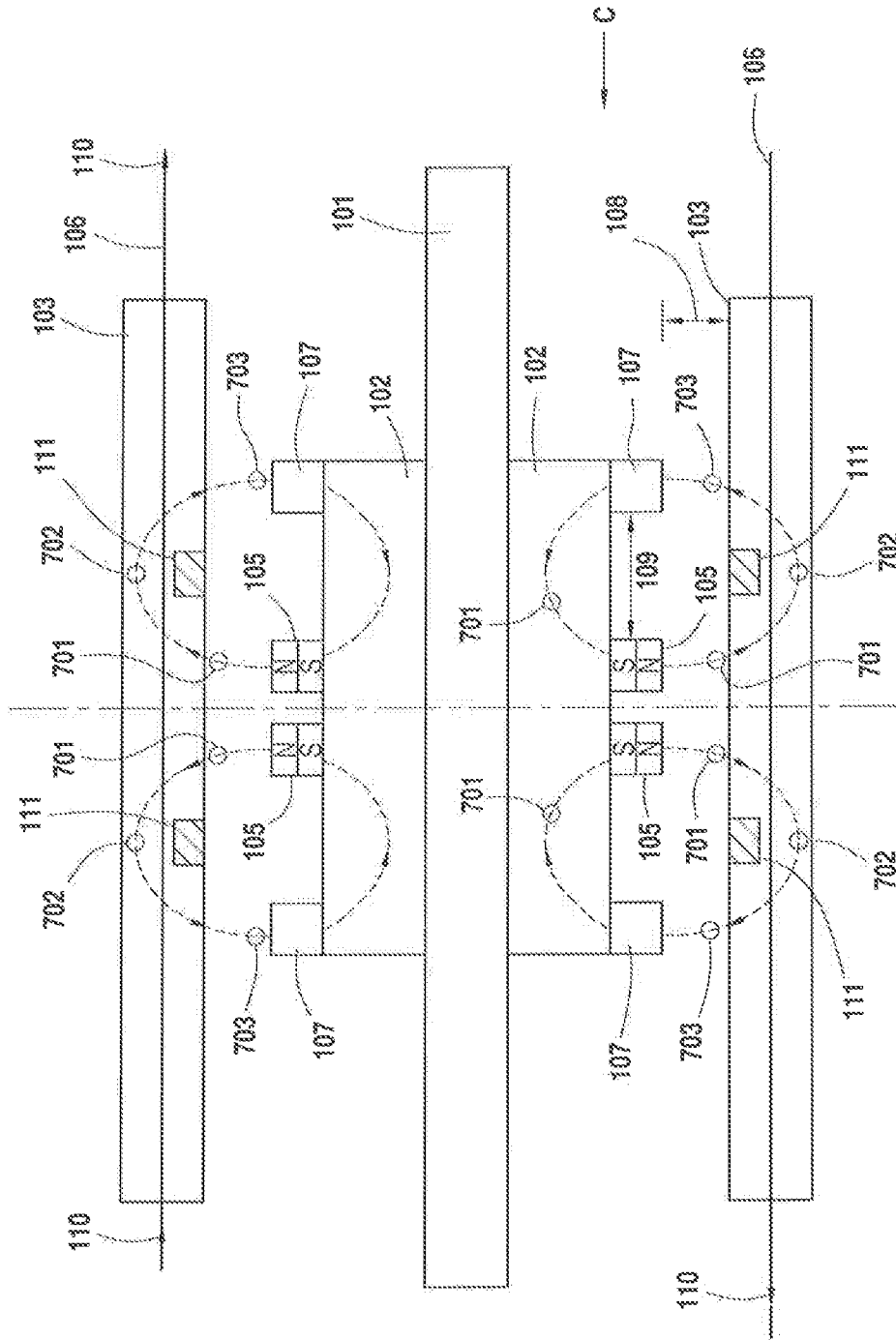

FIG. 7

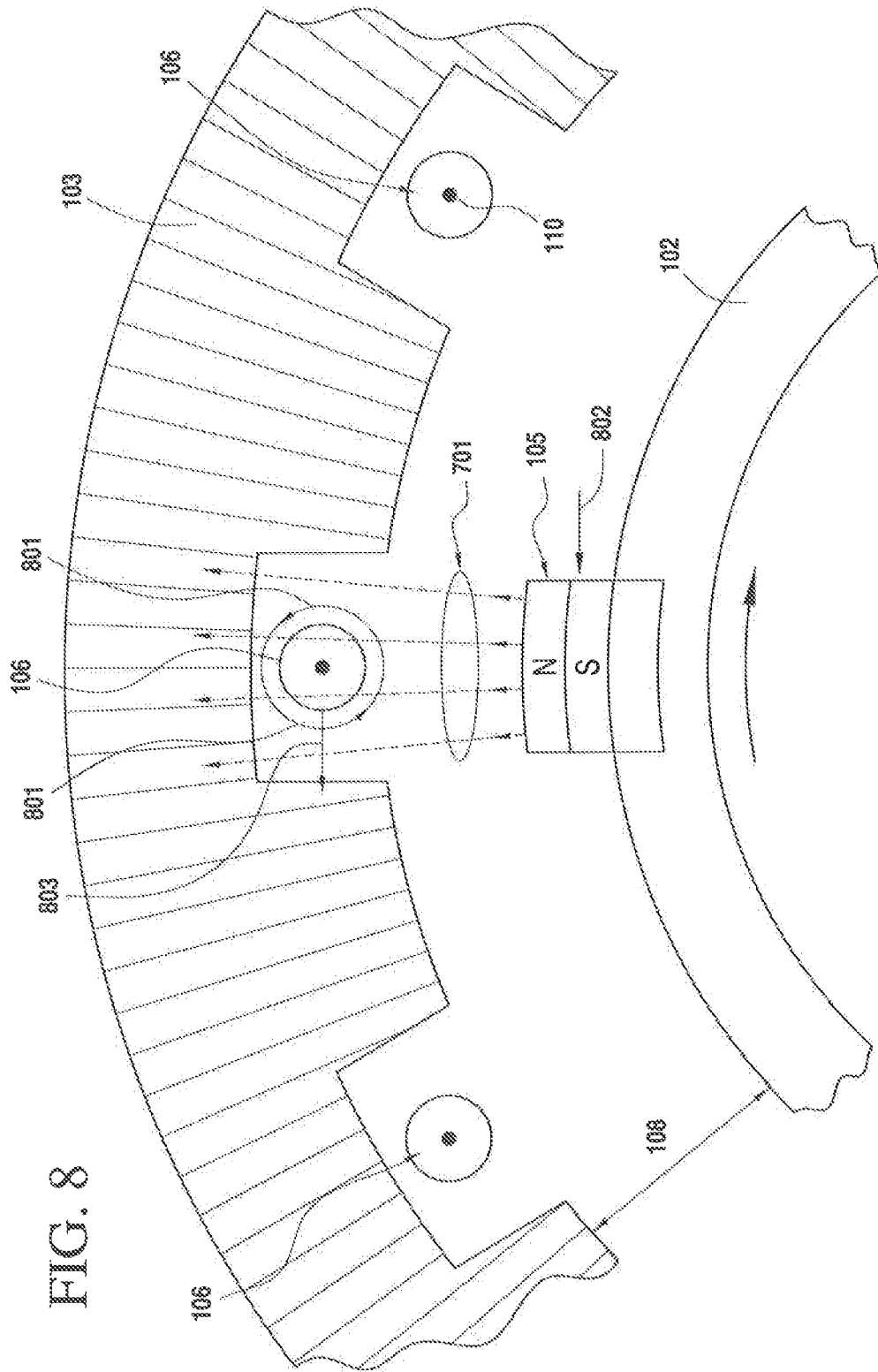

FIG. 8

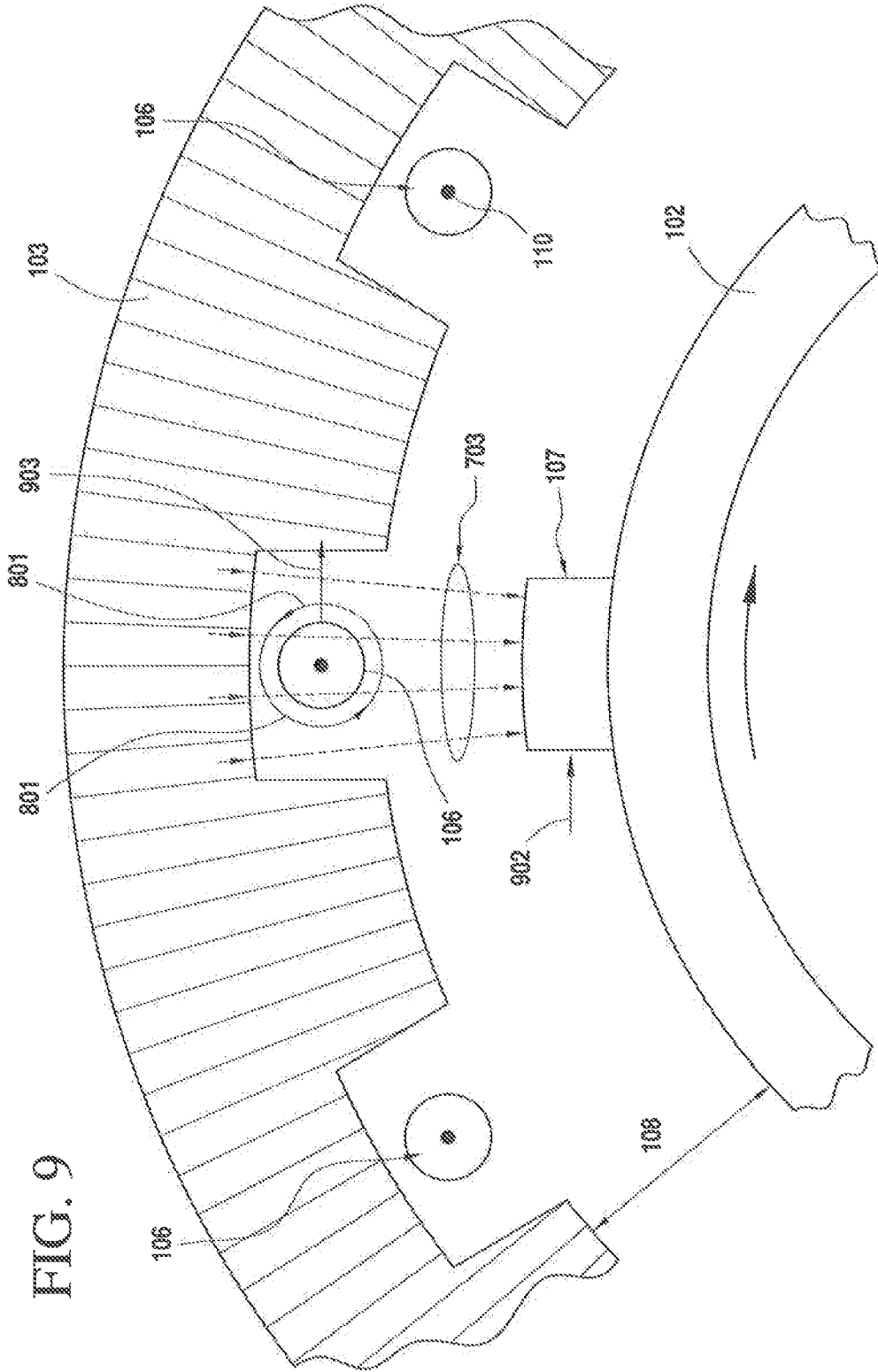

FIG. 9

## INTERNATIONAL SEARCH REPORT

International application No.

PCT/IB 15/01437

<p>A. CLASSIFICATION OF SUBJECT MATTER          IPC(8) - H02K 1/27 (2016.01)          CPC - H02K 21/14, H02K 1/272          According to International Patent Classification (IPC) or to both national classification and IPC</p>												
<p>B. FIELDS SEARCHED</p> <p>Minimum documentation searched (classification system followed by classification symbols)          IPC(8) - H02K 1/27 (2016.01)          CPC - H02K 21/14, H02K 1/272</p> <p>Documentation searched other than minimum documentation to the extent that such documents are included in the fields searched          IPC(8) - H02K 1/27 (2016.01)          CPC - H02K 21/14, H02K 1/272; USPC - 310/156.43</p> <p>Electronic data base consulted during the international search (name of data base and, where practicable, search terms used)          Patbase; Google Web, Google Patent          Search terms used, <del>ye</del> motor machine rotor stator silicon steel block piece section slab sets alternating magnets laminations          silicon hysteresis permeability</p>												
<p>C. DOCUMENTS CONSIDERED TO BE RELEVANT</p> <table border="1"> <thead> <tr> <th>Category*</th> <th>Citation of document, with indication, where appropriate, of the relevant passages</th> <th>Relevant to claim No.</th> </tr> </thead> <tbody> <tr> <td>X</td> <td>US 2015/0084467 A1 (PARAMAHAMSA) vβ March 2015 (26.03.2016), para [0014], [0047], [0030H0037]; claim 1, 6-9; Fig 3</td> <td>1-10</td> </tr> <tr> <td>A</td> <td>US 2005/0242679 A1 (WALTER et al.) 03 November 2005 (03.11.2005), entire document</td> <td>1-10</td> </tr> </tbody> </table>			Category*	Citation of document, with indication, where appropriate, of the relevant passages	Relevant to claim No.	X	US 2015/0084467 A1 (PARAMAHAMSA) vβ March 2015 (26.03.2016), para [0014], [0047], [0030H0037]; claim 1, 6-9; Fig 3	1-10	A	US 2005/0242679 A1 (WALTER et al.) 03 November 2005 (03.11.2005), entire document	1-10	
Category*	Citation of document, with indication, where appropriate, of the relevant passages	Relevant to claim No.										
X	US 2015/0084467 A1 (PARAMAHAMSA) vβ March 2015 (26.03.2016), para [0014], [0047], [0030H0037]; claim 1, 6-9; Fig 3	1-10										
A	US 2005/0242679 A1 (WALTER et al.) 03 November 2005 (03.11.2005), entire document	1-10										
<input type="checkbox"/> Further documents are listed in the continuation of Box C. <input type="checkbox"/>												
<p>* Special categories of cited documents:</p> <table border="0"> <tr> <td>"A" document defining the general state of the art which is not considered to be of particular relevance</td> <td>T later document published after the international filing date or priority date and not in conflict with the application but cited to understand the principle or theory underlying the invention</td> </tr> <tr> <td>"E" earlier application or patent but published on or after the international filing date</td> <td>"X" document of particular relevance; the claimed invention cannot be considered novel or cannot be considered to involve an inventive step when the document is taken alone</td> </tr> <tr> <td>"L" document which may throw doubts on priority claim(s) or which is cited to establish the publication date of another citation or other special reason (as specified)</td> <td>"Y" document of particular relevance; the claimed invention cannot be considered to involve an inventive step when the document is combined with one or more other such documents, such combination being obvious to a person skilled in the art</td> </tr> <tr> <td>"O" document referring to an oral disclosure, use, exhibition or other means</td> <td>"&amp;" document member of the same patent family</td> </tr> <tr> <td>"P" document published prior to the international filing date but later than the priority date claimed</td> <td></td> </tr> </table>			"A" document defining the general state of the art which is not considered to be of particular relevance	T later document published after the international filing date or priority date and not in conflict with the application but cited to understand the principle or theory underlying the invention	"E" earlier application or patent but published on or after the international filing date	"X" document of particular relevance; the claimed invention cannot be considered novel or cannot be considered to involve an inventive step when the document is taken alone	"L" document which may throw doubts on priority claim(s) or which is cited to establish the publication date of another citation or other special reason (as specified)	"Y" document of particular relevance; the claimed invention cannot be considered to involve an inventive step when the document is combined with one or more other such documents, such combination being obvious to a person skilled in the art	"O" document referring to an oral disclosure, use, exhibition or other means	"&" document member of the same patent family	"P" document published prior to the international filing date but later than the priority date claimed	
"A" document defining the general state of the art which is not considered to be of particular relevance	T later document published after the international filing date or priority date and not in conflict with the application but cited to understand the principle or theory underlying the invention											
"E" earlier application or patent but published on or after the international filing date	"X" document of particular relevance; the claimed invention cannot be considered novel or cannot be considered to involve an inventive step when the document is taken alone											
"L" document which may throw doubts on priority claim(s) or which is cited to establish the publication date of another citation or other special reason (as specified)	"Y" document of particular relevance; the claimed invention cannot be considered to involve an inventive step when the document is combined with one or more other such documents, such combination being obvious to a person skilled in the art											
"O" document referring to an oral disclosure, use, exhibition or other means	"&" document member of the same patent family											
"P" document published prior to the international filing date but later than the priority date claimed												
<p>Date of the actual completion of the international search</p> <p>01 February 2016 (01.02.2016)</p>		<p>Date of mailing of the international search report</p> <p><b>12 FEB 2016</b></p>										
<p>Name and mailing address of the ISA/US</p> <p>Mail Stop PCT, Attn: ISA/US, Commissioner for Patents          P.O. Box 1450, Alexandria, Virginia 22313-1450          Facsimile No. 571-273-8300</p>		<p>Authorized officer;</p> <p>Lee W. Young</p> <p>PCT Helpdesk: 571-272-4300          PCT OSP: 571-272-7774</p>										