

Selfrunning Free Energy Muller Motor Generator from User RomeroUK powering a 20 Watts bulb

Edited by Stefan Hartmann for <http://www.overunity.com/index.php?topic=3842>

Here are the 2 original video:
Muller type generator with extra magnets

<http://www.youtube.com/watch?v=nnO9O-fm9TU>

and

Muller Generator - self running - Test1

http://www.youtube.com/watch?v=dDW_OfkIaIU

Backup copies:

<http://www.youtube.com/watch?v=8KVU3ZM14rw>

<http://www.youtube.com/watch?v=o3YqCp84IOE>

Sideview of the rotor disc with 8 magnets (only 1 shown) and 1 coil pair shown on stator
(Stator has a total of 9 coil pairs(7 pickup coilpairs and 2 drive coilpairs))

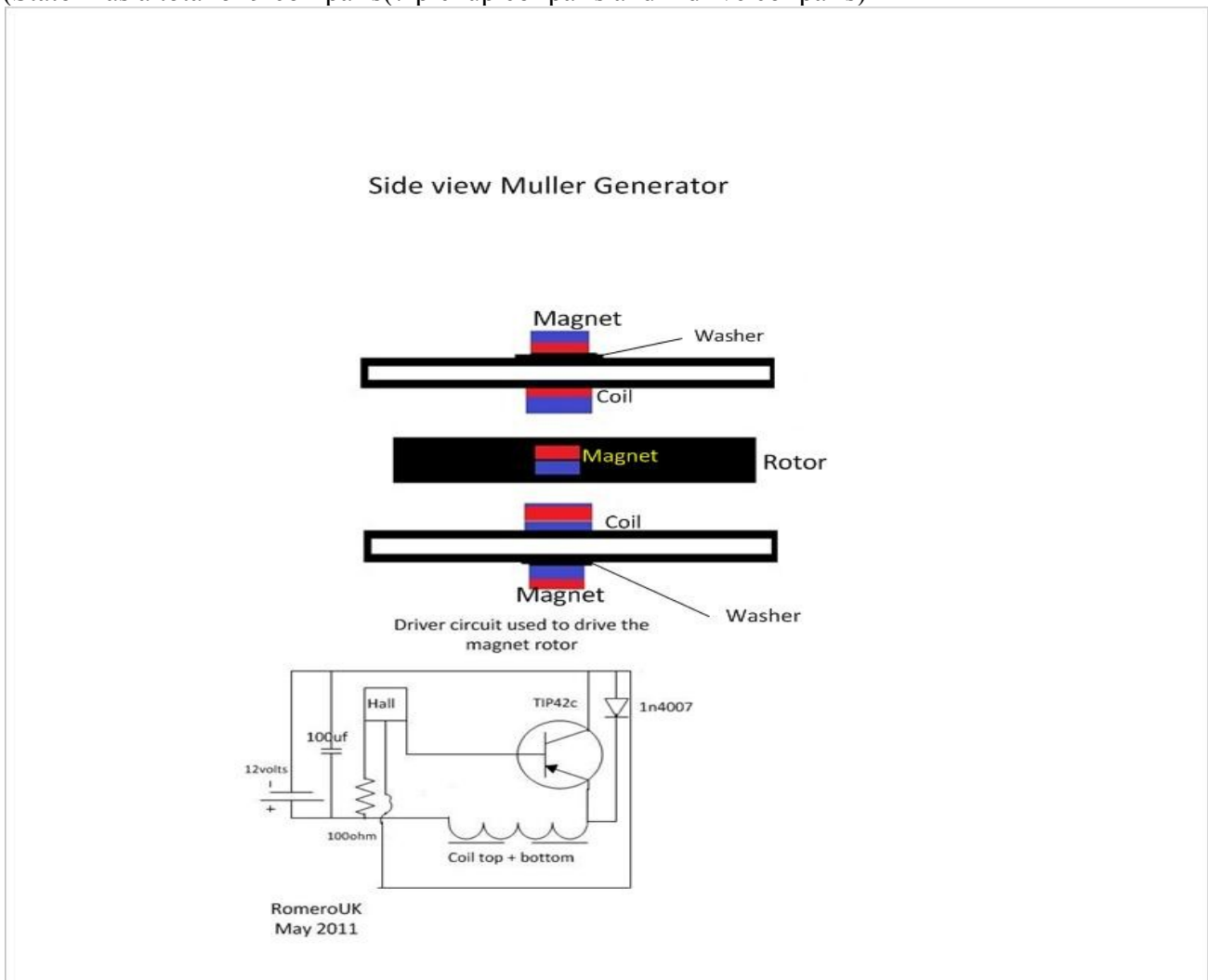

Only 2 coils (pairs) are driving.

All other coils are connected to bridge rectifiers, each set of coils goes to a rectifier then all are connected in parallel not in series as someone said before.

Each coil has 300 turns of 0.8mm multistrand, one set of coils is 600 turns in total.

The core is ferrite 6mm diameter 15mm long.

before spending lots of money and time try to replicate my old example from the following link

<http://www.youtube.com/watch?v=9IYTr16vdOM>

Use any number of magnets but make sure that at anyone time you have a magnet in position to compensate the drag created by the coil.

use a motor to drive the rotor and make sure you start testing with a load connected then adjust the magnet up and down to eliminate the drag as much is possible and get best output. More easier than this is not possible and I have posted that info long time back.

Please keep me updated with your progress.

This is a overview of the setup:

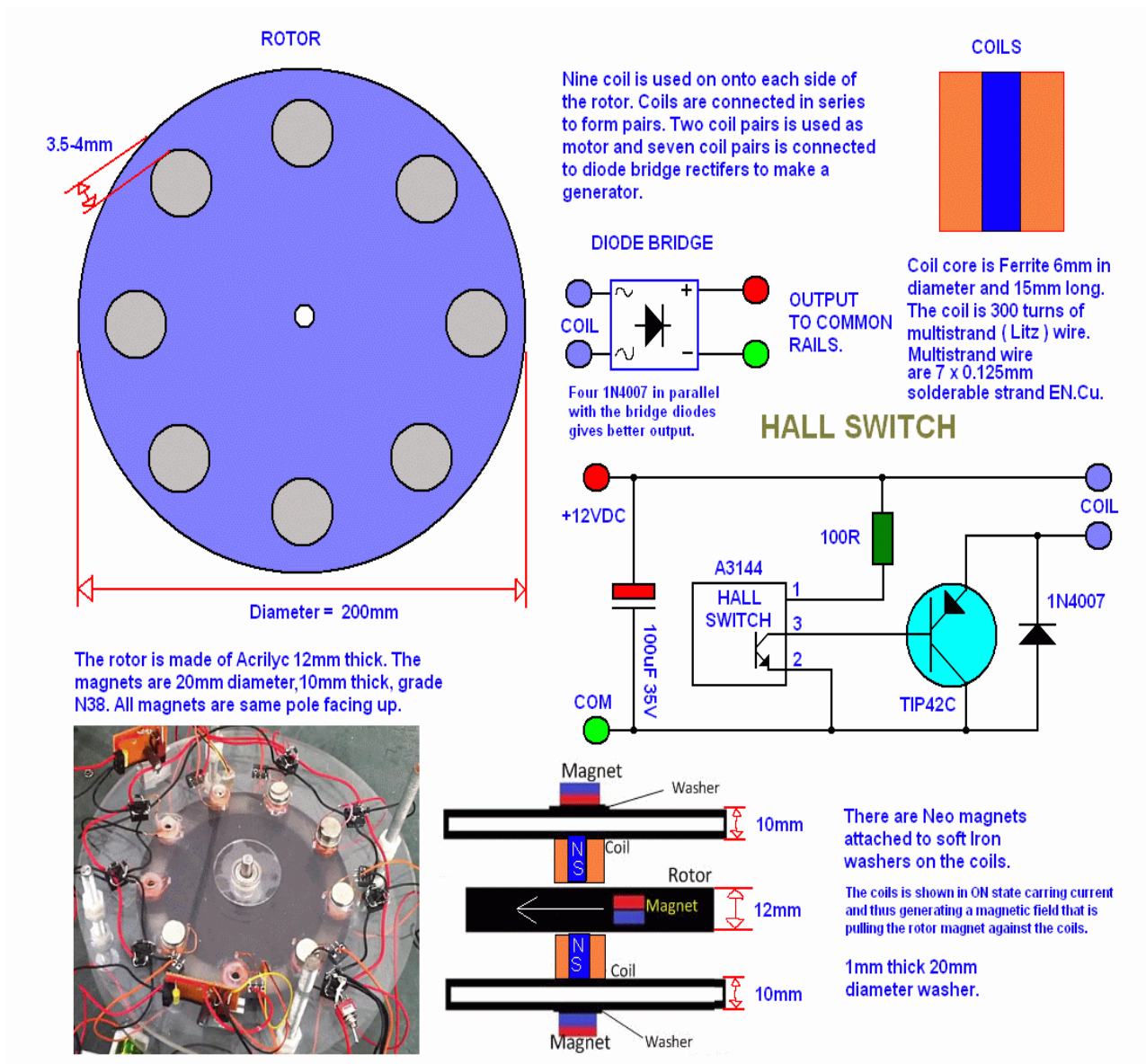

Here is the complete wiring diagram:

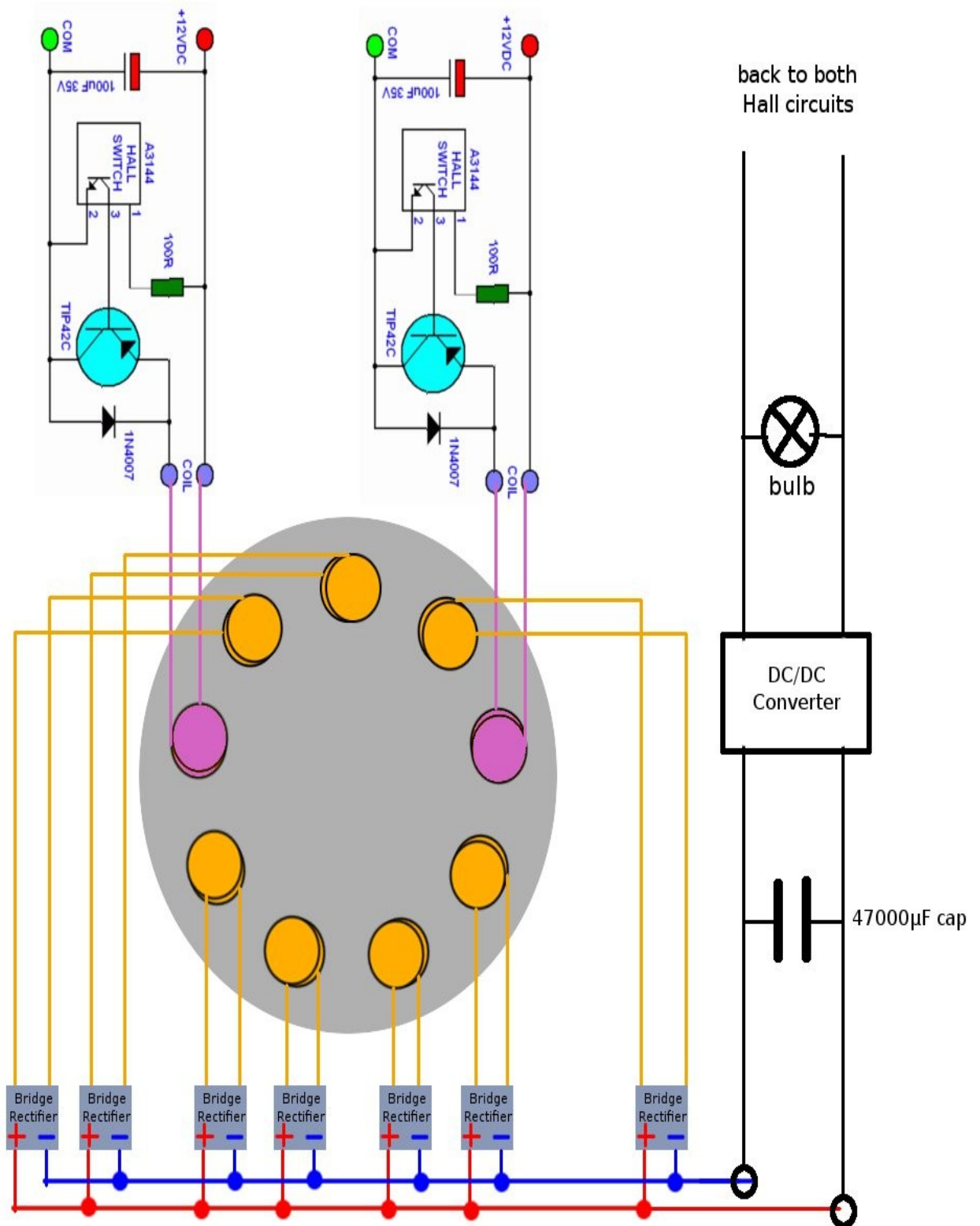

And here is the looping setup:

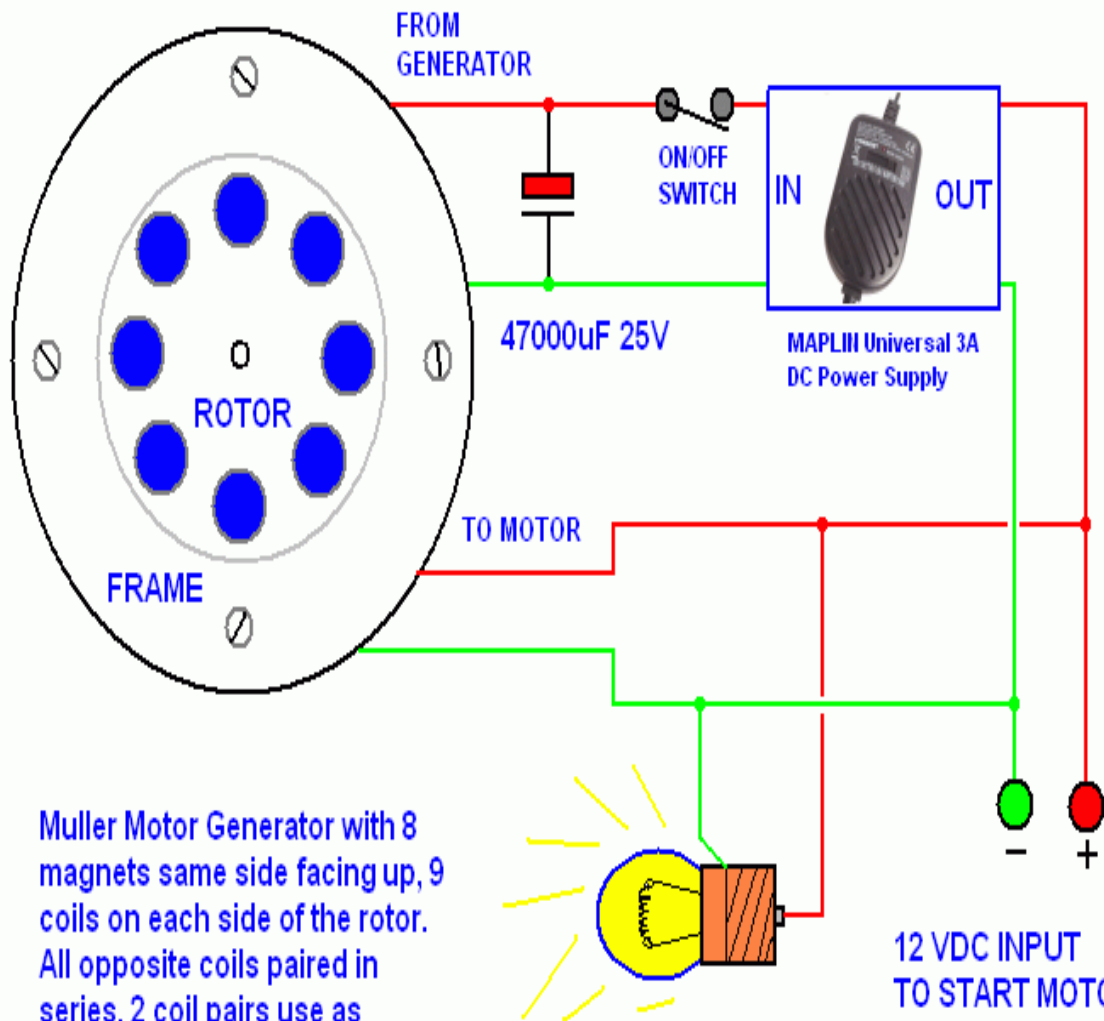

Muller Motor Generator with 8 magnets same side facing up, 9 coils on each side of the rotor. All opposite coils paired in series. 2 coil pairs use as motor. 7 coil pairs used as generator.

Note: Diode bridges and motor switches is integrated onto the Motor Generator and not shown in this drawing.

LIGHT BULB
12 VOLT 20 WATT

12 VDC INPUT
TO START MOTOR.

DISCONNECT AFTER
STARTING MOTOR.

This is the driver circuit for the 2 driver coilpairs:

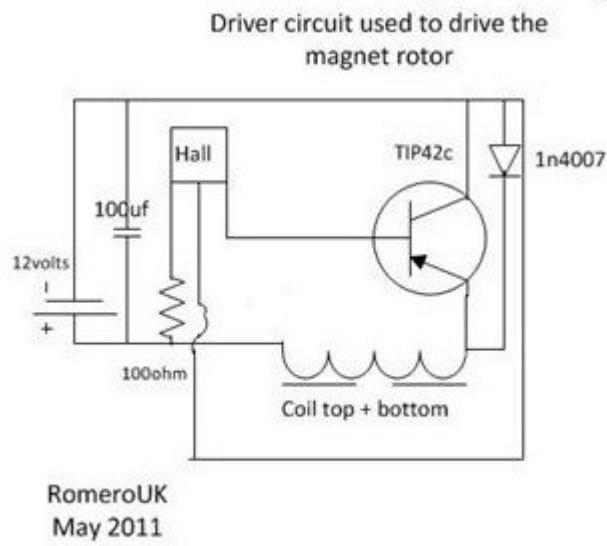

This is the setup of all the coil pairs (7 pickup coilpairs and 2 driver coilpairs)

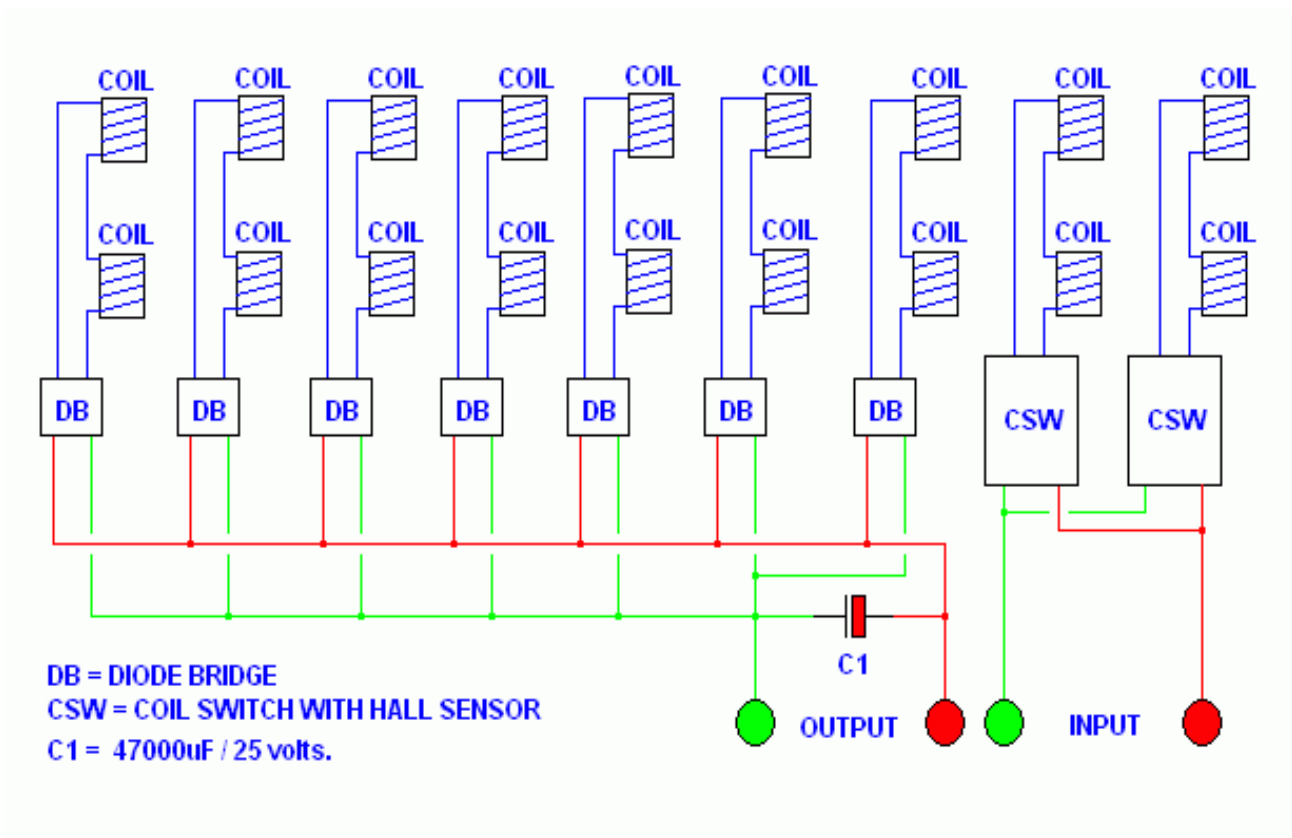

This is the enhanced bridge rectifier with additional 4 x 1N4007 diodes for more output

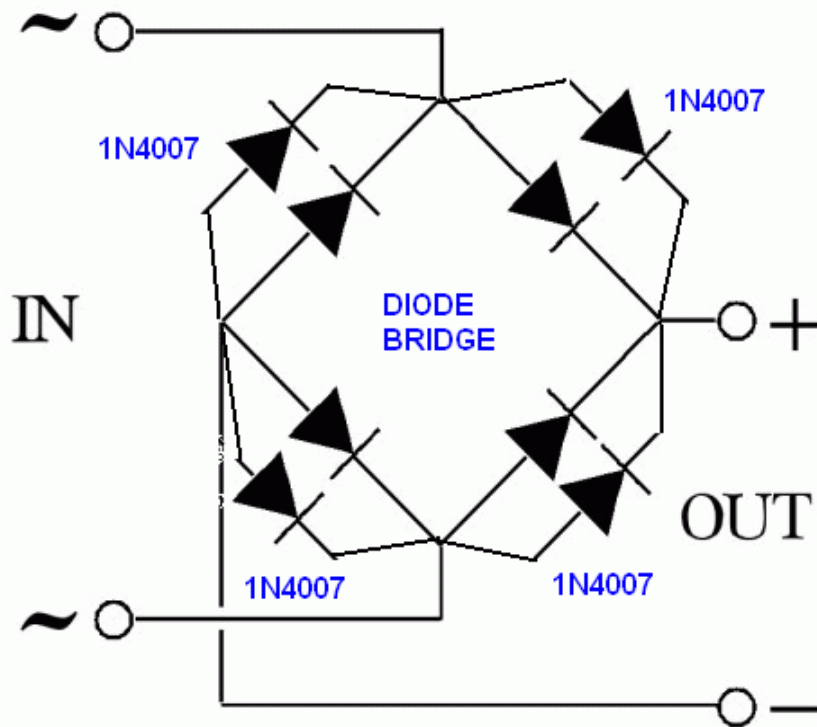
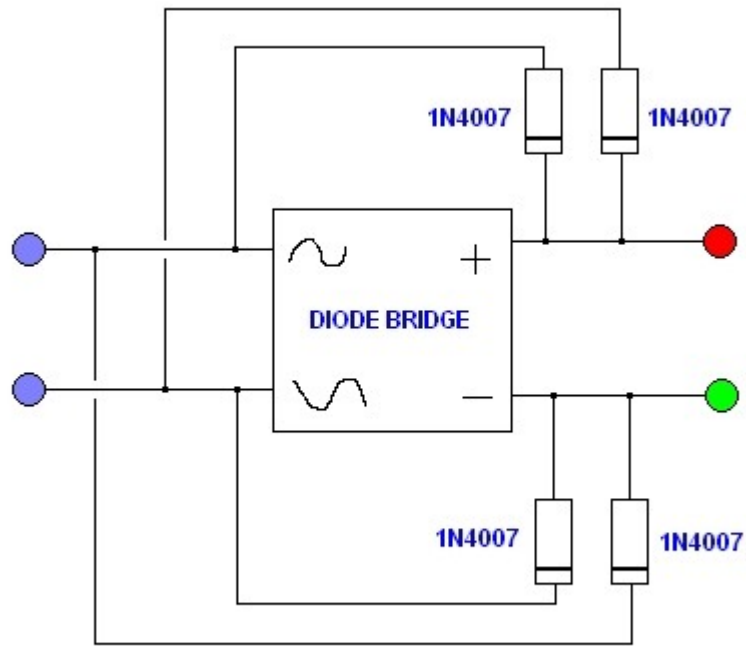

This is the sideview of the black rotor disc with 8 small additional magnets for the hall sensor triggering.

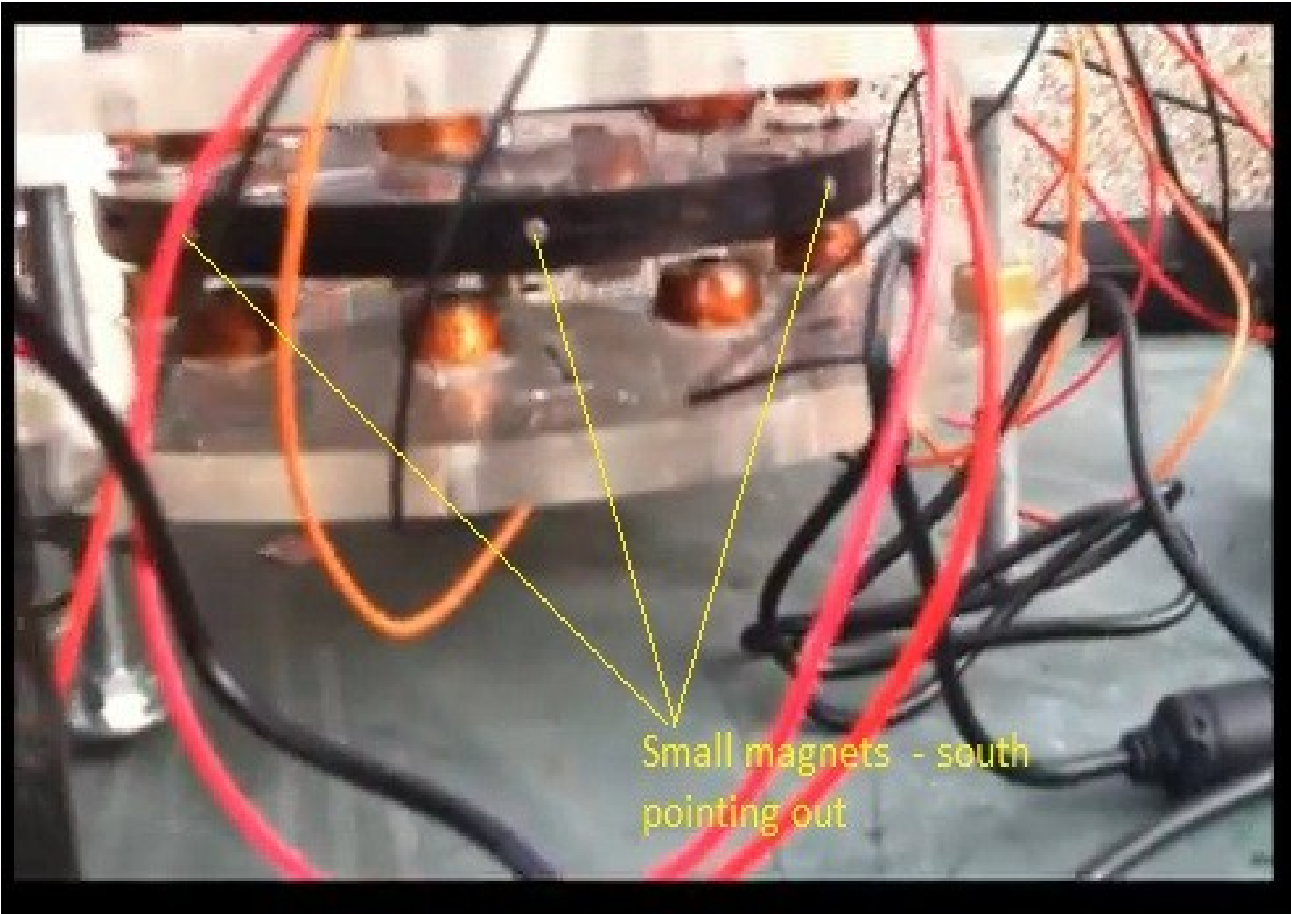

This is the setup of the rotor disc with its 8 holes for the rotor magnets:

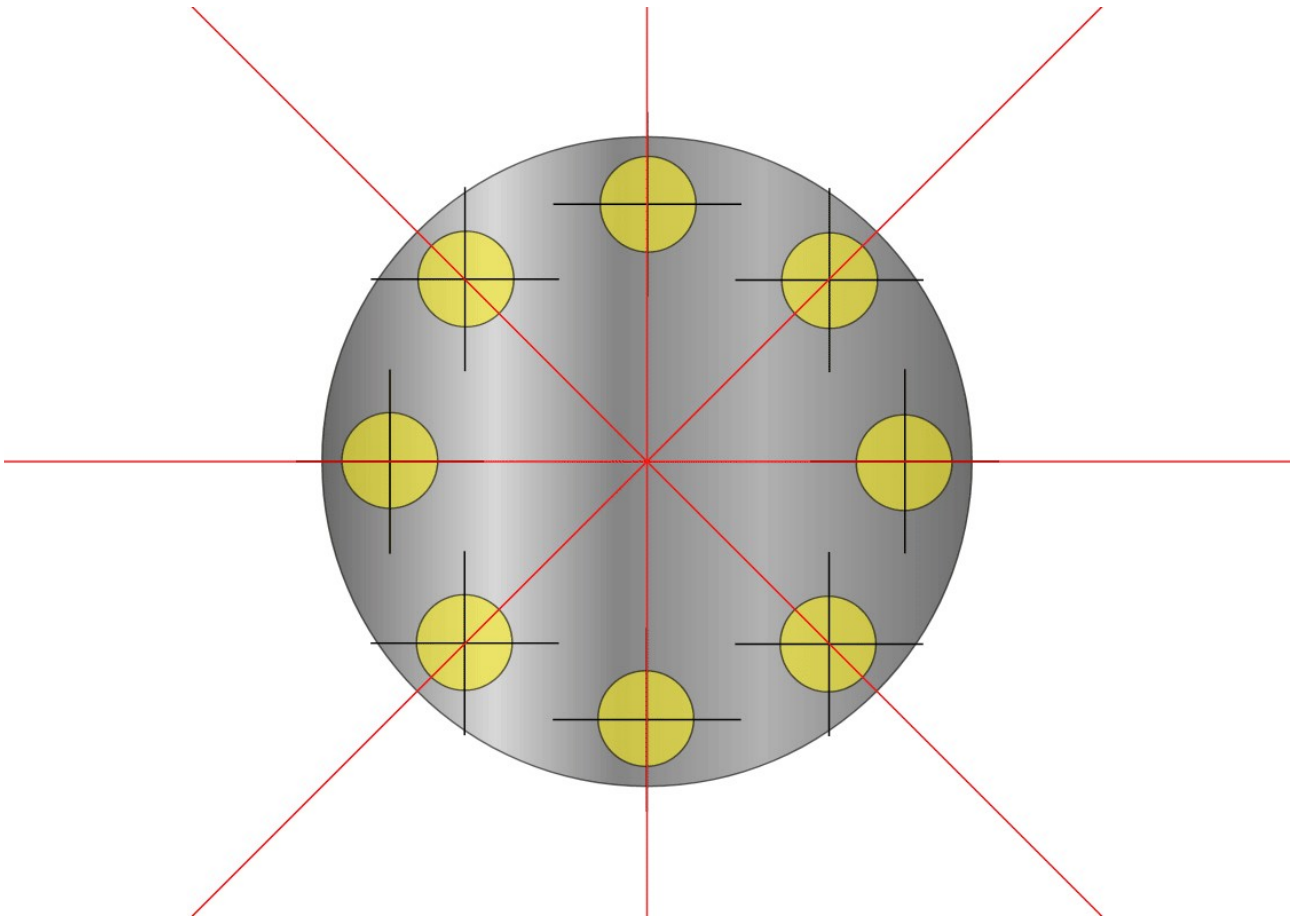

This is the top view of the stator plate with its 9 green holes for the coil pairs.
(Beneath is seen the rotor disc in grey color with the 8 rotor magnet holes)

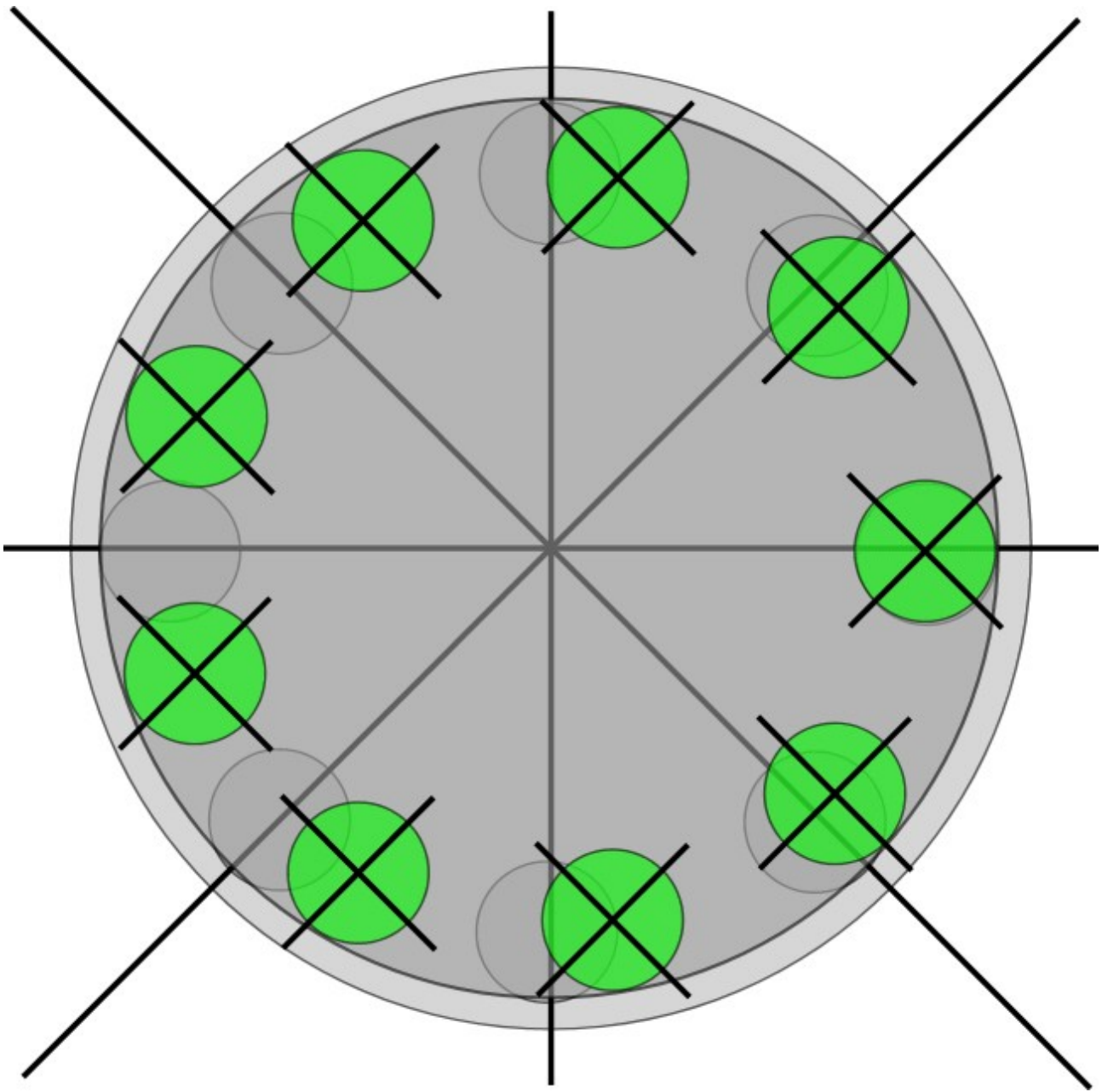

Here is shown the substitution hall circuit for the triggering circuit:



US5781 Unipolar Hall Switch – Medium Sensitivity

Features and Benefits

- Wide operating voltage range from 3.5V to 24V
- Medium sensitivity
- CMOS technology
- Chopper-stabilized amplifier stage
- Low current consumption
- Open drain output
- Thin SOT23 3L and flat TO-92 3L both RoHS Compliant packages

Application Examples

- Automotive, Consumer and Industrial
- Solid-state switch
- Interrupter
- Current detector
- Proximity detection

Ordering Information

Part No.	Temperature Code	Package Code
US5781	E (-40°C to 85°C)	SE (TSOT-3L)
US5781	E (-40°C to 85°C)	UA (TO-92)
US5781	L (-40°C to 150°C)	SE (TSOT-3L)
US5781	L (-40°C to 150°C)	UA (TO-92)

1 Functional Diagram

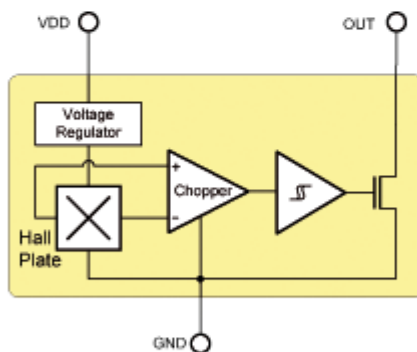

2 General Description

The Melexis US5781 is a unipolar Hall-effect switch designed in mixed signal CMOS technology.

The device integrates a voltage regulator, Hall sensor with dynamic offset cancellation system, Schmitt trigger and an open-drain output driver, all in a single package.

Thanks to its wide operating voltage range and extended choice of temperature range, it is suitable for use in automotive and solid state switch applications.

The device is delivered in a Thin Small Outline Transistor (TSOT) for surface mount process and in a Plastic Single In Line (TO-92 flat) for through-hole mount. Both 3-lead packages are RoHS compliant.

Notes from RomeroUK:

I am not sure exactly about the weight but is about 2kg with the magnets on.

The rotor is made of Acrylic 1.2cm thick. No smoothing in the video shown but yesterday I have added a capacitor to the load and I've got better results.

I had it running for days without losing the charge. I have even started from 8volts in the battery and that charged and was running ok. No need to change batteries, I will try to have it running without battery just capacitors, today I will have the answer... I must get that dc/dc converter first. Even looping back I should still be able to lit a 5w bulb at the same time.

I have used a 4700uf/25v and the voltage increased to 13.8 with the load

The magnets are 2cm diameter with 1cm thick, not very sure about the grade, I think are N38, I have bought them long time ago.

The reason to use multistrand is that most of my devices I built I used multistrand.

Some tests from other projects before showed me that using multistrand wire I get better results.

Another reason is the type of wire I had when I started the project and also much easier to build the coils when the wire is more flexible. I think there are 7 wires in (I am not home now to check).

The ferrite rods are recovered from computer PSU, used as filters with copper wire on them. I do work with computers and all PSU I need to replace I get the goodies out before disposal, free source for many useful components.

The battery is 17 amp but it is about 5 years old, not very good but still works.

Regarding changing the driving coils... I prefer to keep it as is, I am happy enough with the results, no need to prove anything, I know it works. I started this project not to get super power but to see how it works and if it works, so far results are good enough. I bought a DC/DC converter today and this evening I will try self looping...

Something similar with my setup but a bigger scale

<http://www.youtube.com/user/NewSpaceTechnology#p/u/0/JdCSbLdKVJw>

"Perpetual motion is stored in the magnets.

The Magnets ARE the Motor."

"By cleverly counter-balancing their equal and opposite reactions to each other, in space and in time, partly by mechanics, partly by timing, partly by circuitry, and partly by material science, Mechanical / Electrical work can be extracted from them sufficient to show so-called Over-Unity production of Net Energy."

"That means, efficiency greater than 100%,
an actual amplification of the available energy
as opposed to a net consumption of the energy."

..... Bill Muller

I understand now. I know there is a lot of improvement that can be done on driving circuit. I used something I tested and used many times before. Any driver circuit will do, even simple bedini if the driving coils are made that way.

The 'helper magnet' is separated from the coil by the thickness of the acrylic (1cm). On the acrylic is glued a 1mm/20mm washer then the magnet on top.

I am driving in attraction mode. I have started the project in repulsion then tried attraction. I get much better torque in attraction.

I have spent about one month to do all this testings and adjustments. Small things can make a huge difference, like my extra diodes on top of the rectifier. The gap from the rotor to the coil I had it increased and decreased hundreds of times to get it right.

All the best,
RomeroUK

What is the diameter of you rotor?

Also, what is the distance from the rotor outer rim and to the Neo magnets?

GL.

Sorry, diameter is 25cm and distance from the rotor to the coils is about 3.5-4mm.

Well you saw something but not quite right. The 2 driver coils are using multistrand from the monitor deflection coils, all others are from the folowing link:

http://wires.co.uk/acatalog/st_wire.html
7 X 0.125MM SOLDERABLE STRAND EN.Cu 500g
Ref: ST01250007-500

The capacitor u see in the video is connected before the DC/DC regulator, direct to the bridge rectifier. I had one at the output but it does not make any difference with the regulator in place

@romerouk,

What was the uF value and voltage rating of you BIG electrolytic capacitor?

GL.

The capacitor used is 47000uf/25volts.

I just had it started manually, no battery.

I turned the rotor few times with my hand to get some charge to the capacitor then switched the converter on. It started ok, no problem. The advantage here is that the circuit starts working from about 3.5 volts.

The on/off switch is before the converter just after the 47000uf capacitor. If I start with the converter on it is more difficult.

We can have a switch at the input and at the output.

The generator is on continous run for the last 3.15 hours.

I'll leave it running until neighbours will complain about the noise.

Regarding the stranded wire:

Some time ago in a Bedini project I have built 2 identical coils but one with normal wire and another with stranded wire. I was using these coils to collect the power from the rotor powered with a Bedini standard circuit. Same core same wire diameter, all the same...

The results at that time (no load): normal wire output was 9.2 volts
stranded wire output was 12.3

since then I have always used stranded for most of my coils

it is easy to do the same experiment like me, actually it would be nice if someone else will confirm this.

I always try everything myself, I don't take all info I found as granted.

If I was wrong I would like someone to tell me.

@Groundloop

one more change to the drawing: input cap 47000uf

Yes I am religious, Christian Orthodox, God helped me many times in life.

I am curious to see how many will actually do anything, many are just waiting and waiting... don't know what.

Do not use shortcuts, if built like I said, referring to the coils and magnets arrangement then everything else is easy if not will fail. I will show you how many rotors I have made before this one worked, all others looked perfect but small differences.

Can you believe that I have ordered 2 of the acrylic rotors to a local company who uses laser cutting and I was expected to get a perfect rotor but... the centre hole is not centered and the spacing between the magnets on the rotor was not equal... I went crazy. I paid a lot of money for that operation to be done perfect and their excuse was that I was not very specific that it must be accurate... what will I expect from a laser cutting...

The one used now was ordered to another company that makes clock parts but the max thickness they worked with was 3mm. I have ordered 4 and glued them together. The actual rotor you see is made from 4 rotors 3mm thick each. The rotor must be strong and not bend.

Today I have ordered the magnets for the next build and what is left is again the stupid rotor.

I have to go again through the same pain, oh nooo...

All the best,

RomeroUK

Hi,

People should understand that when I am talking about stranded wire I am referring to a bunch of wires isolated from each other.

In my understanding litz wire is a bunch of wires unisolated like in a normal power cord.

I am specifying this just to make sure everyone understands.

English is not my first language, sometimes might have some mistakes...

Regards,

RomeroUK

The 2 driver coils are not next to each other, one coil is on one side and the other exactly on the other side.

All magnets on the rotor are all pointing same direction, as you look at the device all magnets are with South up. I have never tried to run it upside down because of the driving circuits but I will try

it having it on one side.

I don't have a magnet polarity measurement device.

stefan is asking about the relative position of the driving coils. Namely you have 2 pairs for driving purpose, and 7 pairs for power generation. Those pairs are evenly fixed on the stator plates. If we number the pairs clockwise from 1 through 9, and let the first pair be a driving coil pair, the question is, what is the number for the other driving pair?

coil 1 and 6 are the driving coils from the left to the right.

I will go back to some more work now, I'll answer other questions later.

Just look at the pictures he supplied you can easily see it on there:

driving coil 1 --- 4x generator coils --- driver coil 2 --- 3x generator coil

Hope that helps.

Hi,

I have measured the rotor and it is 20cm, sorry. I had so many changes and I also had a 25cm and a 35 cm rotor in another setup.

Diameter has nothing to do with the results if u space the magnets equally.

Based on previous tests larger diameter = better results.

All other dimensions are 100% correct.

I have just tried to have the device running on the side and even upside down.

On the side looks the same but upside down slows down a lot. It might be nothing, maybe the way the bearings are behaving in contact with the shaft, I am not sure yet.

I am trying now to have it suspended with a piece of cotton string and do a video.

Quote from: void109 on Today at 06:56:56 PM

I believe I read that he is using two hall sensors. I also believe I read that we are trying to activate the pickup coils at TDC of the magnet.

Which of those two statements are incorrect? Or both? With a 9/8 ratio of magnets to coils, and only two hall sensors to set trigger points, I don't see how it is possible for each of the coils to activate at the same relative position to the nearest approaching magnet. Looking at the CAD drawing woopy took a photo of illustrates this.

Wouldn't it be the case that each coil would need its own hall sensor?

Thanks Rom!

The 2 driving coils are running independently, not activating at the same time, that is what I need, to have the second coil activating when the other one is completely off.

End.