

# OTC-X1

COMPLETE DOCUMENT IN FOUR (4) PARTS.

**PART 3** - A guide to understanding useful information contained in Mr Otis T. Carr's 'Dimensions Of Mystery', latest research being conducted, design schematics for a 25" model OTC - X1 and other useful devices, other relevant information.

## A note to all:

Some will question my references to GOD. You are only possible because God is. Every being is a facet. The whole is oneness. The eternal light of creation. There is only sacred geometry. On the smallest level, beyond the atom, all things are the sphere. The center of this sphere is hollow. The only thing that remains when all is removed from a true vacuum, is aether. It is the nothing in between. That which is every where and no where all at once. This is your direct connection to all matter every where and every when.

Upon the mere contemplation of any idea, concept or anything directly or remotely associated with any idea and / or information and / or concept in part or in full, contained in this document renders that idea free for public use, REGARDLESS of how the contemplation or idea came about. Whether that be written, oral, text, conversation, obtained through dreams (or dream like states), second hand source, remote viewing (and associated techniques), clairvoyance (and associated techniques) or any other conceivable or non conceivable method of obtaining or understanding. The novel ideas and concepts contained within are expressed information of the information field rendering these concepts free for use throughout the entire universe / multiverse by any being. This information is for the betterment of all beings every where and every when. THIS IS NOT NEW TECHNOLOGY. This is potential information which has existed as the principles of creation since GOD consciousness permeated the entirety of all things. A beautiful man by the name of Nikola Tesla understands this and how to use it. That is why to date everything in this technological world of ours, all stems from him. IT MUST BE NOTED, Nikola only has the interest of the betterment of humanity as a goal. Others who use his technology, specifically governments and contractors associated with 'dis-harmony' projects are singularly responsible for what they have done with the information stolen from Nikola. Nikola knows the things they do are quite possible, but he only has love in his heart.

The authors of this series of three documents recognize and acknowledge there is no such thing as an original idea, not any one human can have an original idea. It is merely a fact of how well you are spiritually connected to the information field and the totality of all things. All information, that would be all truth, as only truth is information, is known and shown in the work of GOD, therefore no one can 'patent' that which is eternal universal truth. A meaningless man made law (wall) only applies in the realm of Maritime Law. The law of water, the law of bankers, the law of corporations. The government can not deal with private citizens, because you were created with sovereign rights, it can only deal with corporations. If the government wishes to engage you contractually, it has no choice but to create a fictitious entity which is the corporation of you. If you try to get your name put into lower case when dealing with these type of institutions you will quickly realize the computer software is written to convert your name directly into one of the three versions below displayed in red:

john smith - free and sovereign citizen of the multiverse



John Smith - Capitus Dimunutia Minima - first loss of rights

John SMITH - Capitus Dimunutia Media - can be fined but not imprisoned

JOHN SMITH - Capitus Dimunutia Maxima - rights of freedom totally given up, condition changes from free to a state of bondage where you can be fined and / or imprisoned for a period of time determined by the state.



Your very birth certificate is a contract with the government. So to are property deeds, property rates, social security, employment contracts, drivers licence, TAXATION and anything else with your name spelt in any other way, other than all lower case.

You as a free and sovereign citizen do not need any contracts with anyone.

You as a free and sovereign citizen are not bound to Earth.

This information is for all beings following the rules of creation.

This information is for humanity to use.

For everyone to benefit from and to forge a spiritual connection with everyone and everything, every where and every when.

You can not expect to be treated as free or exercise your right to freedom unless you let others do the same.

You must understand your reason for being and complete your life goal.

When you have only love in your heart, ONLY LOVE (this is not a blasé statement), then you have no need to be governed.

With the realization that everyone and everything, every where and every when is inevitably made from the same base geometry, you now realize we are not just made of the same stuff, we are in fact all one experience faceted over a universe.

The final note is this: to be free you must be. You must be the change you want to see.

light love balance



120  
A  
120

# OTIS-X1

## SPACE CRAFT

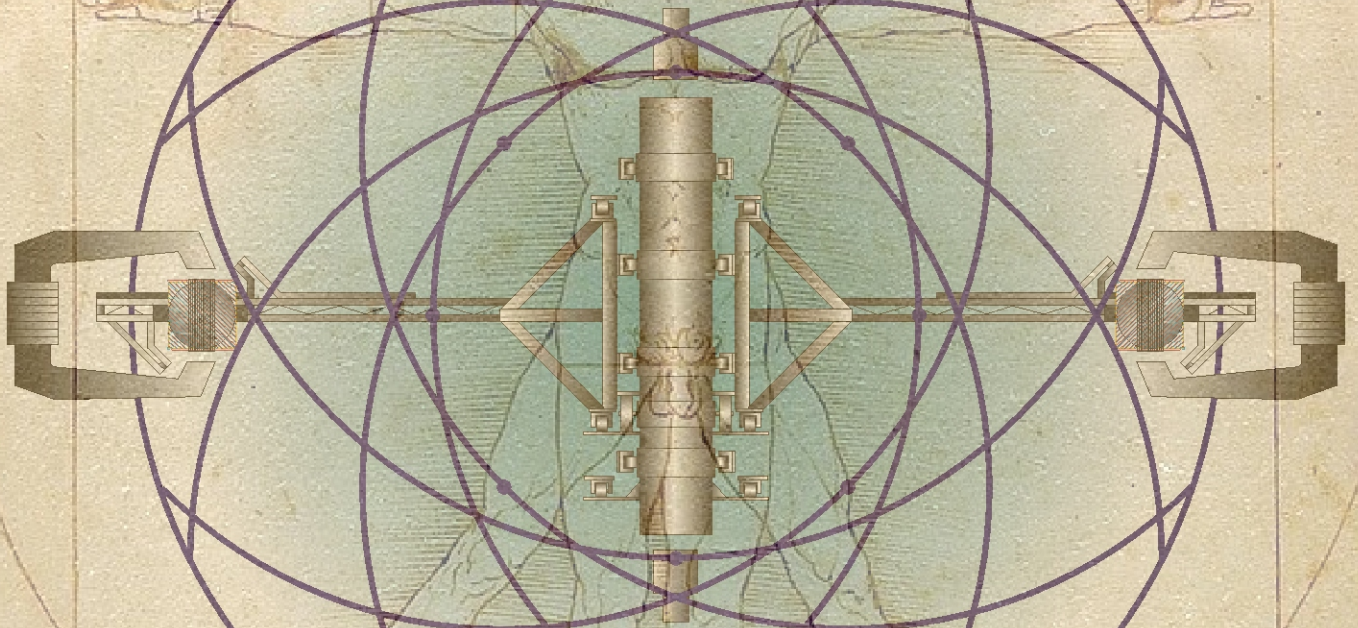

## CONSTRUCTION

# MANUSCRIPT

Introduction by

**Ralph & Marsha Ring.**

Including a guide to understanding  
useful information contained within

**Otis T. Carr's 'Dimensions of Mystery'**

B  
120

**NOW!  
NEW!**

**Build this  
AUTHENTIC MODEL  
of the REVOLUTIONARY**

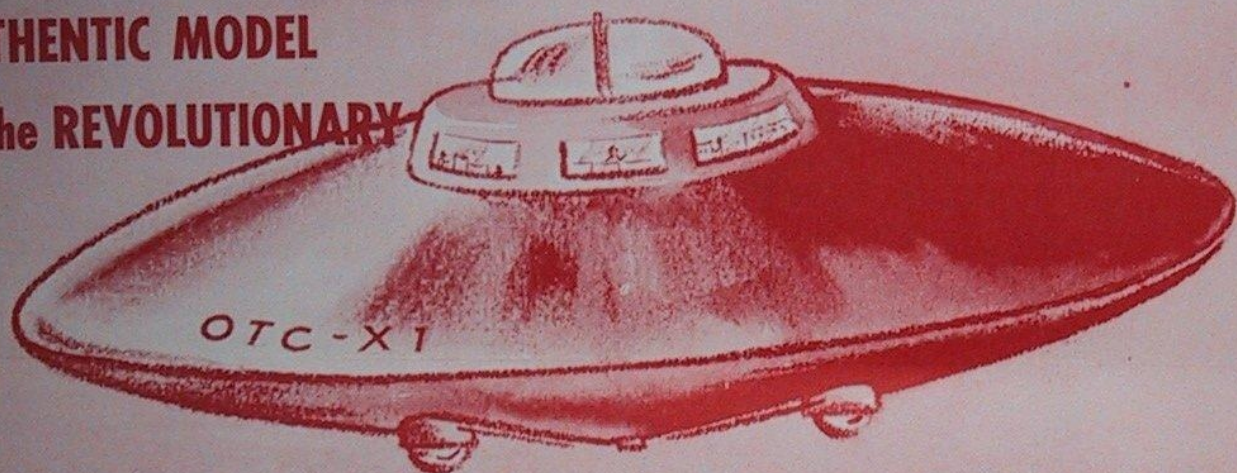

# OTC-X1 *SPACE CRAFT*

**Detailed Engineering Plans Now  
Available at Popular Prices!**

**ANIMATE IT! SEE IT WORK! EVEN FLY IT YOURSELF!**

(Under proper qualification, of course)

**T**his is an illustration of an actual model of the OTC-X1 —the craft now being engineered for a manned space flight to the moon on December 7, 1959! To enable interested people everywhere to keep abreast of the latest developments of the Space Age, OTC Enterprises, Inc., pioneer developer of *free-energy space flight*, has had the sensational and heretofore top secret master plans of this soon-to-be-built space craft rendered in model-maker's form and reproduced in quantity to achieve a price in everyone's reach. Read inside about this amazing new energy concept and the craft it will power—and the realistic model you will want to build of that craft!



Trademark of OTC Enterprises Inc

## Introduction

It is with Great Honor and Humility to have the opportunity to introduce this great work. For over 50 years this information has remained in obscurity. Otis T. Carr after being refused by the patent office for his ideas of levitation, was told if he pulled those ideas out of the patent, they would give him a patent for an amusement device. He was compelled to write "Dimensions of Mystery" which contained all of the simple and natural laws regarding levitation and wove them into pros and poetry. Carr made the comment that when the time is right for this information to surface and be used again it will be decoded and unwoven by someone of great vision, patience and love for humanity. That person, Benn Hallett, has now come forth resonating from etheric consciousness to decode in such a loving, beautiful and senseful way the "Dimensions of Mystery." This literary gift provides the reader with a kind of aerial map of unfolding messages. It also portrays a man, Benn Hallett, passionate about presenting truth in as clear, practical and real a way as possible. It is a close up of a man and a message alive with the inner flame of spirit and in touch with the consciousness of great Minds and Hearts such as Nikola Tesla, Viktor Schauberger, Walter Russell, Rudolph Steiner, Albert Einstein, Henry Moray, and Otis T. Carr. This work is only the tip of the ice burg, the beginning that will eventually take us home to the stars and beyond. It has now become possible by this work more than ever before to bring about free and abundant energy for everyone. With Respect, Honor and Love in our Hearts for this Great Man.

Ralph and Marsha Ring

To whom it may concern:

I am. I am also aware of the significance of the information contained in this, my guide to understanding useful information in Mr Otis T. Carr's 'DIMENSIONS OF MYSTERY'. This is what I see written when I read the words of a beautiful man. To me the story seems lost when translated. I understand what I understand from the original 'DIMENSIONS OF MYSTERY' through studying the subject matter at hand. I have had no more or less available to me than is available to anyone with a genuine interest in the betterment and prosperity of Humanity and above all a conscious objective to continue the Christ work of enlightenment and awakening back to the way of oneness with Gaia and the harmony of pure love and all conscious creation. As of now, I here by release, to my knowledge for the first time publically since it was written, a guide to understanding useful information contained within Mr Otis T. Carr's 'DIMENSIONS OF MYSTERY' in order to perform the task of: 1) UNDERSTANDING, 2) building and 3) using a working OTC - X1. It must be understood that the simple act of understanding how to understand can be a monumental task if looked at from the wrong angle. That statement in itself poses a question? Why did I choose the word 'angle'? Answer, It is a direct reference to geometry (ge ome tree) and dimensional planes of existence. It is also a direct association to the words angel and angelic, leading one to the assumption that specific angles lead to angelic forms. Such is the case when the point of Sacred Geometry is brought into the equation. Once again by my using the word 'point' I am signifying that Sacred Creation Geometry begins from a point. From this 'point of creation' is formed a line, the line forming a circle from whence is birthed the sphere. This sphere contains the entirety of all geometry. When one looks at the basic forms of geometric structure we see in our world today, they can be easily explained like this:



Otis T. Carr & 'Long' John Nebel with a model of the OTC - X1.

Sacred geometry - pertaining spiritual creation. Adhering to the rules set forth by, in and for all infinite co - creation.

Functional geometry - pertaining the esoteric geometry used in modern city planning to accumulate from the energy grid.

Aerodynamic geometry - pertaining the inertial based transportation and aircraft industry.

Hydrodynamic geometry - pertaining the inertial based water craft industry.

Electrodynamic geometry - pertaining the layout of electrical circuits.

Aesthetic geometry - pertaining designs which are 'appealing to the eye' regardless of functional ability or practicality.

As of now we are only concerned with sacred geometric arrangement and construction.

This is the most detailed public document available concerning Otis T. Carr and his Aetheric gravitational device known

as the: **OTC-X1**

**IMPORTANT NOTE:** This manuscript which you are about to read is a step on your path of curiosity. In these pages are all the answers one needs to understand why. I understand this book may still seem a little hard to comprehend to some, my advice is to understand something about sacred geometry in order to understand the contents of this book and the process of Aetheric energy accumulation and conversion into free abundant usable energy. Two ongoing years of research, a reference library of over two thousand five hundred books at my disposal freely downloaded from the internet, a lot of books I have been given, a few I have bought and thousands of hours of documentaries on television, internet and dvd have culminated to produce this work.

Anyone attempting to see this process through, by that I mean the creation of an OTC - X1, must understand this is a conscious creation process. The creator works in symbiosis with the creation to birth the principals into being. The true aim of this process is for the creator of the craft to realize the actuality that in fact it is a training device and you yourself are a biological zero point Aetheric energy inter - dimensional teleportation device, capable of accessing each and every plane of dimensional existence through the process of harmonic sympathetic resonance or sympathetic resonant frequency.

Finally, I urge all to use their own power of investigation to understand these and many more concepts for themselves. I do not view this work as a translation, it is a guide, it is what I understand.



Norman Colton with 'Long' John Nebel viewing a larger unmanned model.

# INNER DIMENSIONS

A guide to understanding useful information contained within

Otis T. Carr's 'DIMENSIONS OF MYSTERY'.



DIMENSIONS OF MYSTERY

A Message for the Twentieth Century

A Me Stone Sage for the Twentieth Century.



Pronounced: may

“.....What doth the Lord require  
of thee, but to do justly and to  
love mercy and to walk humbly  
with thy God?”

Micah 6:8

Mica 6:8, ratio / scale. Working from the dimensions of the forty five foot craft, this gives us the thickness for the dielectric medium of the ‘equatorial field correlator’ of 3/4” (three quarter inch). When using bonded mica as a dielectric, use pure shellac bonded mica. Mica - the substance, 6:8 - the ratio, set in a spiritual context reflecting the importance of Mica. This passage also alludes to oneness “walk humbly with thy God”, a bringing together, a correlation, as this is the function of the ‘equatorial field correlator’. Mica is used for very good reason. Mr Tesla, a man who has helped me an immense amount, used the highest grade mica for its dielectric properties due to its high potential applications as a dielectric. It is useful to note that human skin and hair both sit higher on the dielectric scale than mica. A very useful piece of knowledge considering the abilities of the human body. By using a high quality mica dielectric the two plates of a capacitor may be placed much closer together without risk of conductance between each plate. The mica dielectric can accept a much higher charge and heat than most other dielectric mediums and is absolutely organic. This is a major factor in the conscious intent when creating this craft. Aetheric energy accumulation requires sacred geometric design and construction as well as the use of pure organic dielectrics in order to obtain and control useable energy from the Aether. Mica bonded with shellac is absolutely organic and fits perfectly in the design of this craft. Shellac is made of the female lac bug, meaning it is a pure organic, being that it is essentially made (on an atomic level) of the same creation geometry as the Human body and therefore all sacred creation.

Conscious Projection  
DEDICATIONS TO

Conscious Transmutation of Energy

Miss Adele Tippett, who innocently inspired lethargy into action.

Mat: from the Egyptian Goddess Maat or Maati meaning truth, balance.  
 The ostrich feather of Maat is the feather of truth used to weigh against the heart in the underworld, with Anubis tending the scales.



Conscious Feeling

My wife, Eleanor, whose love and sacrifice in the beginning made this work possible.

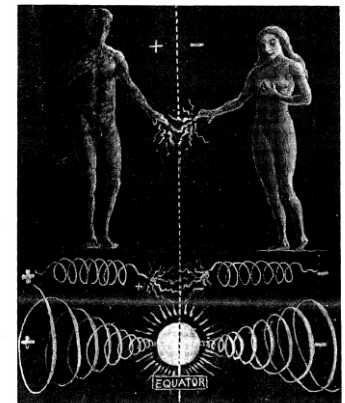
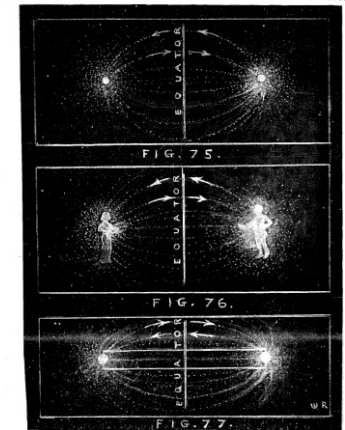

FIG. 68. NATURE CREATES BODIES BY POLARIZING AN EQUILIBRIUM CONDITION. NATURE OPPOSITE BODIES BY DEPOLARIZING THEM. NATURE REPEATS BODIES BY VOIDING THEIR POLARITY THROUGH INCREASING DISTANCE THEIR OPPOSITE CONDITIONS. ALL BODIES ARE INFINITELY EXTENDED.

Conscious Emotion

God and Country and all men of good will.



GOOD IS LIGHT --- AND GOD IS LOVE  
 LOVE IS DIVIDED INTO PAIRS OF OPPOSITES --- GIVING AND RECEIVING  
 RADIATION IS THE ACTION OF GIVING. ITS REACTION IS GRAVITATION.

Conscious Thought

and to the Memory of my father and mother.

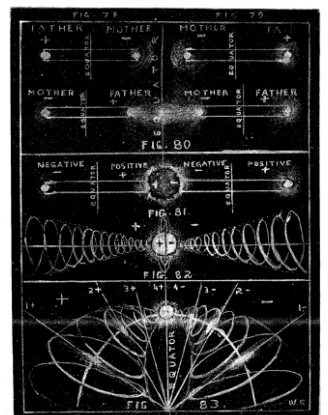

ILLUSTRATING THE FATHER-MOTHER PRINCIPLE OF BUILDING BODIES BY DIVIDING LIGHT INTO POLARIZED UNITS--AND REPRODUCING BODIES BY UNITING TWO WAVE-FIELDS OF OPPOSED UNITS INTO ONE. -- SEE TEXT.

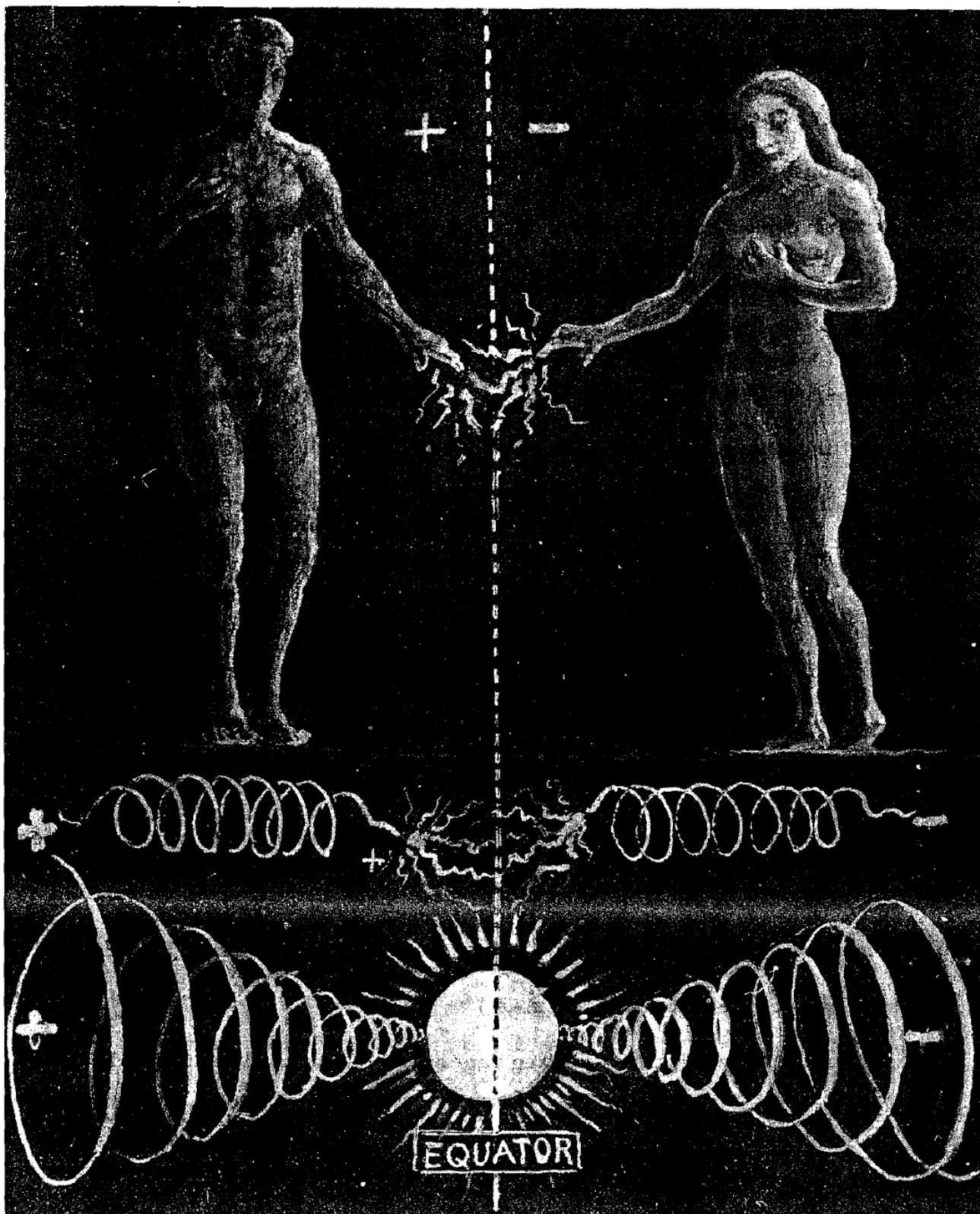
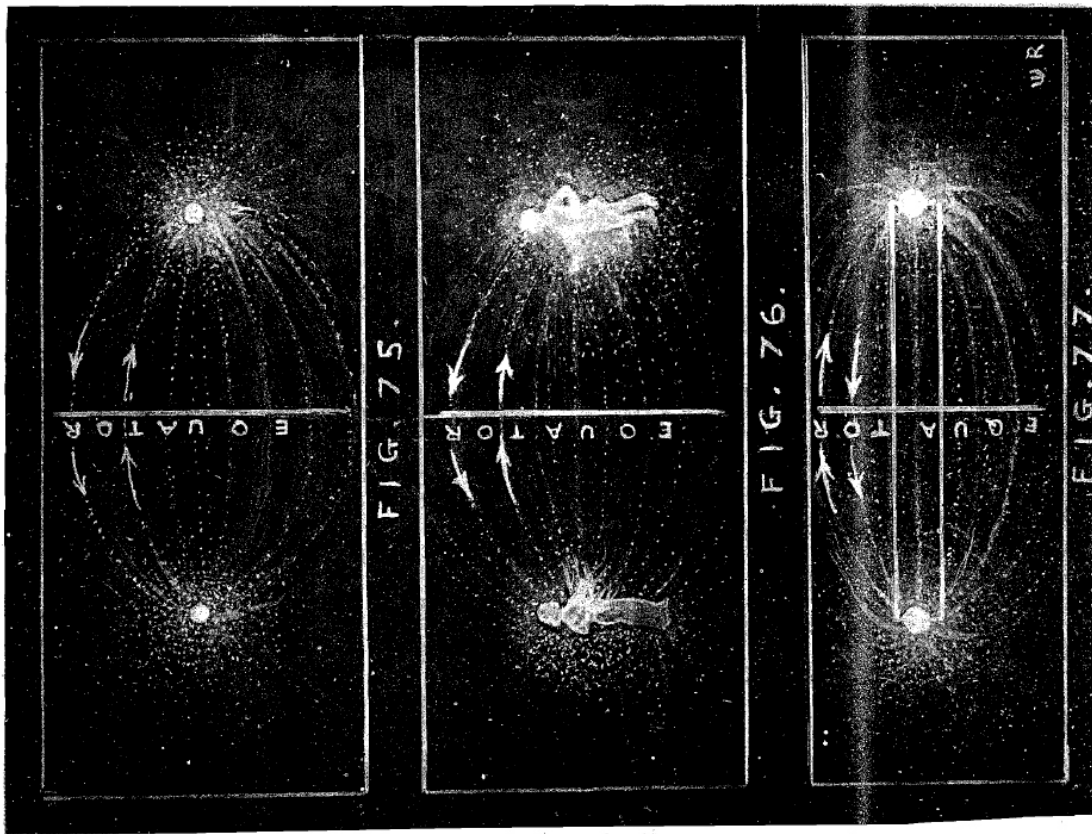

Fig. 68.

NATURE CREATES BODIES BY POLARIZING AN EQUILIBRIUM CONDITION. NATURE DESTROYS BODIES BY DEPOLARIZING THEM. NATURE REPEATS BODIES BY VOIDING THEIR POLARITY THROUGH INTERCHANGE BETWEEN THEIR OPPOSITE CONDITIONS. ALL BODIES ARE INFINITELY EXTENDED.



GOD IS LIGHT --- AND GOD IS LOVE  
 LOVE IS DIVIDED INTO PAIRS OF OPPOSITES --- GIVING --- AND RECEIVING  
 RADIATION IS THE ACTION OF GIVING. ITS REACTION IS GRAVITATION.

Walter Russell

**THE SCIENCE OF THE FUTURE IS BASED UPON GOD - THE CREATOR.**  
**GOD IS LIGHT - GOD IS MIND**  
**MIND IS ALONE OMNISCIANT AND OMNIPOTENT --- LIGHT IS ALONE OMNIPRESENT**

<p>THE UNDIVIDED WHITE LIGHT OF THE UNIVERSAL GOD-MIND</p>	<p>THE WHITE MIND-LIGHT DIVIDED INTO SPECTRUM PAIRS.</p>	<p>SENSE VISION RANGE</p> <p>THE HULL MARK</p>	<p>EXTENDED SENSE RANGE</p> <p>360°</p>
<p><b>GOD'S UNIVERSE OF "SPACE" IS AN INTENSELY LUMINOUS BLINDING WHITE LIGHT WHICH NO EYES CAN SEE.</b>  <small>ILLUMINATES ALONE. CAN SEE THAT LIGHT THROUGH THEIR CENTERS OF CONSCIOUSNESS LOCATED IN THEIR FINICAL GRABBS.</small></p>	<p><b>GOD'S WHITE MIND-LIGHT IS DARK TO MAN UNTIL HE DIVIDES IT INTO SPECTRUM PAIRS OF RED AND BLUE LIGHTS TO SCREEN THE WHITE LIGHT OF GOD'S MIND WHICH CENTERS EVERY CREATING THING</b></p>	<p><b>MAN'S SENSES ARE TWO-WAY WAVES OF LIMITED FREQUENCIES. THEY DO NOT RESPOND TO VIBRATIONS BELOW OR ABOVE A VERY LIMITED RANGE</b></p>	<p><b>MAN CAN EXTEND HIS RANGE OF SENSE VISION BY TELESCOPE OR MICROSCOPE, BUT HIS SENSES CANNOT GO BEYOND SPECTRUM EFFECT INTO MIND CAUSE.</b></p>
		<p>THE STONE</p> <p>GRAVITY PART OF THE STONE</p>	
<p><b>MAN'S LIMITED SENSE VISION HAS CAUSED HIM TO SEE AN OBJECTIVE UNIVERSE OF MANY SEPARATE DISUNITED THINGS. WHEN MIND-VISION UNFOLDS TO A HIGHER STAGE IN THE HUMAN RACE, BY INCREASING AWARENESS OF THE DIVINE LIGHT WHICH CENTERS MAN, HE WILL THEN SEE THAT EVERY THING IN THE UNIVERSE IS INSOLUBLY BOUND TO EVERY OTHER THING. SCIENCE WILL THEN KNOW THAT MATTER IS BUT MANY FOCAL POINTS OF ONE BODY.</b></p>		<p><b>WHEN A MAN MULTIPLIES GRAVITY BY CASTING A STONE IN THE WATER, HIS SENSES SEE ONLY WAVE-RIPPLES. THEY DO NOT TELL HIM THAT THOSE RIPPLES ARE EQUATORIAL RING-BANDS OF EXPANDING SPHERES WHICH ARE DISSIPATING GRAVITY IN THE SAME RATIO AS IT IS BEING MULTIPLIED BY THE FALLING STONE. THE SAME PRINCIPLE APPLIES TO ALL ACTIONS. THIS IS, IN FACT, THIS IS THE VERY BASIS OF THE UNIVERSAL LIFE PRINCIPLE.</b></p>	
<p><b>SCIENCE HAS BUILT A STRANGE UNIVERSE FROM SENSE EVIDENCE, AND HAS BEEN MIGHTILY DECEIVED.</b></p>			

The Science Of The Future Is Based Upon GOD by Walter Russell

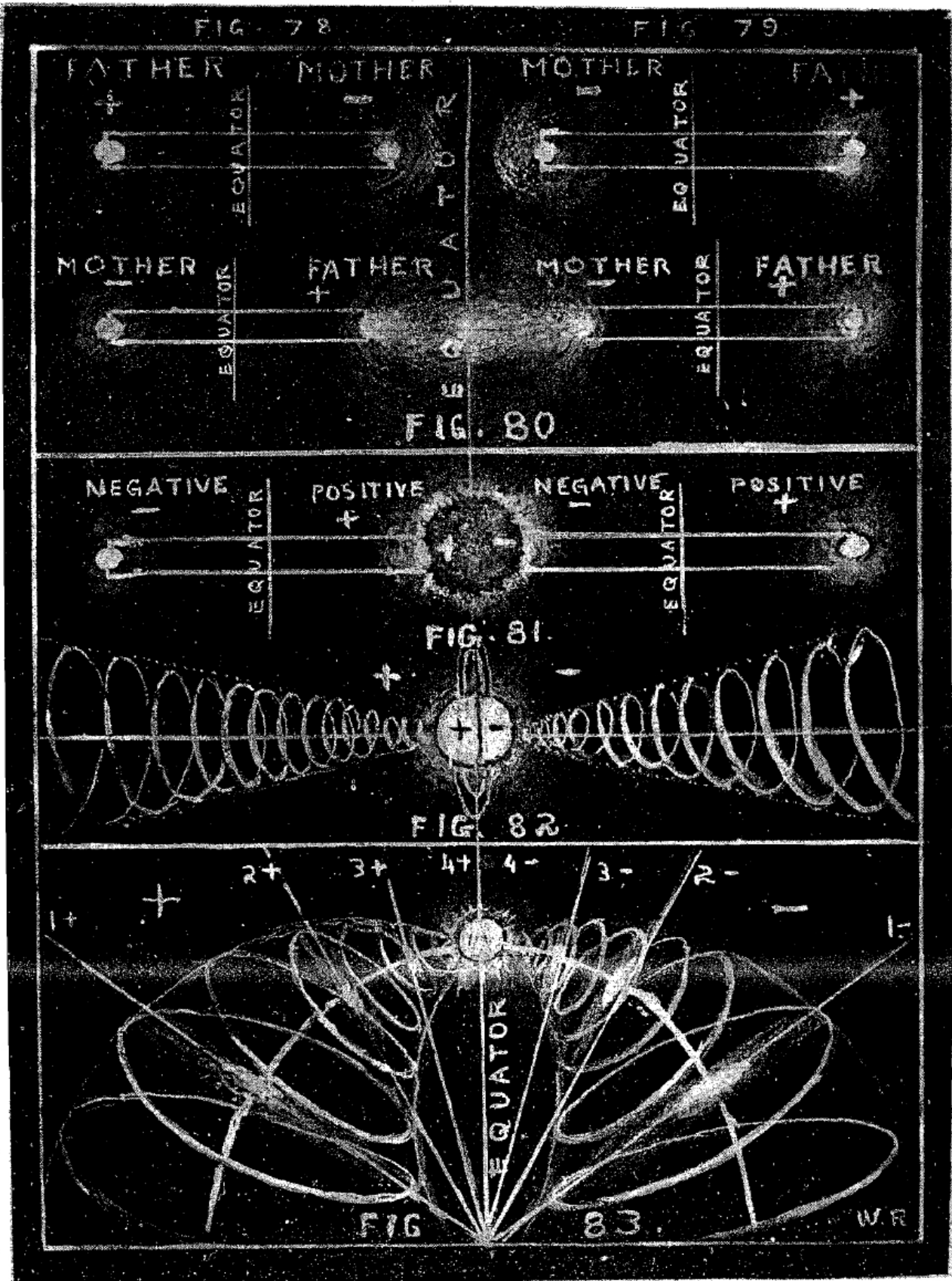

ILLUSTRATING THE FATHER-MOTHER PRINCIPLE OF BUILDING BODIES BY DIVIDING LIGHT INTO POLARIZED UNITS--AND REPRODUCING BODIES BY UNITING TWO WAVE-FIELDS OF OPPOSED UNITS INTO ONE. -- SEE TEXT.

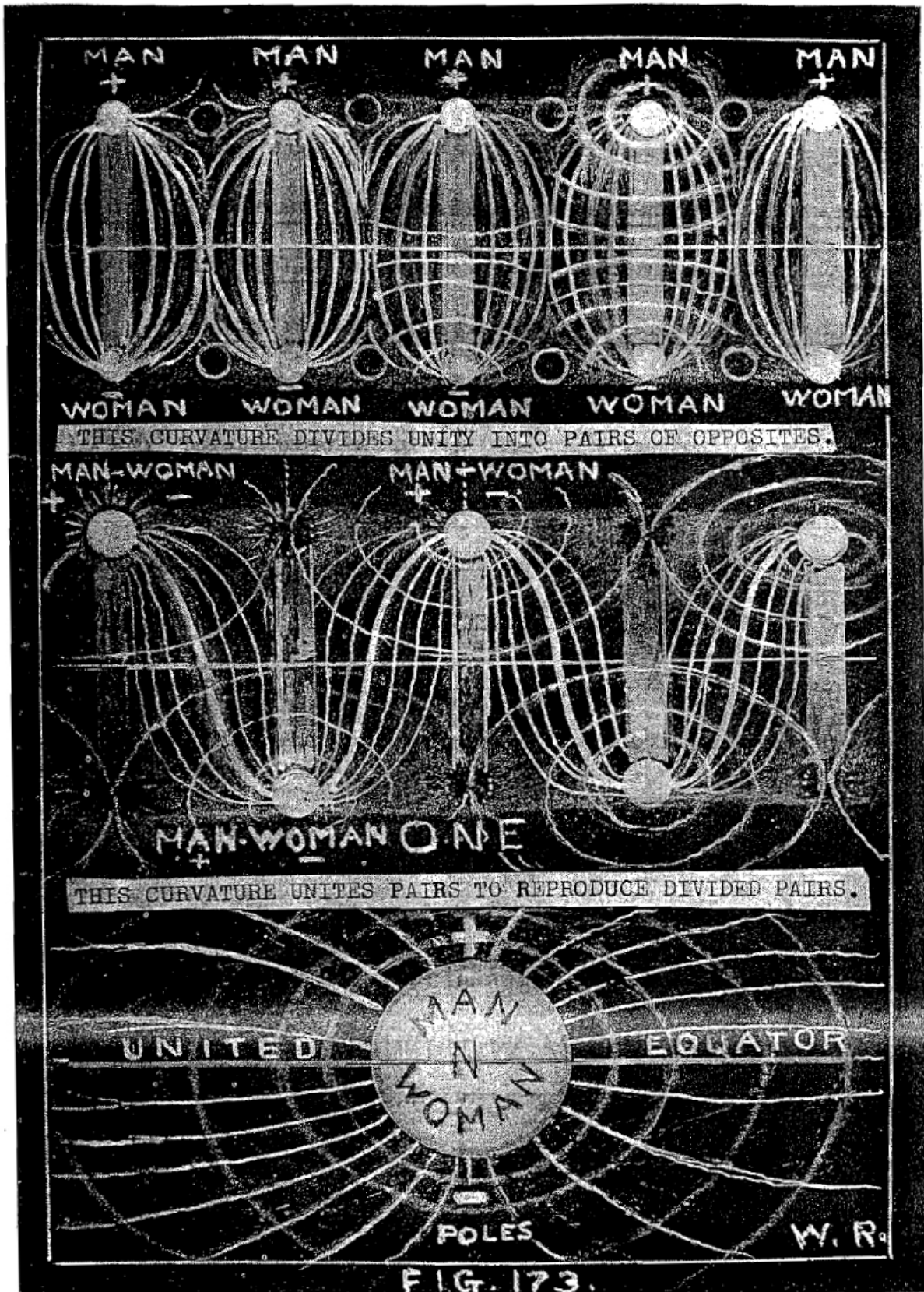

NATURE IS FOREVER DIVIDING THE UNITY OF FATHER-MOTHERHOOD INTO SEX DIVIDED FATHERS AND MOTHERS WHICH UNITE INTO THE ONENESS OF FATHER-MOTHERHOOD TO MULTIPLY SEX DIVIDED FATHERS AND MOTHERS.

Nectar - aether, fluid, water, blood (always present)  
Pollen - static accumulation(the static comes an goes)

SCENT SENSE

The nectar in a rose  
And other blossoms, too,  
Is God's perspiration  
Put there for me and you!

And the busy little bee  
Treats the evidence of God's toil  
In a matter chemically,  
Leaving behind for mortal man  
A sweet taste of mystery!

The product of the geometry of the flower of life  
And other sacred geometric arrangements  
Is the eternal life force energy of the creator  
For all to freely use.

When the fields of magnetism  
Interact with the aetheric field  
Transmutation  
Leaving for the non spiritually aware  
A taste of who they are and of possibility





### WOODLAND FABLE

Springtime merging into summer had come to the beautiful Allegheny mountains and the region of this tale was alive with the brilliant foliage of the forest.

Where there are mountains, there are valleys, and at the entrance of a valley, set between two mountain peaks, a turbulent and fast-moving stream of water, known as Jordan's Run, wound its way joyously and with abandon toward its ultimate destination - the historic Potomac River and thence to the sea.

On a hillside facing the west, the first patch of wild strawberry plants had shed their blooms a moon past and full-grown berries were awaiting the kiss of the afternoon sun to ripen into their brilliant red fulfillment!

A wild morning glory, much too shy and proud to gaze upward at a noonday sun, softly folded the petals of its blue bell. And a large bumblebee, that had forced its way into the very heart of this pale, delicate blossom to gorge the nectar and filch the pollen without conscience, angrily emerged from this frail trap and, with a buzzing roar and wicked stinger exposed, sped toward his nest with his booty, daring any and all to get in his way!

The forest was alive with a gay symphony of

Numbered by line.

Nectar - aether (the aether always present)

Pollen - static accumulation(the static potential)

Title) WOODLAND FABLE is an equation of degrees for sacred geometry.

Equation: 13 letters, 2 words, the double 'OO' signifies a different number.

1 11 11111 11111 = the space is the decimal point = 26.5 degrees. Specific to phi ratio geometry.

1) Birth and re-birth - generation and regeneration.

Alleg-(h-en)-y : the 'h' says use your mind and pull out the proceeding 2 letters, the vowel and the consonant, knowing they are interchangeable remove the 'h' as it is a marker an replace them with the intended letters of 'o' and 'r' then we have Allegory, meaning 'the description of one thing under the image of another'.

2) Allegheny (Allegory) Mountain(s) plural, plural suggests plurality, equality, two mountain peaks these being both halves of the central accumulator, the 'region' referred to being the central point or valley between the two mountains.

3) The brilliant foliage of the forest is the progression of static build up and accumulation in the vortex arrangement. In a tree the root structure and vortex system exists above and below as with all creation. The leaf structure is the top of the static vortex extending above the top cone of the central accumulator and the root structure is the bottom half of the static vortex with the roots beginning just above the water level of the valley or neutral center containing as all rivers do the 'water'.

In actuality the water is the Aether as known by adepts. Aquarius, the water bearer, pours the life blood or Aether from the vessel.

4) The center, mirror image, 'there are valleys' - 'there's a re valley' 're' or ray or or Aetheric light of electromagnetic accumulation in the 'valley' or 'neutral center' of the accumulator. It will be further evident upon observation of the part construction drawings that there is a resonance chamber in the center of the accumulator.

5) The point where the pressure difference is greatest between the two halves of the central accumulator. Neutral center.

6) This is the point of Aetheric field compression - expansion.

7) Jordan's Run = Sound / Octave relationships / pure wave form / frequency the elements of the complete periodic table of creation, also the creation tones of Solfeggio scale, harmonic scale of creation tones which are the frequencies by which the energy field is harmonized to and is interacted with. The 'J' and the 'R' are shown below.

- 1. Ut = 396 = 9
- 2. Re = 417 = 3
- 3. Mi = 528 = 6
- 4. Fa = 639 = 9
- 5. Sol = 741 = 3
- 6. La = 852 = 6
- 7. Si = 963 = 9
- 8. Ut = 174 = 3
- 9. Re = 285 = 6

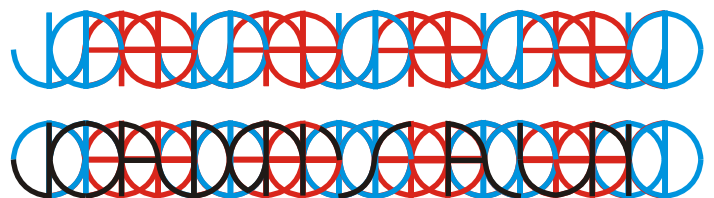
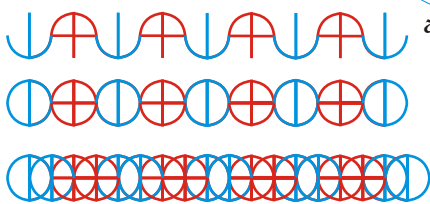
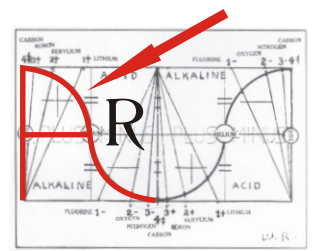
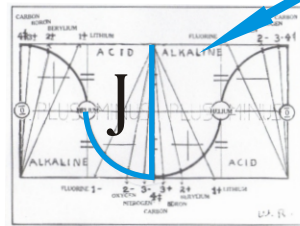
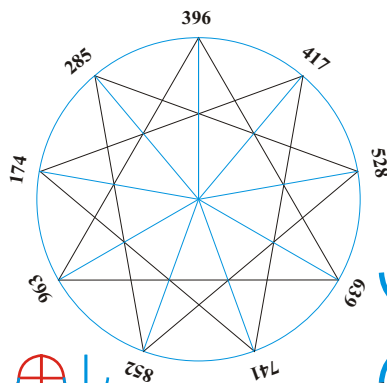

JORDAN'S RUN

J O A D A N ' S R U N

One of the nine octaves of the elements of matter by Walter Russell.

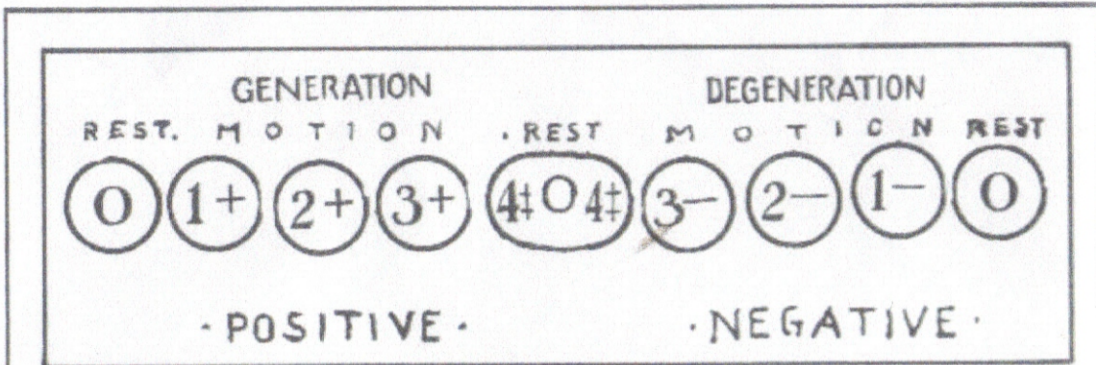

FIG. 87

OCTAVE WAVES OF VIBRATING LIGHT, WHICH CONSTITUTE THE ELEMENTS OF MATTER, CONSIST OF FOUR PAIRS OF TONES CENTERED BY A ZERO OF REST WHICH CONTROLS THEIR BALANCE FROM WITHIN, AND ARE BOUNDED BY TWO ZERO POLES OF REST WHICH CONTROL IT FROM WITHOUT.

WHEN ANY OF THESE TWO EQUAL PAIRS OF OPPOSITE TONES ARE UNITED, THEY BECOME STABLE - SUCH AS SODIUM CHLORIDE. WHEN THEY BECOME DISUNITED, THEY ARE THEN UNSTABLE - SUCH AS SODIUM AND CHLORINE.

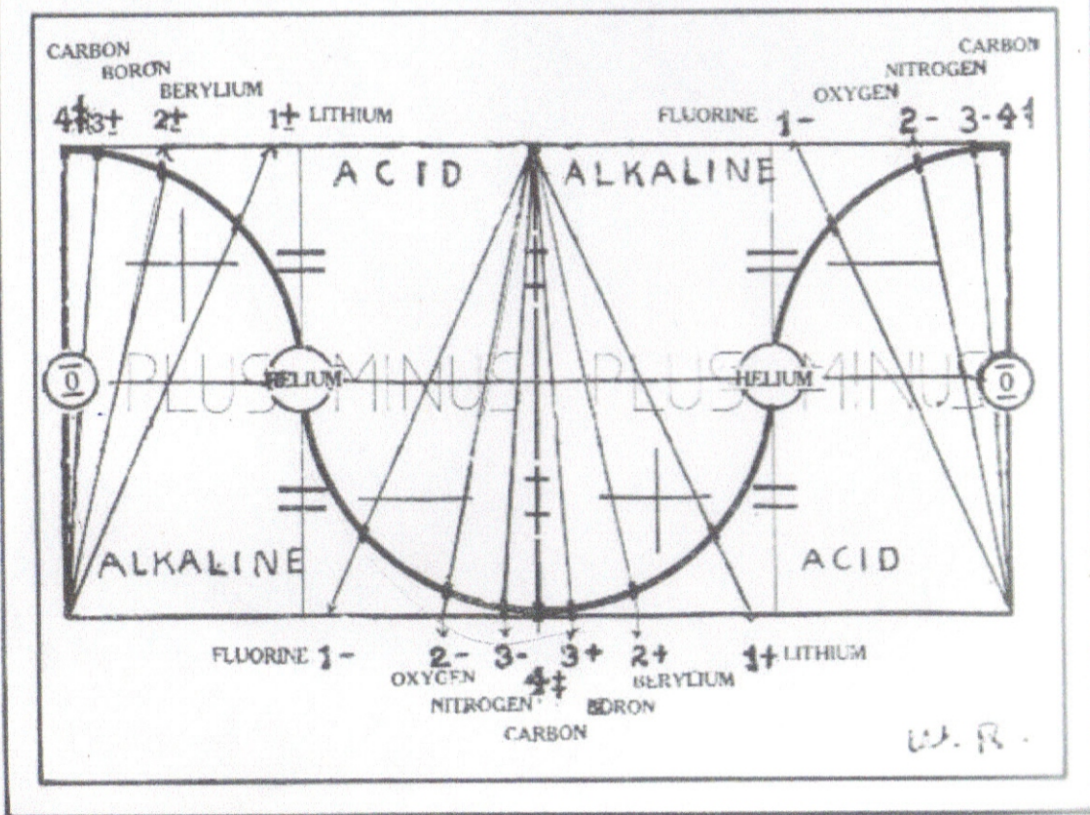
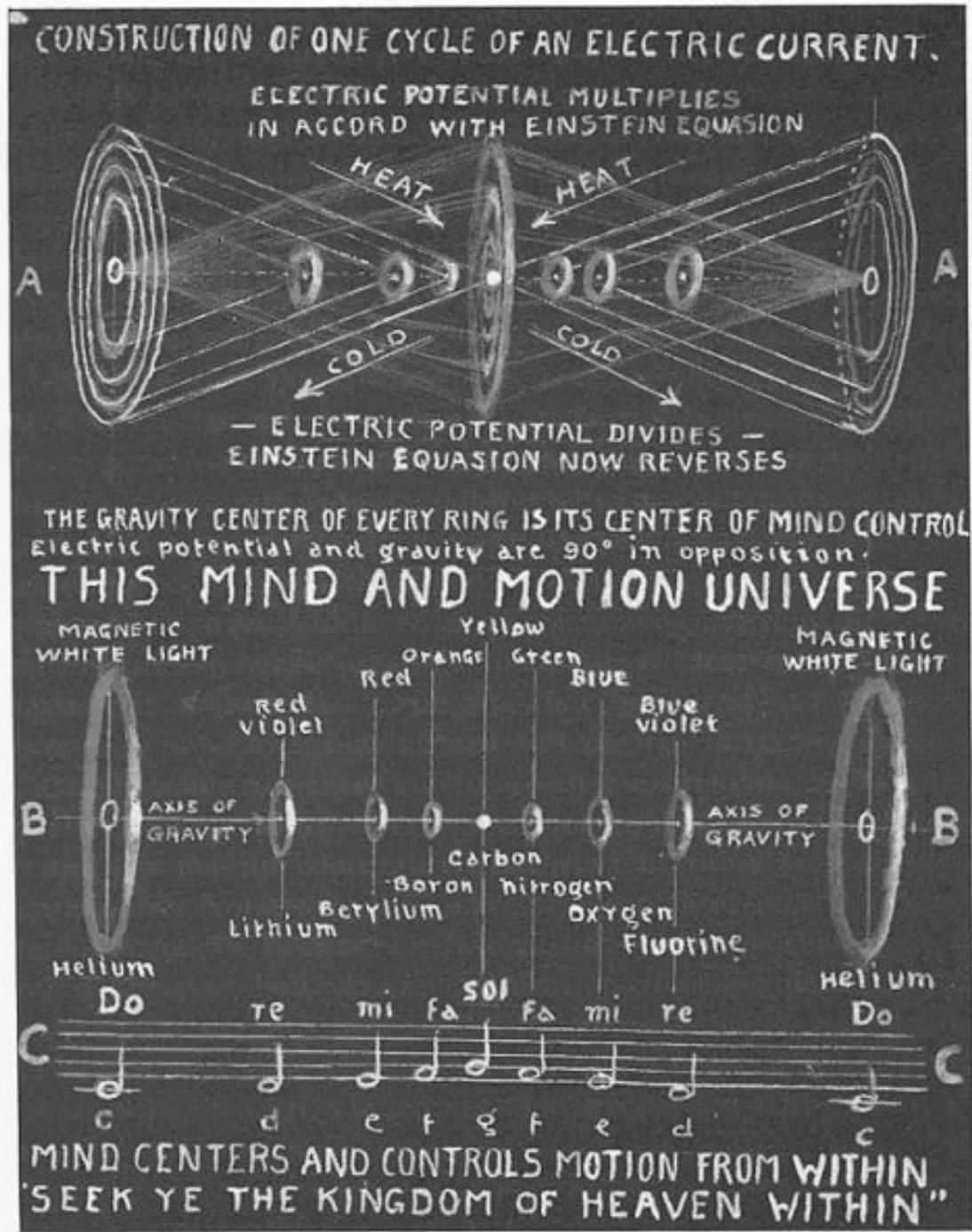
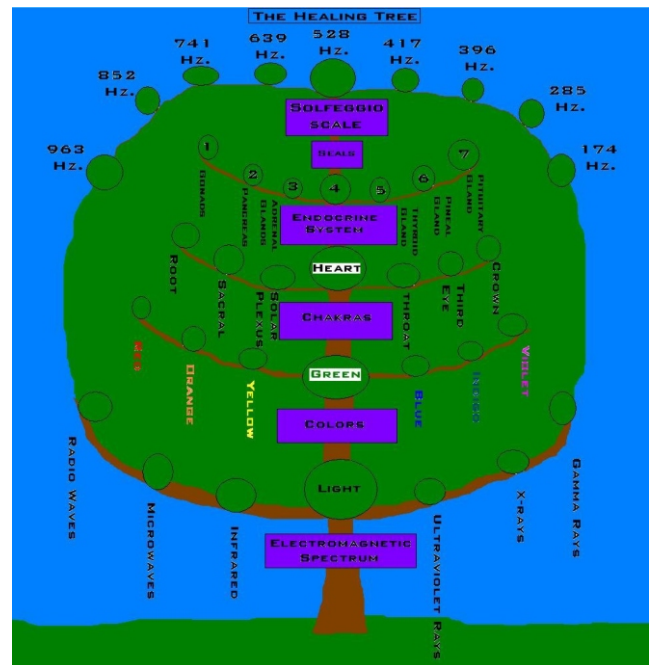

Fig. 88

SHOWING ONE OF THE NINE OCTAVES OF THE ELEMENTS OF MATTER.



THE HEALING TREE								
SOLFEGGIO SCALE								
963 Hz	852 Hz	741 Hz	639 Hz	528 Hz	417 Hz	396 Hz	285 Hz	174 Hz
SEALS								
ENDOCRINE SYSTEM								
	1	2	3	4	5	6	7	
	GONADS	PANCREAS	ADRENAL	THYMUS	THYROID	PINEAL	PITUITARY	
CHAKRAS								
	ROOT	SACRAL	SOLAR PLEXUS	HEART	THROAT	THIRD EYE	CROWN	
COLOURS								
	RED	ORANGE	YELLOW	GREEN	BLUE	INDIGO	VIOLET	
ELECTROMAGNETIC SPECTRUM								
	RADIO WAVES	MICROWAVES	INFRARED	LIGHT	ULTRAVIOLET	X - RAYS	GAMMA RAYS	



Where there are mountains, there are valleys,  
and at the entrance of a valley, set between two mountain  
peaks, a turbulent and fast-moving stream of water, known  
as Jordan's Run, wound its way joyously and with abandon  
toward its ultimate destination - the historic Potomac  
River and thence to the sea.

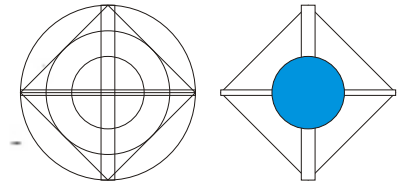

- 8, 9) Towards the resonance chamber of the central accumulator, 'the historic Potomac' or 'hi po stor atomic eth c' = the high potential storage of atomic Aetheric light (energy). It is the 'turbulent fast - moving stream' or vortex, the 'storage' term refers to the geometric structure, it is naturally accumulating Aetheric energy. So it would read:

Towards the center of the accumulator, the high potential storage of safe atomic Aetheric energy and thence the sea of magnetic radiation created by the pulsing 'C' shaped magnets.

- 10, 11, 12, 13, 14) Side and top elevation reference, referring to the western side of the design layout and energy flow, must be considered in the mind from a 3d design layout perspective. This is the progression of the FIRST action / reaction / mutation /transmutation of 'strawberries' or Utron's passing through the pulsed magnetic fields.

'On a hillside facing west, the first patch of strawberry plants had shed their blooms a moon past and full-grown berries were awaiting the kiss of the afternoon sun to ripen into their brilliant red fulfillment'

= As the initial rotation begins the capacitors are repelled and Utron's pass through 'moon' or 'C' shaped magnets transmutating the remainder of the energy back to the center. The progression of the strawberry ripening is transmutation of the sun's  $10^{12}$  hertz frequency. A geometrically designed commutator provides a circuit breaker system, this being the initiated pulse sequence required to pass the electrons through the magnetic field, instantaneously instigating regeneration upon exiting the magnetic field of the 'C' shaped magnets allowing the utron to perform its function of transmutation.

- 15, 16, 17, 18, 19, 20, 21, 22, 23) The 'wild morning glory' is the exact sacred ratios by which this geometric arrangement is to be constructed. Sacred geometry teaches us that 5 is the number of man and he may thereby understand his relationship to all things through the mathematical equations and geometric arrangements of all natural creation.

'Much too shy and proud to gaze upward at a noonday sun' - side elevation of design, pentagon (5) geometry.

'Softly folded the petals of its blue bell.' Draw the fold line of the petal at the top or the half circle at the base of the geometry, flip it over and place it at the top. 'The large bumblebee is the  $1:\sqrt{2}$  relationship in the 'heart' or center of the geometric arrangement. This is the natural Aetheric accumulation area, where it is filched, or taken, in the form of static, 'angrily emerged' - enormous power being released from delicate geometry and with a pulsed frequency, transmuted energy is aimed from the altitudinal direction of the Utron's in the interior rotating assembly to the central shaft on a 45 degree angle completing the cycle of mutation - transmutation back to the central accumulator.

'The forest was alive with a gay symphony of sound' - this is the point where every part of the microcosm is in active sympathetic resonant harmony with each other.

RATIO	SOURCE	RECIPROCAL (fraction = $\frac{1}{\text{ratio}}$ )
$\sqrt{\quad}$		
1.000	$=\sqrt{1}$	$=1.000$
1.272	$=\sqrt{\phi}$	$=0.786$
1.4142	$=\sqrt{2}$	$=0.707$
1.618	$=\sqrt{2.618}$	$=0.618$
1.732	$=\sqrt{3}$	$=0.577$
2.000	$=\sqrt{4}$	$=0.500$
2.236	$=\sqrt{5}$	$=0.447$

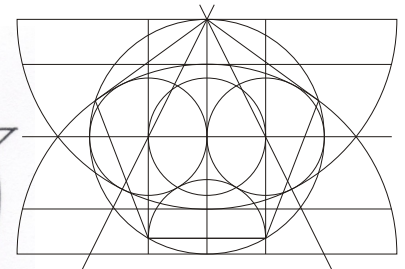
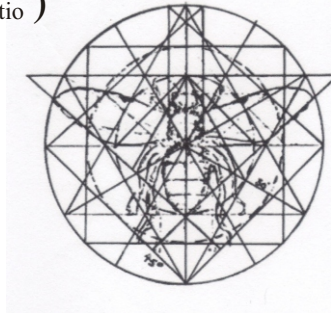

Geometric measurements for 25" or 63.5cm diameter.

	$25 / 2$	$(1 / 2)$	$= 12.5000000"$	$31.75000\text{cm}$
	$25 / \phi$	$(1 / \phi)$	$= 15.4511740"$	$39.24300\text{cm}$
○	$= 25 / \phi \times 2$	$(1 / \phi \times 2)$	$= 30.9023480"$	$78.49196\text{cm}$
	$25 / \phi^2$	$(1 / \phi^2)$	$= 9.5495514"$	$19.62299\text{cm}$
□	$= 25 / \phi + 25 / \phi^2$	$(1 / \phi + 1 / \phi^2)$	$= 25.000725"$	$63.50184\text{cm}$

The following two (2)  
pages are from the book:

Robert Lawlor

Philosophy and practice

sacred geometry

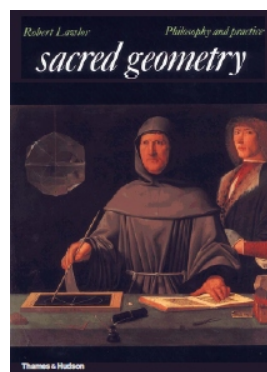

## VII The Squaring of the Circle

There are a number of diagrams in the literature of Sacred Geometry all related to the single idea known as the 'Squaring of the Circle'. This is a practice which seeks, with only the usual compass and straight-edge, to construct a square which is virtually equal in *perimeter* to the circumference of a given circle, or which is virtually equal in *area* to the area of a given circle. Because the circle is an incommensurable figure based on  $\pi$ , it is impossible to draw a square more than approximately equal to it. Nevertheless the Squaring of the Circle is of great importance to the geometer-cosmologist because for him the circle represents pure, unmanifest spirit-space, while the square represents the manifest and comprehensible world. When a near-equality is drawn between the circle and square, the *infinite* is able to express its dimensions or qualities through the finite.

### Workbook 7

#### Squaring the circle

In the following pages I will invite you to follow a squaring of the circle which I feel contains many symbolic keys for the contemplation of universal creation. We begin by drawing a circle, acknowledging it as the geometric metaphor for a homogeneous, non-differentiated space. As in our other diagrams, this unity-space must divide into duality in order to create. So we begin by dividing the unity-circle into two halves, a division which occurs within the initial unity.

**Drawing 7.1.** Draw a circle with centre  $O$  and radius  $OA = 1$ . Draw the diameters  $AA'$  and  $BB'$ , at right angles. With centres on the diameter  $BB'$

draw two circles, each having a radius of half that of the original circle. From point  $A$  swing an arc  $NM$  which is tangent to the circumferences of the two inner circles. Repeat from point  $A'$ . Construct square  $ACB'O$  from the radius  $OA$  of the original circle.

As shown by the arc of the semi-diagonal of this square, the radius  $AE$  of the arc  $NEM$  is  $\phi$ , and the arcs  $NEM$  and  $NDM$  divide the radii  $AO$  and  $A'O$  into the Golden Division of  $1/\phi$  and  $1/\phi^2$ .

A curious paradox arises when we divide a unitary circle in two in this manner, forming the basis for the traditional yin-yang symbol. The two circumferences of the inner circles are together

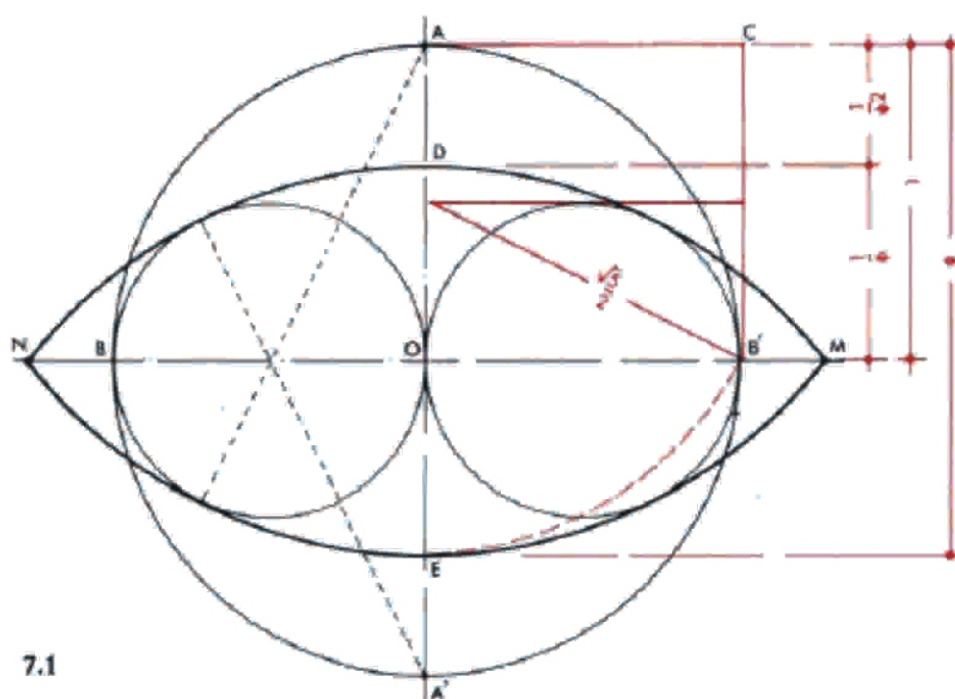

equal to that of the larger circle, but the area contained within the two is only half that of the original circle. One has become Two. Both Hindu mythology and medieval European alchemy give us the same metaphor to contemplate this mystery of a homogeneous unity which becomes a polarized duality: When homogenized or thoroughly stirred milk is left to stand in a moderate temperature it will enter into an acidic fermentation which coagulates the milk into the contracted, fatty globules of curd which float in the watery whey. We have then a separation of mutually repellent forms which arise from a common source. Mythologically this natural process is figured in Cain and Abel, Seth and Horus, Indra and the Asuras, etc., the universal, antagonistic and oppositional interaction which forms life: this is yin and yang.

When we form geometrically the container of the two circles by drawing an arc from each end of the vertical diameter tangential to the two circles, terminating both the upper and lower arcs at the horizontal diameter, we see that these two arcs have cut the vertical radius OA (regarded as 1 or unity) into the Golden Section of  $1/\phi$  and  $1/\phi^2$ . The Golden Mean as the primary division of Unity is here analogous to the invisible provocator, the universal contractive or coagulating power. It is also evident that the radius of this arc equals  $1 + 1/\phi$ , which is  $\phi$ .

The vesica enclosing the primary duality (similar to the Vesica Piscis of Workbook 2, but of different proportions), is found everywhere in Egypt as the symbol of Rê, the solar, life-giving force, the emanating Word, the mouth which speaks the names of the gods, the fractions. The mouth of Rê also resembles the moving shape around a vibrating string (see p. 22).

Drawing 7.2. The arc of Rê which lies tangent to the two inner circles cuts the outer unity circle at exactly the point which gives the side of a regular pentagon inscribed in the outer circle, measured from the upper extreme end of the vertical diameter to the left at J and to the right at F. In addition, by placing the compass on the lower extreme of the vertical diameter and drawing an arc tangential to the near curve of the twin circles, we can obtain the exact length of a third side of the same inscribed pentagon touching the outer circle to the left at H and to the right at G. Then, by simply connecting the two upper ends of the pentagon to each end of the base side, we form a perfect inscribed pentagon.

Thus, given with the original scission or contraction into two is the plan of the return: the pentagon, the symbol of life, with its fivefold symmetry which appears only in living organisms. This is the figure ascribed to the physical and vital aspects of man, who, through the five senses, perceives the natural world and thus brings it into existence. The star pentagram formed by the diagonals within the pentagon symbolizes transformed or perfected humanity, because all the line segments of the star pentagram are derived from the Golden Proportion (see p. 52).

Therefore the initial division, which simultaneously gives the proportions for the fivefold symmetry, carries with it a teleological message which is that of Life as the force of levity and return toward the light, as we see in plants which grow back toward the radiant energy source which they embody. This uplifting is given geometrically at the instant creation begins, when One becomes Two. Now that this principle is invoked in our geometric metaphor of creation, we can proceed with the symbolic squaring.

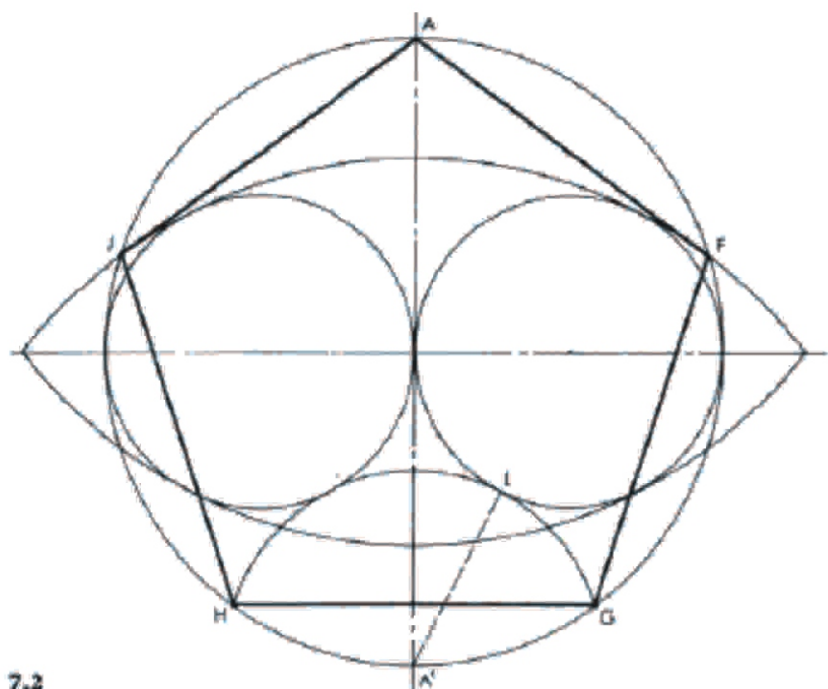





sound: the music of the brook; the crickets with their incessant controversy - "Katy did! Katy didn't!"; the bright, clear whistle of the red bird; the trill of the lark; and the soft, sad cooing of a dove in the distance; all seemed to blend with the rustle of the proud, new leaves of the maples, oaks and poplars as they swayed in the caressing breeze.

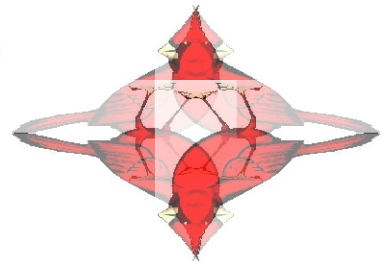

'Sound: the music of the brook;' - the interactive harmonic resonant frequency of the Aether. Sound also represents magnetic field. The 'crickets' or never ending pulsation of the 'C' shaped magnets, 'the bright, clear whistle' or invisible harmonic breath or Aetheric field lines from the accumulator. The reference to the 'maples, oaks and poplars' is a reference to the geometry of the inner rotating assembly passing through the 'caressing breeze' or the magnetic field they revolve in due to the field created via the exterior rotating assemblies 'C' shaped magnets. Considering this passage relates to 'sound' and basically describes the natural harmonic resonance surrounding a stream in the heart of a forest, it is a direct relationship to the Aetheric vortex flow beginning above and below (as above, so below) each cone of the central accumulator continuing on an ever evolving path of compression and expansion with the field being held and dispersed from the geometric poles correlating at the Mica dielectric equatorial field correlator. The fields of the central accumulator travel onward creating the harmony and resonance among the inner working components of the craft, as per the inner workings of all nature.

\*\*\*\*\*  
 One who loves nature and its music may listen

only to the overtones and ignore the chords and discords that also abound. The close observer, amongst all this beauty, sees a spider, perched on top of a fallen leaf, waiting to pounce upon and instantly devour some poor bug that is crawling underneath the same! A black snake, coiled 'round the limb of a tree, lowers his head and, with forked tongue wickedly darting in and out, prepares to strike an unsuspecting timid bird!

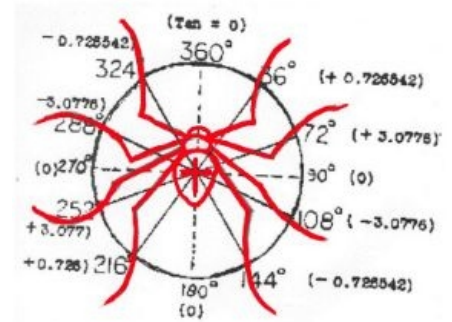

The previous passage describing the harmonies of the inner workings constitute the microcosm in the macrocosm.

A drawing of a Red Black snake coiled on the ground. A snake found in Australia. Black on top and red underneath.

If we look at the drawing below and visualize the points 'A' and 'B' as the points where two tree branches protrude, this drawing is now a 'side elevation' and not a 'top elevation' as in the previous drawing.

If we now overlap points 'A' and 'B' we see the points 'C' and 'D' forming the shell of the cosmic egg holding the 'unsuspecting timid bird'.

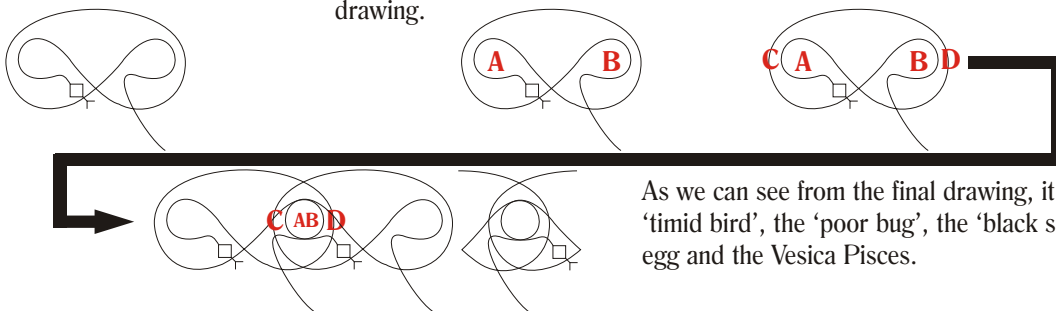

As we can see from the final drawing, it encapsulates the 'timid bird', the 'poor bug', the 'black snake' the cosmic egg and the Vesica Pisces.



The significance of the 'bug' to the project at hand is quite profound. The 'bug' or 'Kheperu' or scarab beetle I have drawn here is the final piece of the craft circuitry and the control method by which the craft is maneuvered. The cartouches drawn here are two of Amenn Tutankh Haqansu, better known to most as Tutankh Amun. We will look at the second one now. Kheperu, the scarab beetle, is the embodiment of the zero point energy space craft which is the Human body. The upper surface being composed of three part. The head or front representing the seven orifices of the face (eyes x 2, ears x 2, nose x 2, mouth) and the two halves of the back or shell representing the left and right hemispheres of the brain. The under side of the scarab beetle displays the tree of life and energy chakra points the Human self. The entire cartouche of Ra Kheperu An Neb displays the principal of the pilot interaction and control of the craft. This is the so - called 'LASER' illumination system for the crystal ball in the center of the craft. Neb - represents the rear mirror, An - the plurality of the harmonic interactive Aetheric field to be viewed, Kheperu - conscious interaction with the pilot, Ra - the output coupler, crystal ball, as the name suggests the dispersal of rays.

A black snake,  
coiled 'round the limb of a tree, lowers his head and,  
with forked tongue wickedly darting in and out, prepares  
to strike an unsuspecting timid bird!

These, and like happenings, are the undertones in  
the forest symphony lest anyone forget, in this mortal world  
of sin, that where there is beauty, there is also pain!

And so, in this particular woodland, on this par-  
ticular day, from nowhere it seemed, a heavy, dark cloud  
appeared overhead; and where before all was brightness and  
sound, deep shadows abounded and all live sounds ceased  
abruptly.

Life in the valley prepared for a summer shower;

3

'A black snake, coiled 'round the limb of a tree', the above is a VERY significant passage. The 'black snake' represents the raising of the Kundalini serpents, yes plural. This one specific snake represents both polarities of the Kundalini energy. The 'black snake' or 'red belly black snake' is black on top and as the name suggests red underneath. 'The limb of a tree' is the eternal tree of life or chakra system of the body. As the pilot raises the serpent energy of the body (increases the resonant frequency of the body) it begins activating the chakra system of the body which is the process of 'turning on' the energy vortex system of the body. The picture below displays quite clearly the 'timid bird'.



The 'timid bird' represents the third eye or pineal gland. When you understand the process of activation, the lowering of the snakes head ready to strike is the point just before the pineal gland is opened. As this vortex fully activates and opens up, it is at this point when the serpents 'strike' the pineal as they have each chakra vortex on there progression from the feet upwards. As the eternal light enters through the top of the head it floods the body from the feet upward unifying all energy vortices of the compressed energy structure known as the Human body. The wings represent the fact that through the activation of the entire chakra system, the pineal gland is mankind's connection to the totality of all creation. This energy activation is the final stage of enlightenment in the process of reawakening the physical angel we all are. When this is realized and achieved, the knowing that all matter in existence is energy in varying degrees of expansion and compression, is the actuality in which you reside. By this means of conscious knowing you may be anything from pure energy to the smallest particle to the largest universe and anything and everything in between. The process of activation is the realization of the ultimate pure balance of the masculine and feminine energies. GOD consciousness is being the pure balance. 'These, and the like happenings, are the undertones in the forest symphony lest anyone forget', without the undertones one can not experience the overtones. Symbiosis. 'In this mortal world of sin', 'In this finite world of ignorance to the true path of divine existence', Failure to realize the understanding of the kinship of all things and there harmony will lead to undesired results. At this point in the progression of events in this particular geometric arrangement of sympathetic harmonic vibrations, the 'dark cloud' or accumulation and compression of Orgone or Aetheric energy is culminating to a focal point of conscious interaction.



Fig. 1 is a clock spring wound up tight, to exemplify concentration.

Fig. 2. Same spring unwound to exemplify decentration.



Fig. 3

Fig. 3 & 4 represents water concentrated into a drop and decentered into vapor.

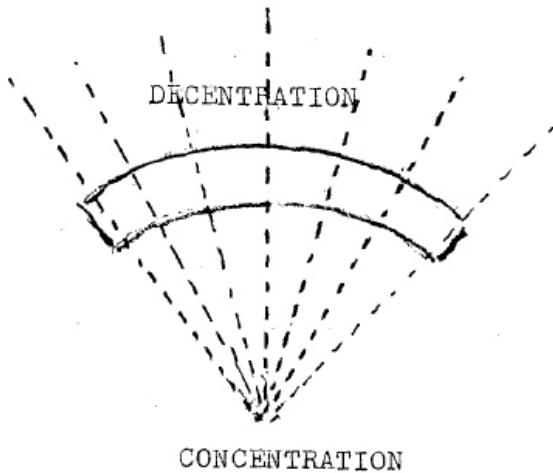

Fig. 5.

Fig. 5 represents concentration of light rays to a point. Light rays thus concentrated through a lens will burn a hole through paper or fabrics.

Light rays proceeding in the opposite direction will expand and cool by decentering toward space.

"The whole physical universe of forming growing bodies is due to the fast motion of concentrative thinking. Conversely all degenerating and decaying bodies are due to the expansion of decentrative thinking."

#### CONCLUSION

I hope you can all clearly see that the only desire you should ever have is the desire to acquire God-awareness in you for the purpose of extending God's nature from you as your

UNIVERSAL LAW, NATURAL SCIENCE AND PHILOSOPHY Page 63

nature, His power as your power, and His knowing as your knowing. Meditation is for the purpose of acquiring this awareness. And if you acquired it just for the bliss of it, for the ecstasy and peace of it for yourself alone that is not enough, for the God nature is purposeful and you must be purposeful by extending your nature to all other men for their cultural uplift.

Life in the valley prepared for a summer shower;  
and a bolt of lightning with its thunder, like the cymbal  
crash to an overture, brought forth a harvest of rain -  
nature's champagne toast to its myriad subjects!

'Life in the valley prepared for a summer shower;', the valley resides between the 'two mountains' or the two halves of the accumulator, the resonance chamber is preparing for a new burst of Aetheric energy. The 'bolt of lightning with its thunder' displaying the scale of Aetheric static accumulation with its symbiotic twin, the 'thunder' or resonant harmonic frequency. 'The cymbal crash' is displaying the significance of the process taking place as well as the point of initiation in a sequence sympathetic harmonic vibrations when the flow of energy through the circuit is created. The 'harvest of rain' is the mass accumulation and distribution of the Aetheric energy flow through the central accumulator and on ward as a result of the resonant frequency created within each and every part and therefore subsequent process occurring in the ecosystem of the craft, this includes the pilots.

At this point it must be pointed out the process of teleportation. The crystal is a conduit for the interaction between pilot and Aether. The process is: focus, the vortex begins,  $10^{12}$  hertz frequency is reached through counter rotating vortex, matter is transmuted to light, you are now where you wanted to be, the frequency of the vortex instantly slows down compressing light into matter, done.

The dancing brook, joyously responding to its  
replenishing toast, was sitting out its intermission in  
the form of a deep pool whose quiet depth was shaded by  
the foliage of a stately maple.

And a large, maple leaf on the end twig of an  
extending branch a few feet in the air above the pool, is  
the complete stage, setting, scenery and props for the lit-  
tle drama which will soon unfold.

'The dancing brook' or accumulation of field energy is consciously resonating with the new and ongoing accumulation of vortex field energy. The 'deep pool' displays the fact that just like fresh cold water stored in a deep pool, this is not an evaporating form of energy storage. The deep pool is a quiet everlasting store of clean fresh accumulated energy. The 'stately maple' the geometrical arrangement of the vortex energy interaction with the accumulator.

This ecosystem (or stage) of harmonies, sympathetic resonant frequencies and vibrations (or setting) is a result of the sacred arrangement of creation geometry (or scenery) and the resultant sacred geometric structures and components (or props) of the craft.

The shower ended as quickly as it began. The bright rays of sunshine, with its many refractions from the moistened foliage, made the forest a treasureland of glittering gems! The beautiful spectrum of a rainbow appeared in the sky over the valley where moments before a dark cloud had been.

'The shower ended as quickly as it began', the whole process from initiation of the sequence of events through to conscious interaction with the craft happens instantaneously. The accumulation and compression of the Aetheric energy and the subsequent release or expansion. This is the final transmutation of the Aetheric energy spectrum into visible light through the 'moistened foliage'. The 'moistened foliage' holds raindrops. The raindrops, are relationships to light refraction. This is the process by which the Aetheric field is viewed in the control cab via a crystal ball producing 'The beautiful spectrum of a rainbow' in the control cab directly above the center of the craft. This is the means by which the interactive sympathetic harmonic resonant frequencies of the Aethers are manifest in the visual spectrum. These interactive Aetheric frequencies are the octave frequencies of all sacred creation geometry and the means by which the manipulation of energy into matter and matter into energy occurs.

Again the gay life sounds of the woodland broke forth in a multiplicity of vibrations in higher pitch and more abundant than before the shower. At this moment, one who has sensitive eyes and ears for beauty can become temporarily transfixed with the spellboundment of it all!

As soon as the sequence of initiation of interaction with this field is focused upon by projecting the frequency you wish to go to from your mind's eye or pineal gland to the crystal ball in the control cab, a process of sympathetic resonance is established amongst the inner workings of the craft in order to allow the entire craft and occupants of the craft to consciously change their resonant frequency in order to cease residing in the frequency they are in where they enter the craft and subsequently now reside in the location corresponding to the frequency they previously projected. As this projection is occurring from the spiritual mind at higher dimensional frequencies than the three dimensional brain can comprehend, the three dimensional thought process may try bringing third dimensional rationality in and try confusing the situation. Block this out.

A cocky bluejay (policeman of the bird world), who had been disgustedly trying to shelter under the large, friendly leaf of a tall poplar, emerged and resumed his fun of harassing a pair of nest-building wrens.

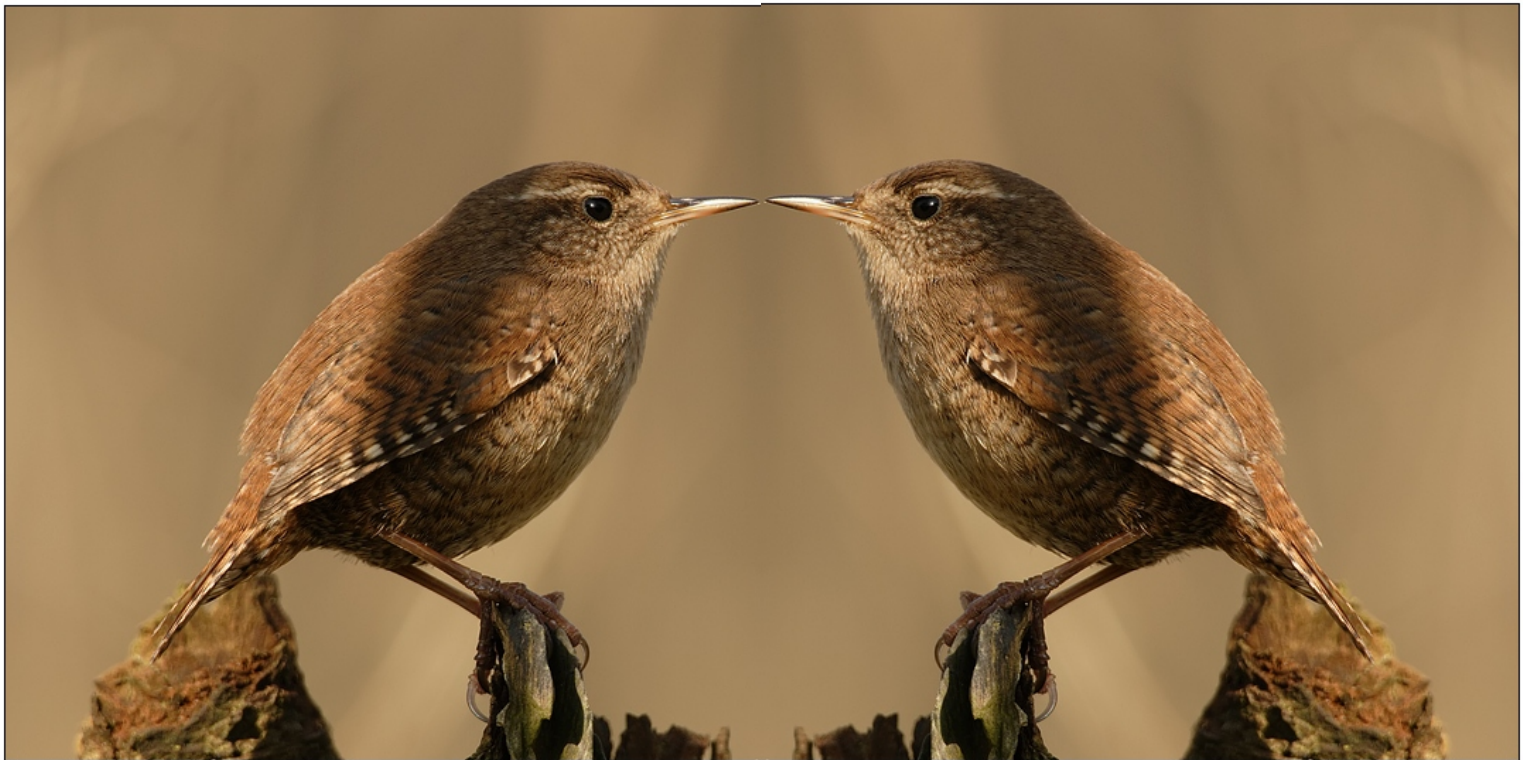
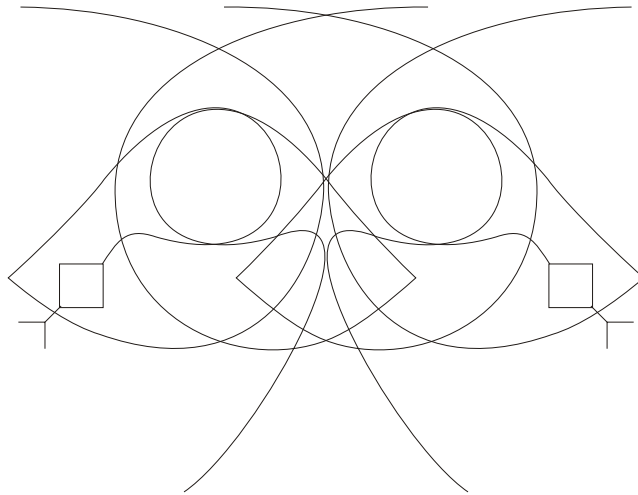

Zaunkönig / Winter Wren (Troglodytes troglodytes)

(αὐτὸβόλοισι αὐτὸβόλοισι) ἡρῶ ἡρῶν ἰ γινώσκουσ

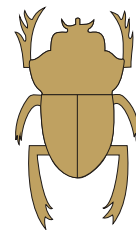
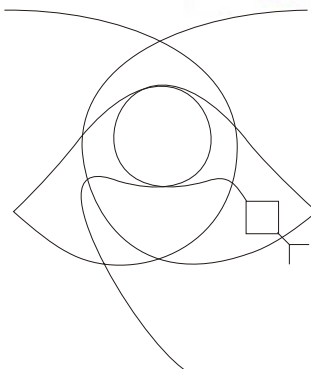
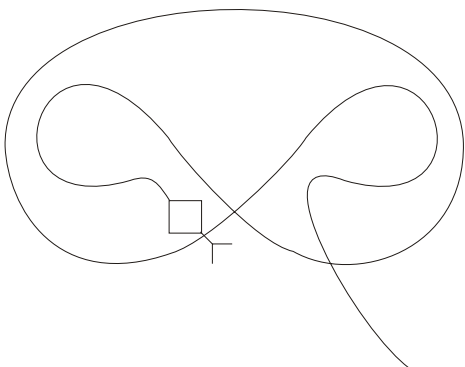
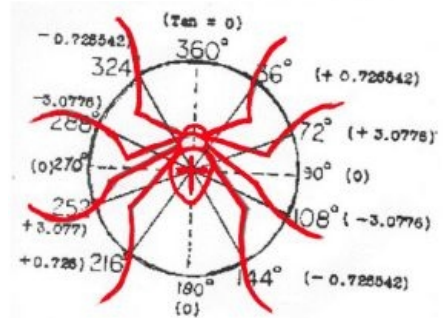
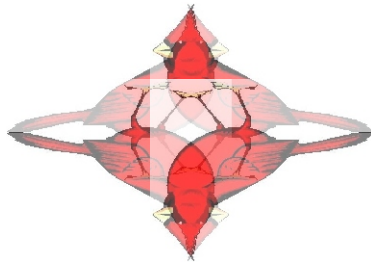

Along the banks of the brook and into the forest, one could hear the gentle drip drip of the lingering raindrops that were bidding adieu to their hosts, the leaves, as they rejoined their multitude in the swift, little mountain stream below.

'Along the banks of the brook', brook = small stream, the neutral center holding the flow of Aetheric energy. The name 'neutral center' refers to the point where the field pressure is greatest, even pressure each side. One can understand from the above passage the cyclic flow of the Aetheric energy. With the sacred creation geometry of the accumulator there is a continuous flow of Aetheric energy interacting with the shape of the design. This flow begins as the Aethers. The Aether interacts with all matter, this is true, though the Aether accumulates in specific areas of geometry and organic material. This process is ongoing in the structure of the craft, whether it is in operation or not, due to the fact that the entire craft is a sacred geometric arrangement of sacred geometric arrangements. Therefore the process of Aether interacting with the geometry creates static which is continuously accumulated and stored as field potential. By this manner the craft remains consciously and continuously charged and ready to operate at any time, no need to refuel.

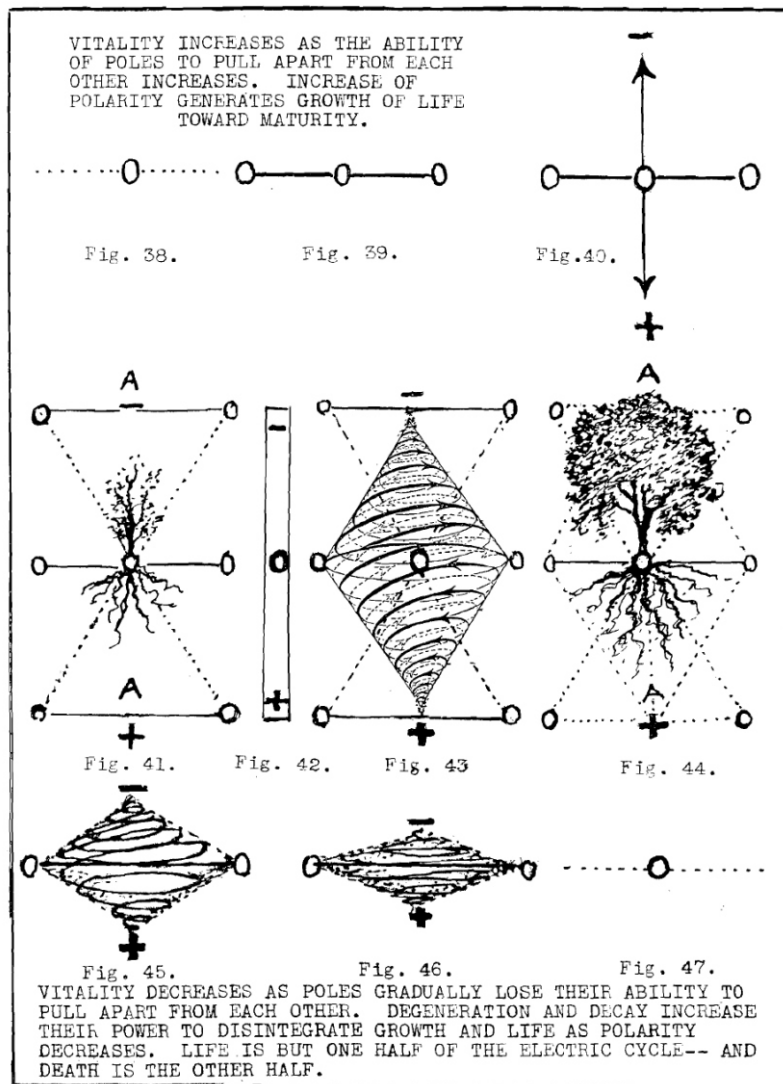

We now return to the aforementioned maple leaf extending proudly over the pool. On this leaf, there were two, little drops of rain who had not as yet rejoined their brothers and sisters in the gay currents of little Jordan.

In the vortices fields of the central accumulator the natural progression of energy is one of continuous compression and expansion, this is where the 'drops of rain' or Aetheric energy resides in the form of an everlasting vortex which figuratively resides as a mountain with the trees extending either side of their neutral point or neutral center or the Earth they are planted in, which is the neutral center. As the root system of a tree mimics the vortex shape of the branch and leaf structure, you can understand the vortex interaction with the central accumulator as each half (or presto conical section) is a mirror of one another displaying the entire geometry of all creation. This passage allows you to understand the progression of events within the vortex field of energy. 'Jordan' is a reference to the octave waves of vibrating light which constitute the elements of matter. Matter is manipulated by sympathetic resonant frequency. The Sol Feggio scale is the perfect circle of sound found in the bible. Below is a beautiful chalk board drawing of octave mathematics.

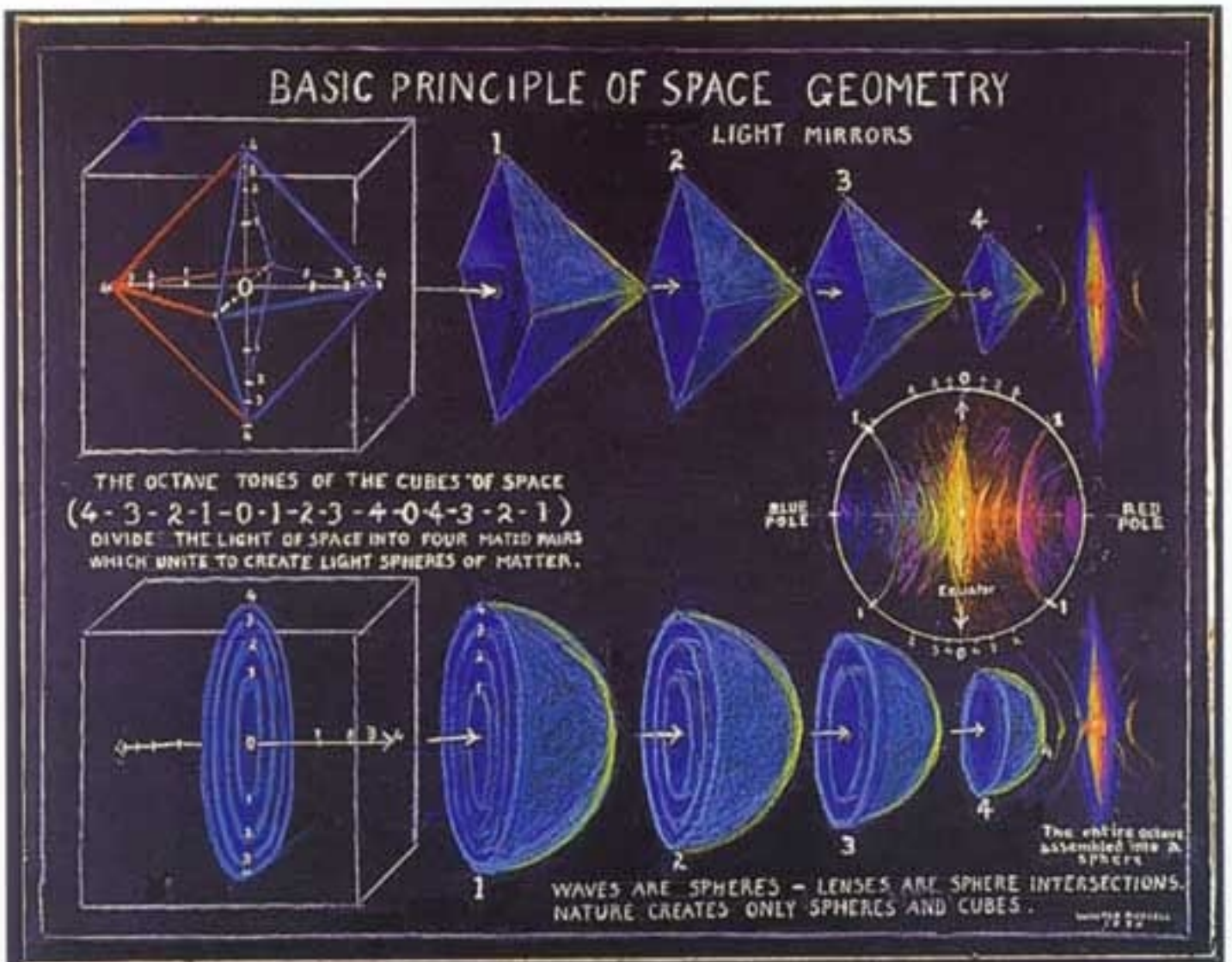

Walter Russell: Basic Principles Of Space Geometry



CHART 1 of 2: MOLECULAR WAVE MECHANICS > CYCLE PATTERNS > IN EXISTENCE, MANY FACETS

thinking

CHART GRAPH (see two pages)  
MOLECULAR-MECHANICS, WAVE FUNCTION

SIXTEN, MANY FACETS OF ONE BASE WAVE CYCLE PATTERN

HEXAGONAL POLYTOPE CHIP MATCHED-SET 180° SPIRAL

VERTICAL WAVE FUNCTION MULTI-CIRCLE OF FITTING COPLANAR WAVE LENGTHS

U.S.A. CHIP QUIDS IS LAYER PLANES  
HEXAGONAL-ALGEBRAIC, CLOCK PACKED  
INVERSION (L.H. to R.H. - L.H.)  
MATCHING OF CHROMOSOMES.

**in Space**

SEE (EXHIBIT 14) 174F CONTROL PANEL UNIT

EGG SHELL

SPHERE

HEXAGON FULCRUM

SPHERE

HEXAGON

MOLECULAR BONDING ARE THE SPINDS OF INDIVIDUAL ATOMS - THEY SPINNING ON A POLE OF REGULAR MAGNETIC FIELD - THE MAGNETIC FIELD ARE SPIRALING INTO THEM BY INVERTING - MATCH

WAVE BAND IS AS BOTH MATTER WAVES FORMS A WAVE OF FILM PLANNING IN THE SAME DIRECTION - SUCH PERMITS THE FILM ATOM FIELD TO FLOW ACROSS BAND BAND

GRAPE KEY CREATION - The ATOM polarization, seen under electron scope (R. Trues) in a kaleidoscope of COLOR - multi - play

Walter Russell: Molecular Wave Mechanics

The stage is set; the curtain rises; and the play is ready to begin!

It is the firm opinion of this narrator that everything created by God must have a portion of His Soul. Forthwith, we endow these two, little, lingering raindrops with segments of the soul of God and give them personalities. This being a romance, they must naturally be girl and boy; and we name them Suzanne and Robert.

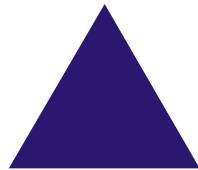

Adam

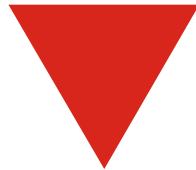

Eve

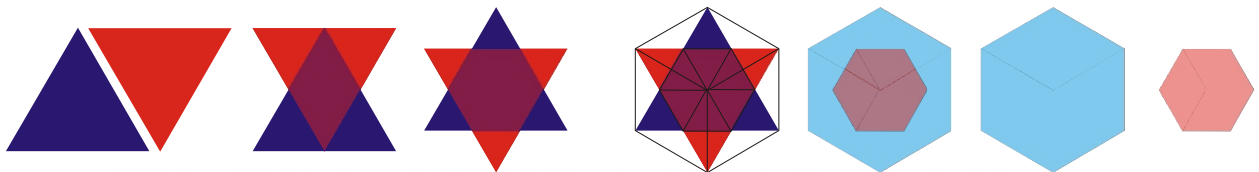
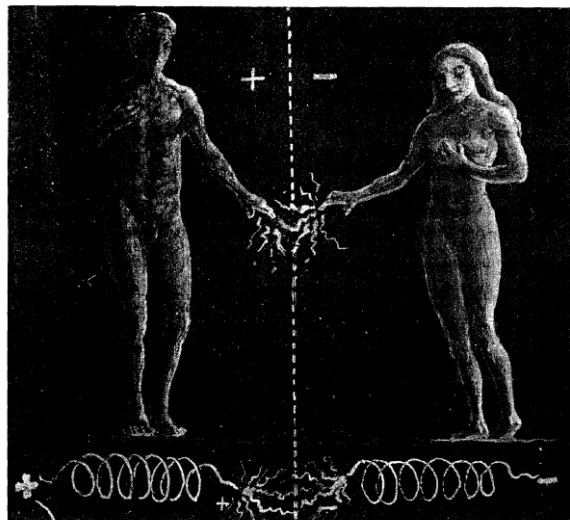

Each were in the ages of maturity; and we describe the young lady, Suzanne, first. Her soul was as pure and her mind as innocent as a spotted fawn sniffing for the first time the rare fragrance of the new blossoms of the wild mountain laurel!

And wherever princess fairies gather in the forest, surely there will be one there named Suzanne!

The passage above is showing the ABSOLUTE BALANCE of purity in conscious God Creation. This is the power laying dormant in the right hemisphere of the brain. The sub - conscious mind. If you picture in your mind the act of an 'innocent' 'spotted fawn sniffing for the first time the rare fragrance of the new blossoms of the wild mountain laurel' you can see absolutely the purity of the intension needed to be held in order to interact with the Aetheric energy field.

The next time you are in the forest and close to a mountain where echoes are wont to be, softly call "Suzanne, Suzanne;" and you will understand.

Her hair was the color and sheen of cornsilk from an Indiana farm; and every gesture and motion of her beautiful body was sheer poetry! The graceful mannerisms of ages gone by were inherited by this modern maid who, innocently and without airs, treated everyone as equal. Haughtiness was not in her nature! Surely her heart was as big as a watermelon, seeds and all!

This simple poet has not the words to describe her lovely, brown eyes - eyes that seemed to mirror the wisdom of women down through the ages. Yet, filled with laughter and gayety as they were, one who looked deeply could find a hint of sadness.

Stop! Words fail. Mona Lisa, move over with your smile. The brown eyes of Suzanne, with their mystical beauty, have brought you competition!

The importance of balance and purity once again shown. The description is very detailed towards the innocence and purity of balance. 'The graceful mannerisms of ages gone by' are the sacred balances of art and knowledge held within her beauty. When one studies the art of great philosophers such as Leonardo, you can see almost in an instant there is something other than aesthetic beauty to his artistic creations. It is most helpful to understand how sacred geometry is used in art. If you study the great artists, especially those who dealt with anatomical artwork such as Leonardo, you will soon realize they contain the sacred creation ratios for the geometry of the human body. On the next page are some examples of these artworks painted by Leonardo of Vinci.



‘Annunciation’

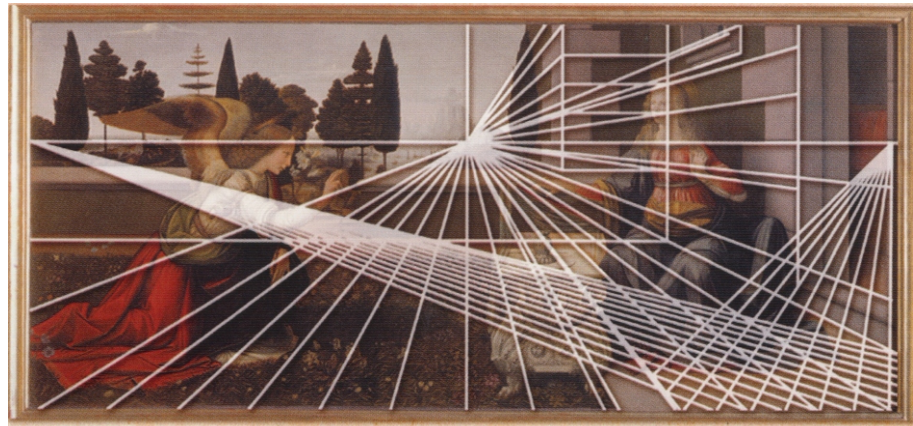

‘Mona Lisa’

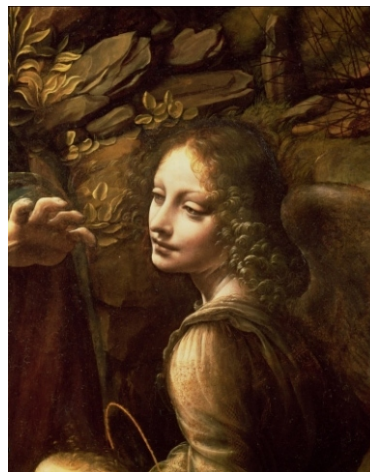

‘Virgin of the rocks’



‘Cecilia Gallerani’



‘Madonna of the Yarnwinder’



‘Munich Madonna’



‘Benois Madonna’

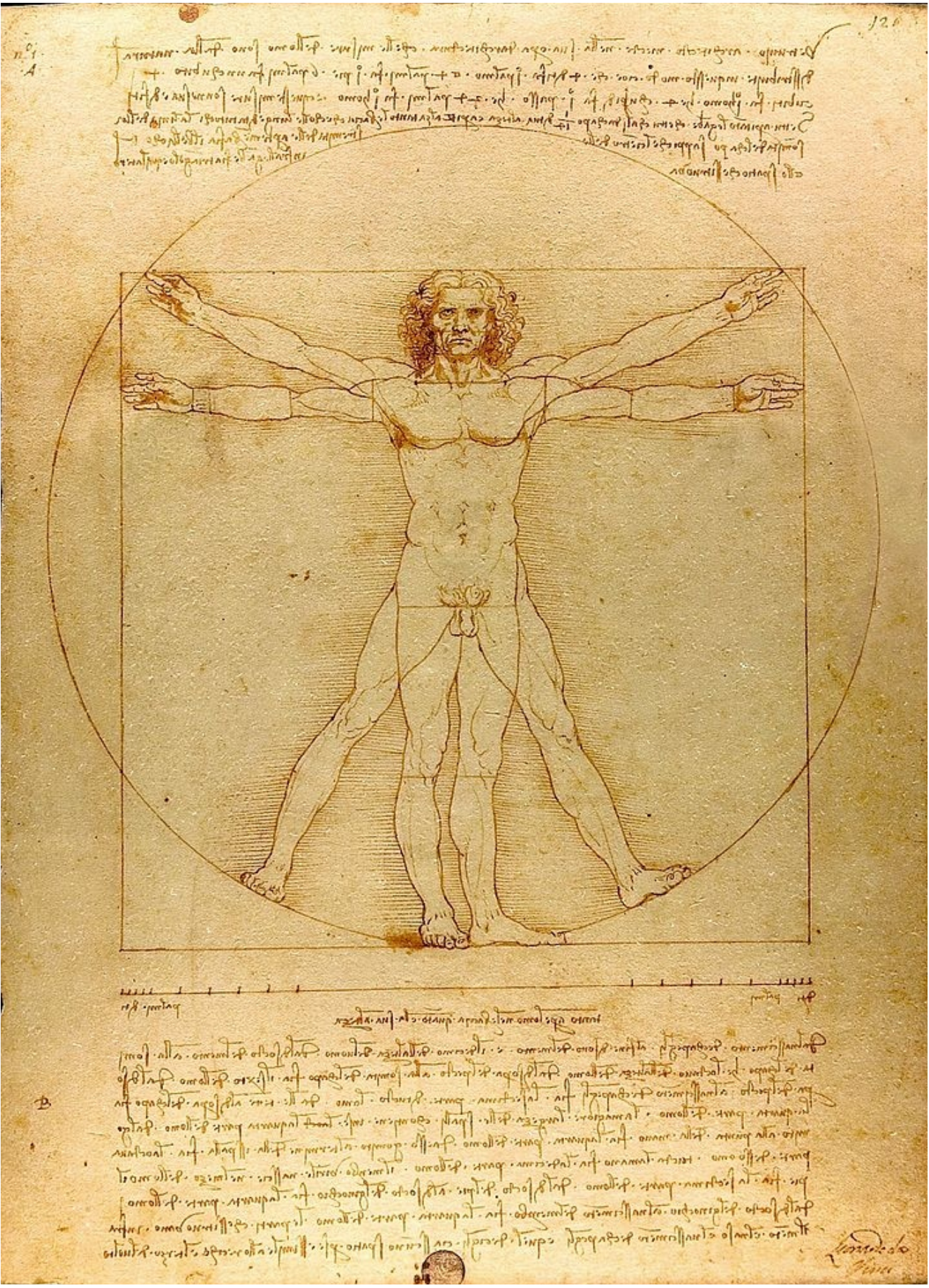

The Vitruvian Man drawn from his observations of the work of Vitruvius by the great Leonardo of Vinci.

After what has been said, is it any wonder that the boy raindrop, Robert, worshipped, with unselfish love, his companion, Suzanne.

The seeker for rare gems, having found a pearl of great price, for a long time allows its beauty to be enhanced by a background of regal velvet not daring to desecrate such rare loveliness with the grossness of a touch!

'After what has been said' this displays the nature of 'Robert', or the masculine and the conscious control of the patriarchal left hemisphere of the brain. The masculine left hemisphere of the brain is the basis of dominance and unbalanced control in the body therefore the state of all things associated with the body. When one masters thine own self, when mankind be as one, only then may a progression of the same follow throughout all existence. This also relates back to the coiled black snake:

A black snake,  
coiled 'round the limb of a tree, lowers his head and,  
with forked tongue wickedly darting in and out, prepares  
to strike an unsuspecting timid bird!

The 'pearl of great price' the very essence all mankind seeks is encapsulated in this work. This is the substance the ancient alchemists sort, the philosopher sought the stone, so called 'modern' man tries unraveling these mysteries and is lost in the translation, why? The term 'a picture speaks a thousand words' is true. All ancient language, if conveyed three dimensionally was done so via picto - glyph, hieroglyph, painting, drawing or some other form of specific symbol that could not be changed in its meaning so as the knowledge of what it contained was both hidden and preserved. Curiosity of the unknown tends to preserve it for a time when it can be deciphered. The coiled black snake is the helical structure of the DNA and the energy grid and energy points or chakra - endocrine system of the Human self as well as the Kundalini serpent energy contained within. The 'pearl of great price' is Balanced Pure God Consciousness. The true philosopher stone. The raising of the Kundalini serpent and 'cutting off its head'. The balance and understanding of all knowledge. This is the knowledge of how one understands and thereby interacts with, in true conscious totality, all matter and all energies in all creation via the sacred tones of all God's creation and therefore all sacred creation geometry. That is why when you understand language, even a little, you know the 'philosopher's stone' is actually the 'philosopher stone' which is in fact is the 'philosophers tone' or the knowledge of the interactive frequencies of all creation. They are interactive for the simple reason that: you are, just as 'Suzanne' and 'Robert' are, a portion of God's soul. The Eternal Light Of God Consciousness. By this means it is only natural that you, me, we all interact with our environment. It begins with knowing thy self in totality, loving thy self in totality and being the difference you want to see. Your connection with Source, or GOD, is entirely up to you. Being GOD consciousness is the enlightenment leading to ascension. The realization of the physical angel we truly are, with the dissolution of third density matter to the realization of pure energy where the realization of all things is actuality.

There are also relationships in infinity loop windings for coils in the geometry of the coiled black snake.

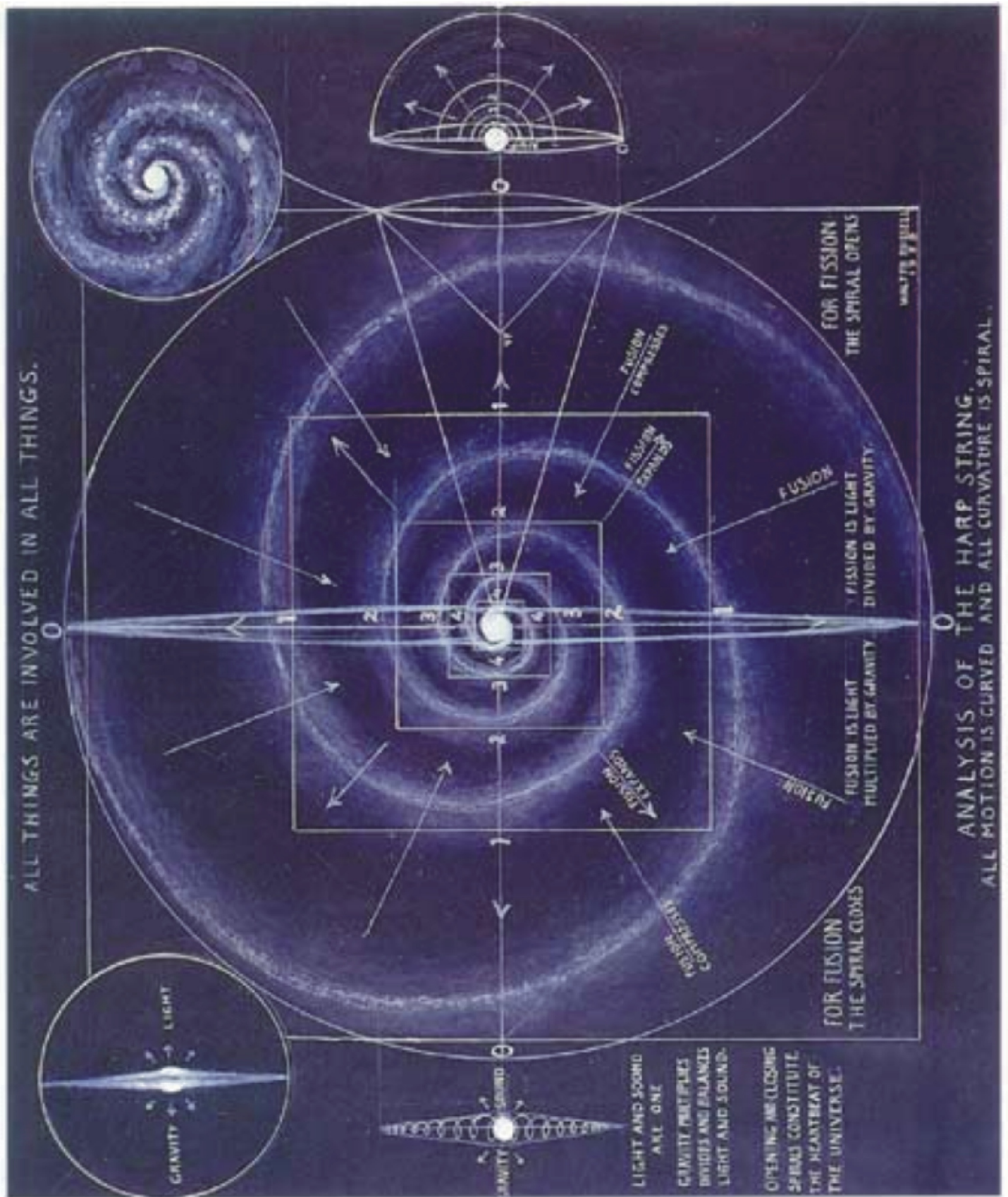
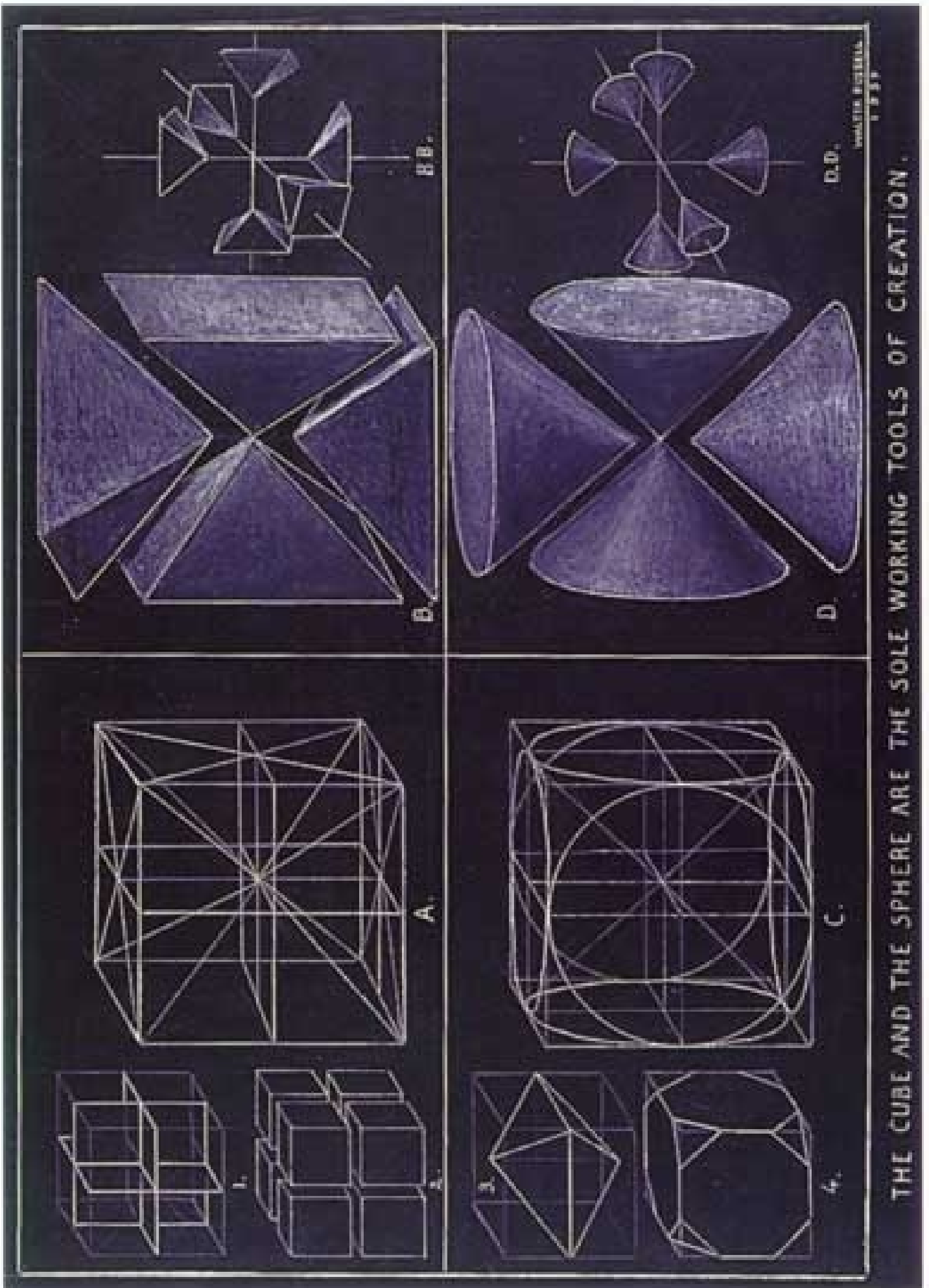

Figure 3

Completed in 1959 and published in *The Home Study Course*, X:770



THE CUBE AND THE SPHERE ARE THE SOLE WORKING TOOLS OF CREATION.

WALTER RUSSELL  
1907



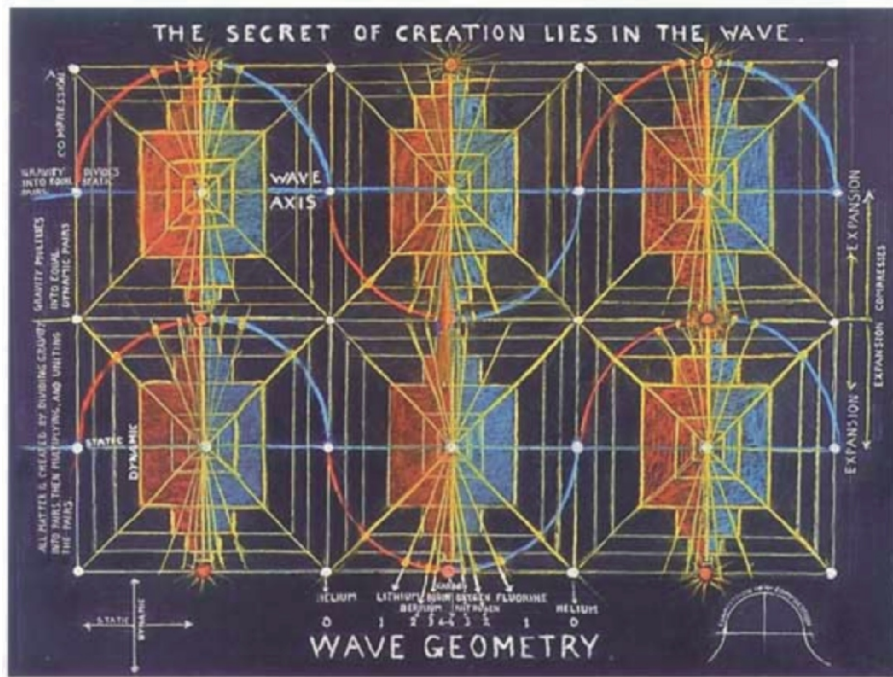

Walter Russell

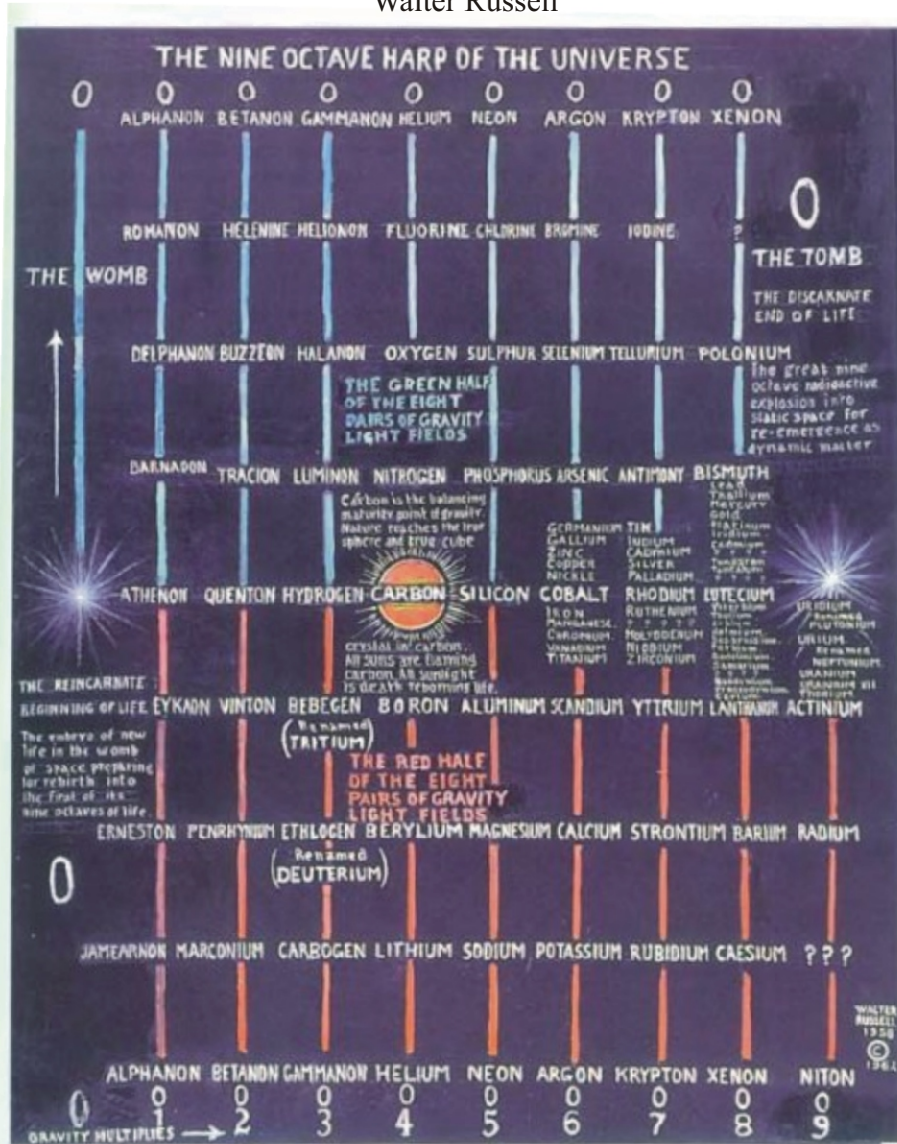

Walter Russell

Reprinted in 1967 and published in *The Home Study Course*, XI, 830.

Time for a quick explanation on the significance of sacred geometry and it's relationship to GOD, more specifically the word 'GOD'. Below is a series of drawings showing the geometric reasoning for the letters 'G', 'O' and 'D'. Intern the significance of geometry is revealed.

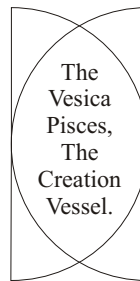
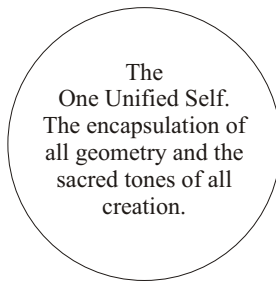
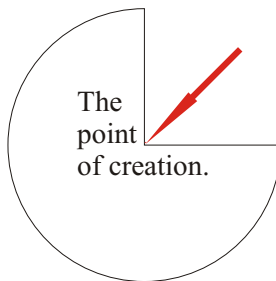
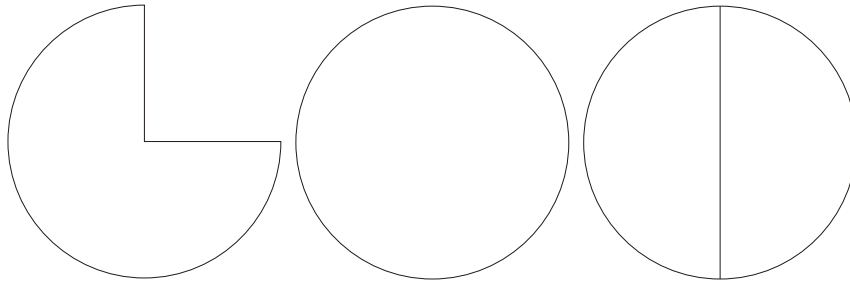
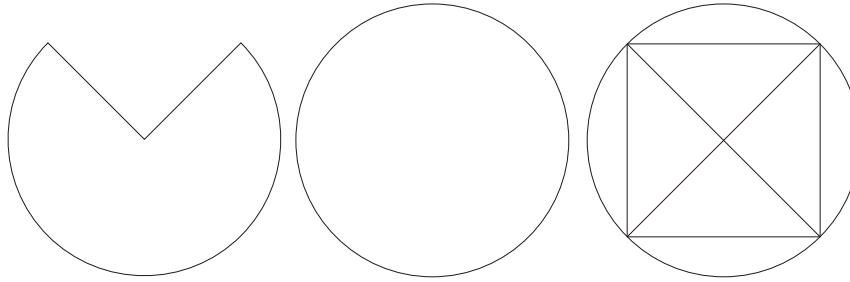
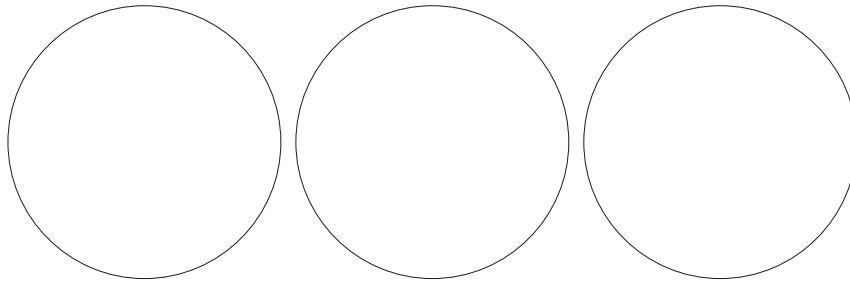

Left hemisphere  
+  
Right hemisphere  
=  
balance.

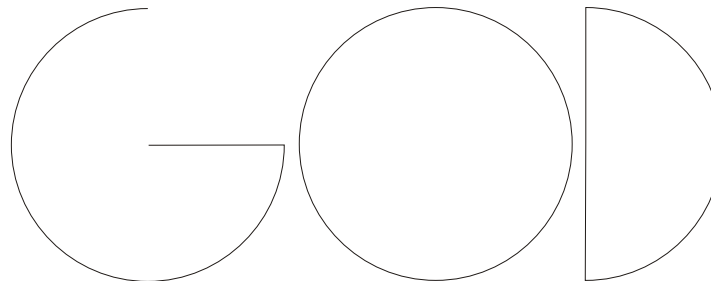

Not so the

profane and uncouth of the world who devour beauty as they find it and give forth as their satisfaction a beastly grunt!

Now, compared to Suzanne, Robert was a very ordinary person indeed. In physical appearance and stature, he was just an average person and no more need be said thusly. However, he did not have an ordinary mind else God would not have allowed him to be in the fine company of the magnificent Suzanne. He had a soul that worshipped beauty; and he could walk into any museum, and, amongst the chit-chat producing nonsense, unerringly locate a Cezanne, a Holbein or a Corot!

Although obscure and unknown by his brethern, the raindrops, he was a true scientist and investigator of nature. He was a true scientist because he knew that the wisdom of God came direct from Him, or His accredited representatives in the cosmic heavens, to those, and only to those, who were worthy.

He loved all life intensely; and to him, the despised bug racing across the floor, homing to its scent with waving antenna, was a poetic interlude. Every rock, upturned in a meadow, held for him a new universe of exploration.

As you might have surmised by now, the inquisitive, nature-loving Robert, having found a vantage point for new observation on the maple leaf, was the reason why he and Suzanne were spotlighted there. With an eloquence bordering

Suzanne, Robert  
a Cezanne, a Holbein or a Corot.

Suzanne, Robert  
a Ce  
zanne, a Ho  
lbein or a  
C  
rot.

Se, Rt, Ce, Ho, C

With an eloquence bordering

rapture, he was explaining to her the colors of the rainbow overhead - how each beautiful hue had a wave length and a personality all its own. And how the blending union of the red with the violet produced the purple magenta which was, in its indescribable beauty, the color and vibration of holiness itself!

## GEOMETRY AND MATHEMATICS OF OCTAVE WAVES

1 The formless zero universe is divided into four pairs of cubes and four pairs of spheres which are concentrically placed within each other. These four pairs of cube-spheres constitute one tonal octave of the universal harp. These tonal octaves are eight in number but appear to be nine for the first half of the ninth octave is the last half of the first. See diagram No.6 below.

2 0-1-2-3-4 0 4-3-2-1-0

THE EIGHT TONES OF AMPLIFIED GRAVITY WHICH ACCUMULATE IN EACH OCTAVE WAVE

3 The explosion of accumulated gravity occurs when the orange-yellow and green-yellow of the color spectrum collide and become "short circuited" by their union with white.

4 Radiactivity multiplies SPEED by losing power.



TWO GROUPS OF WORDS OF SAME MEANING	
1. Gravitation.	Radiation.
Generoactivity.	Radioactivity.
Induction.	Conductivity.
Electric potential.	Explosion.
Compression.	Expansion.
Light.	Darkness.
The "pinch effect."	Short circuit.
Concentrate.	Decentrate.
Growth.	Decay.
Life.	Death.
Appear.	Disappear.

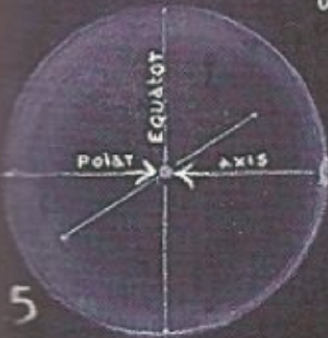

Genoactivity multiplies POWER by losing speed.

9 Gravity explodes radioactively, at an amplification of 143,398,528.

8 Gravity climbs to 16,674,816.

7 - Gravity compression is now 2,088,352.

6 - Gravity reaches 288,544.

5 - Gravity now equals 33,768

4 - Gravity multiplies to a cube power of 4096.

3<sup>rd</sup> octave - Gravity = 512.

2<sup>nd</sup> octave - Gravity power = 64. Wave speed reduces in cube ratio.

1<sup>st</sup> octave begins here with a gravity power of 8.

CREATION ENDS HERE

CREATION BEGINS HERE

Wave speed, 186,400 miles per second.

Walter Russell



From the book, *Osiris and the Egyptian Resurrection* by Sir E. A. Wallis Budge.

There is something that should be kept in mind when understanding ancient texts. They are not simply something to be understood from the accompanying 'texts'. Esoteric information is basically layered encryption. If you look at the picture above you can see circled the chest and arms of 'The goddess of the West receiving into her hands the disk of the setting sun'. As all existence is encapsulated in the circle of life, so to is this picture. If the goddess of the West is receiving then the goddess of the East must be giving. From the point of view of the OTC - XI we are looking at the 'C' shaped magnet with the Utron being 'received' on its orbit through it. Leonardo's *Virtuive Man* below shows the ratios.

Ratios for 'C' shaped magnets

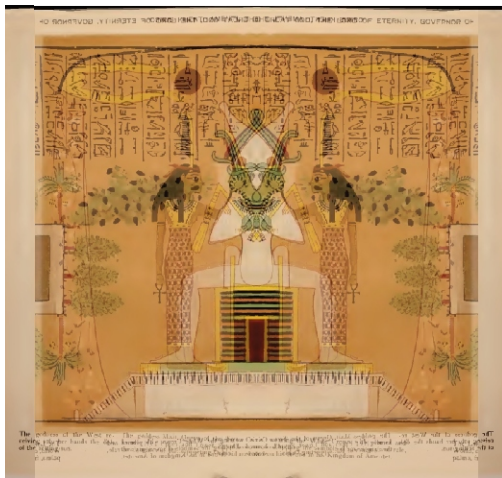

In the overlay (above) Osiris and Maat, notice Maat has her hands on each shoulder and the double figure of Osiris is a perfectly symmetrical. He is also depicted in green and white showing the white light of illumination in alignment with the heart and balance. Maat is truth and balance, with a hand on each shoulder this is displaying left and right hemispheres are in balance. This is a very complex image with many more layers. The energy vortex of the third eye is easily seen.

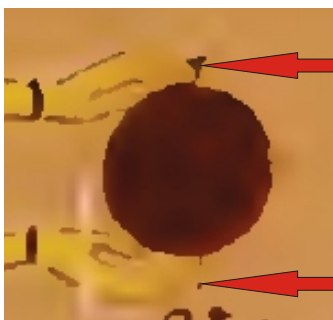
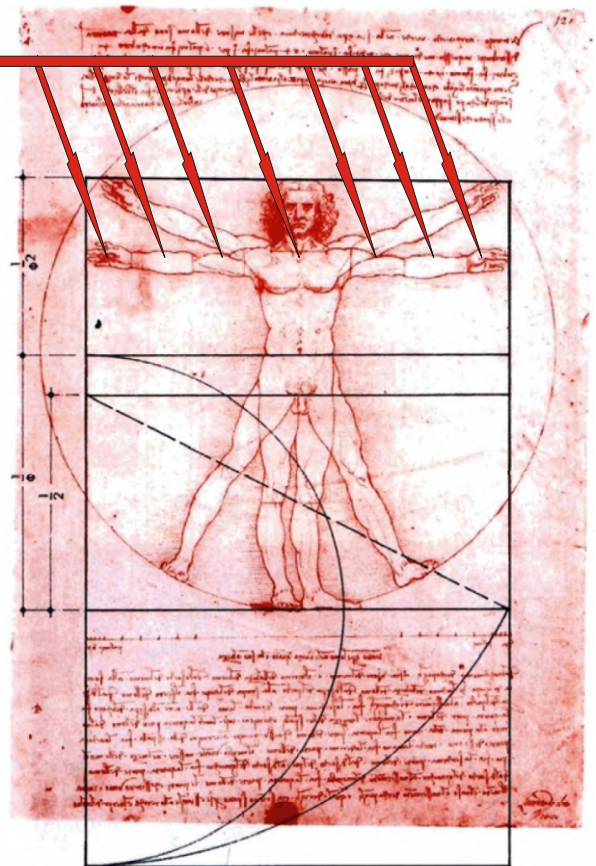

When enlarged it is easy to see actual pivot points above and below the sun disc.

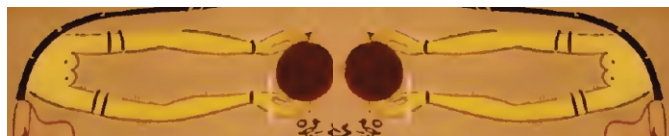

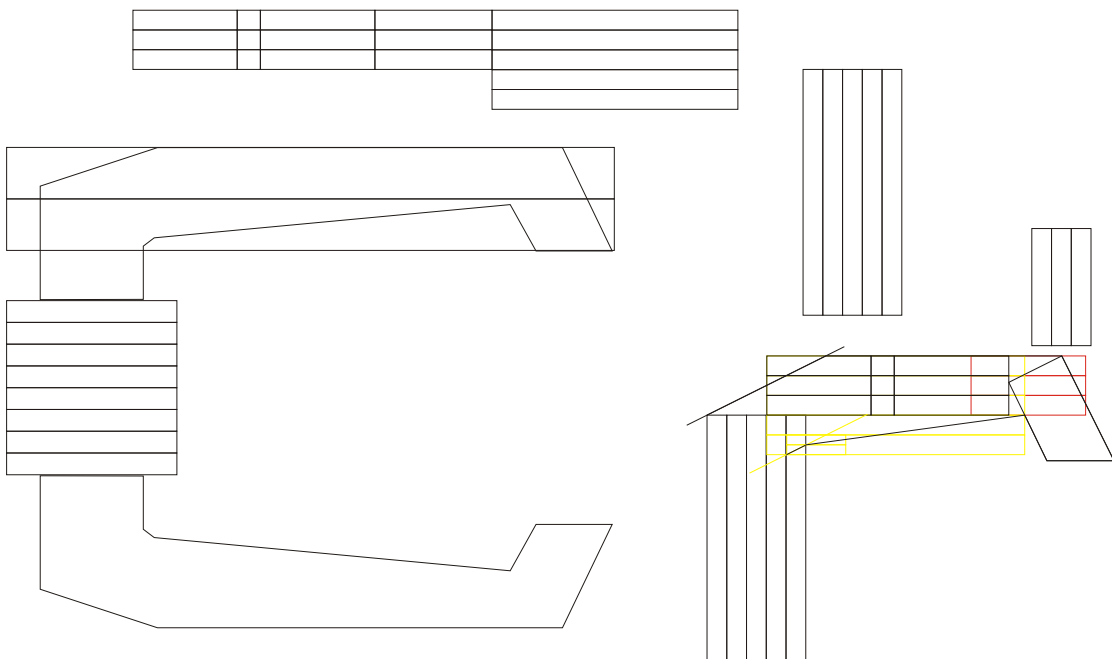
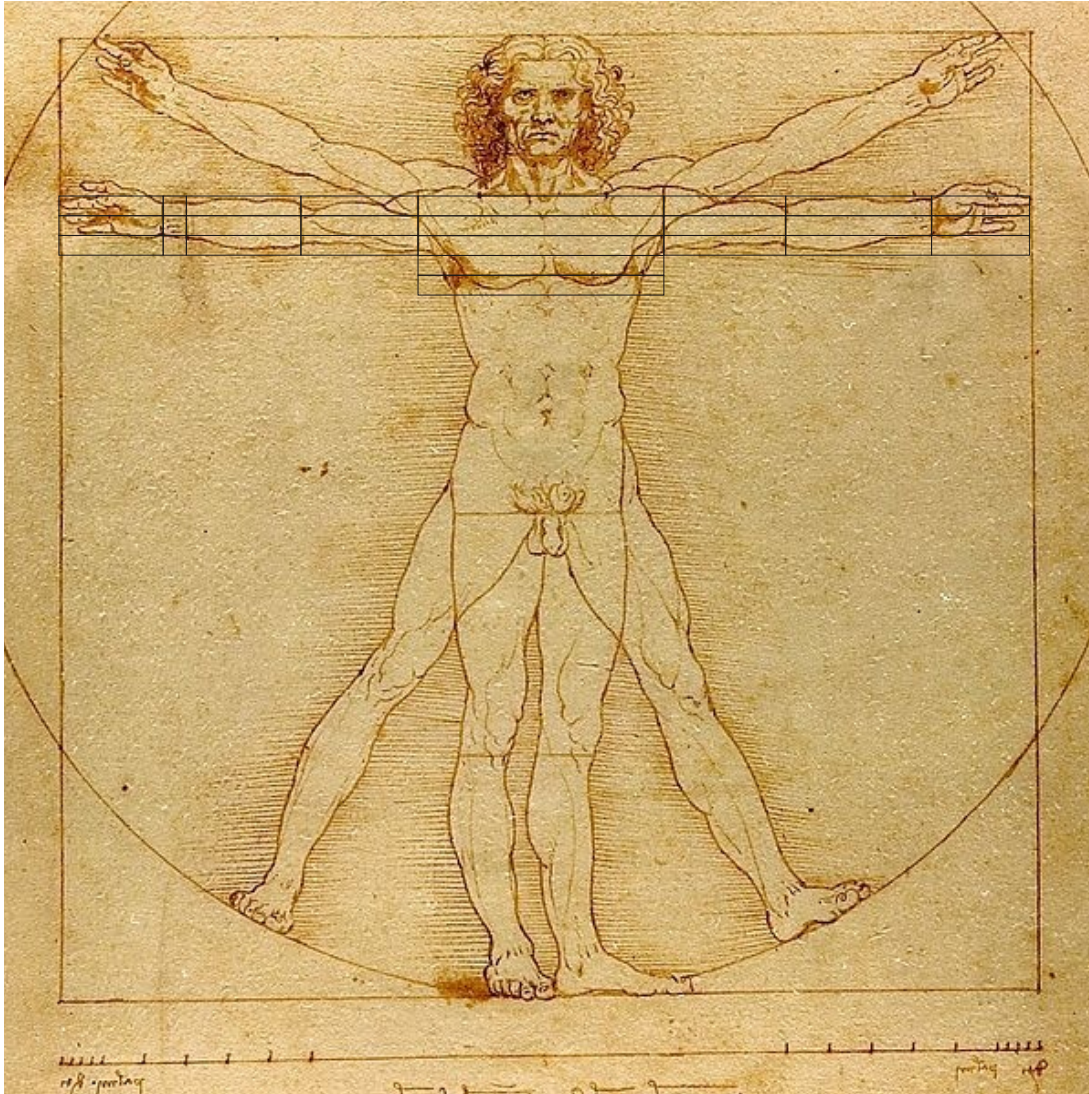

# Concerning the OX Circuit:

Given that Mr Carr was a Temple level Frater of the Rossicrusian Order, one understands this man had not only a deep connection with the hEart (or Earth if you prefer) but also a deep connection with the multiverse.

Mr Carr realized that the universe mimics the multiverse, the galaxy mimics the universe, the solar system mimics the galaxy, the planet mimics the solar system, the human body is the microcosm of the macrocosm, our heart is rhythmically aligned with our planet and considering everything is made of the atom, gravitational energy generators should follow the same principles using sacred geometry. One should also note that Mr Carr had quite a different view of what the actual make up our solar system is. The reason Mr Carr's craft works is because it has no other option. Simply put, as the natural flow of life is that our heart and this planet are aligned and can and do have a huge influence over one another, Mr Carr built a scale working replica of this very planet, that is a craft built to the same dimensions and using the same geometry as all creation and therefore the planet incorporating the use of pure magnetism in the same respect as does Earth and the solar system for an infinite system. Knowing that the human heart brain tissue sends more signals to the brain than the actual brain in your head sends to your heart, all we have to do to control this craft is send the control signal of pure love from the heart to flood the brain so that we can consciously project through the pineal gland the destination. Mr Carr built this as an inter-dimensional teleportation craft, this concept voids time and shows it for the man made conception it is. Both the heart and the pineal gland hold the very magnetic fields in place needed to interact with the energy of the craft. Being a true disciple of the Great Master Adept of the Art, Nikola Tesla, Mr Carr had the most beautiful of mentors. His understanding of the truth is the means by which he had success. Nikola is not Earth bound.

As Otis says "if you want to understand Nikola, you must attune your mind to God".

Here is how it goes:

FORGET THREE DIMENSIONAL THINKING. This design can not be understood in the 3rd dimension. It is commonly understood that this is a counter rotational circular foil craft. This is quite true, however, what is not understood is how it works. The reason for this is we try to conceive the vision of this vehicle as it begins to counter rotate then levitate at auto-rotation and then we go to where ever we are going. This is not necessarily the case. This is essentially designed primarily as a teleportation craft. The counter rotation principal is in place, and, this is what happens, though it can happen at the speed of thought in this method of travel. This is why the frequency of the principals designed in this craft can't be slowed down in the translation or interpretation for a 3D brain in order to contemplate through a three dimensional thought process. You need to realize you are not a third dimensional construct. You are designed to work on fifth dimensional concepts. To the unknowing eye, this craft when complete, will not be understood. The pilot is the completion of the circuit. Pure LOVE energy is the catalyst for the initiation and activation of the craft. Anyone displaying the polar opposite emotion, or Fear, will not be able to use this. Why is the term 'pure LOVE energy' being used to describe the first process in the craft? Simple. It is referring to the elevated frequency of the human body when activating your 'biological circuit'. Wireless transmission of power is truly wireless reception of energy. We need not transmit a thing when we realize the energy is all around, we simply need to build the receiving vessel or device. The clockwise rotation is aerial, the counter - clockwise rotation is ground.

Teleportation - 'Spending time in time'

One must understand the concept of 'spending time in time'. This is the process where by you experience the totality of the experience. If you understand your entire so - called 'reality' is being perceived or received by you at twenty four (24) frames per second or twenty four (24) cycles per second, we now have a base to work with. What would happen if you exceeded this number of cycle per second? A flickering light pulsed at more than twenty four (24) pulsations per second would begin to take on the appearance of a single non - pulsating light. Therefore, if you could train your mind to go beyond the twenty four (24) cycle per second interpretation of the perception of reality, you would naturally see more reality. For example, contemplate what would happen if a person could train there mind to see forty eight (48) frames or cycles per second. If we take this person and stand them next to someone who can only perceive twenty four (24) frames per second, and ask both people questions about an event they just witnessed, the first person who can perceive more frames or cycles per second actually saw twice as much information as the second person over the same given amount of time. Here we have an example of 'spending time in time'. This is important for understanding what your body and mind will go through during teleportation.

This is the general principle, there are some variances, though this gives a point 'A' to point 'B' description of how things work. The following is happening at the speed of thought.

- 1) The pilot decides the destination
- 2) Focused intension toward the crystal
- 3) A process of harmonization occurs
- 4) The intension of destination decides the frequency
- 5) the counter rotating vortex begins
- 6) harmonization with the  $10^{12}$  hertz frequency occurs (gravity wave - one trillion cycles per second)
- 7) matter is transmuted to light
- 8) This light is pulsating at one trillion cycles per second, pure gravity wave. Perceiving reality at this many cycles or frames per second is hard to comprehend
- 9) Upon the matter being transmuted to the gravity wave, the destination is reached instantaneously where by the vortex slows / stops and light is transmuted to matter once again to complete the cycle.





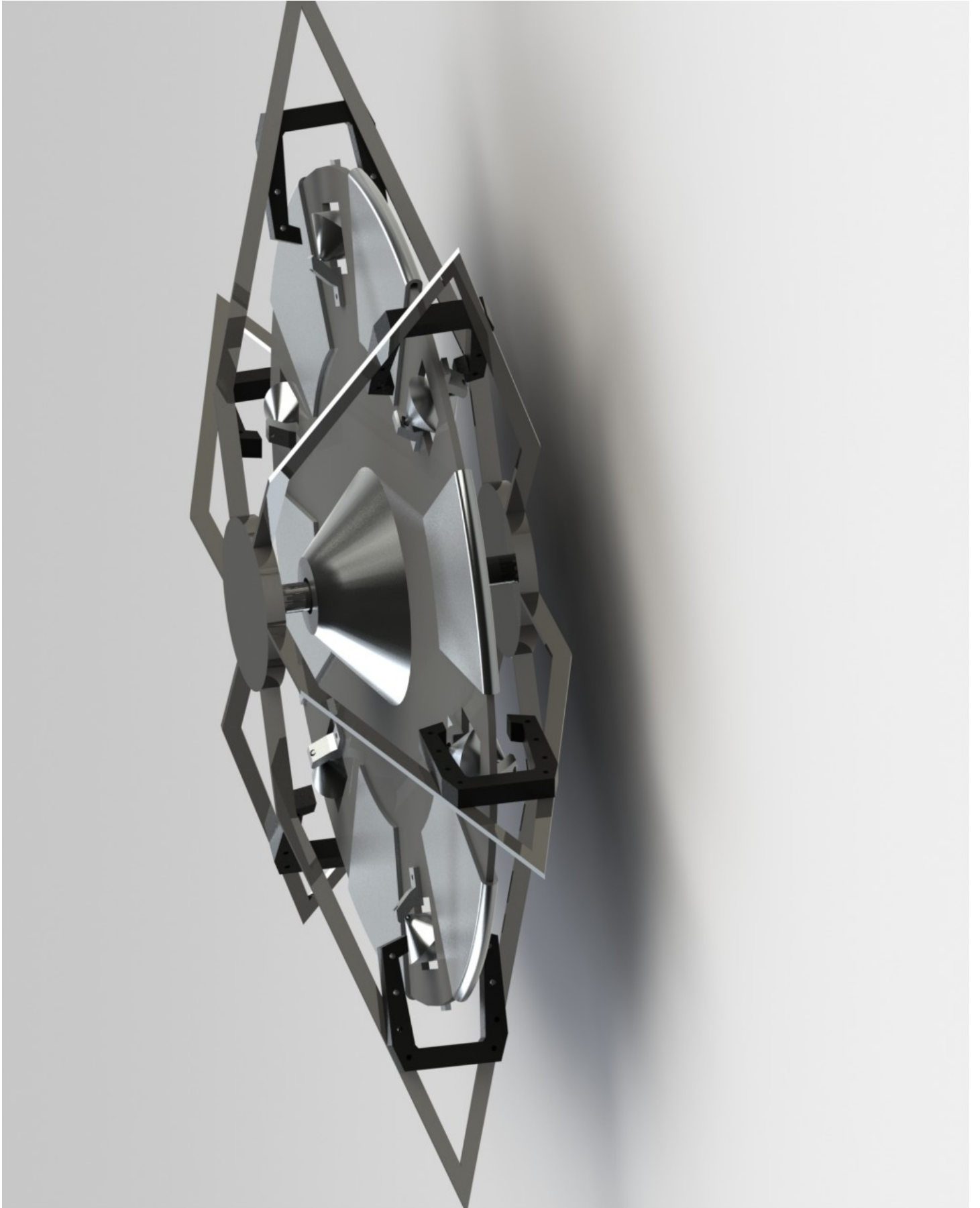

# The Pod Work

Part 1

# ***Cover Page***

***Internal 'Clockwise' Rotating Central Assembly***

***'X2' Prototype Part Construction***

***Workshop Schematics***

***10 (ten) pages*** including cover page

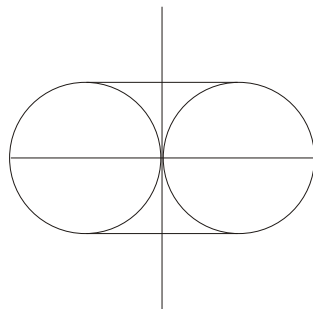

# Contents

1. Cover Page
2. Contents
3. Capacitor Plate page 1
4. Capacitor Plate page 2
5. Outer Utron
6. 'C' Magnet
7. Trunnion page 1
8. Trunnion page 2
9. Central Accumulator page 1
10. Central Accumulator page 2

**Red lines & text:** represent measurement, angular lines of interaction, angular degrees, thickness lines, design lines and technical information / specification.

**Black lines:** represent actual shape and final component design to be machined.

**All drawings are actual size, background page size is A4 or 21 cm x 29.7 cm.**

# X2 - Capacitor Plate x 6 - pg - 1

(Machine Shop Design Schematic)

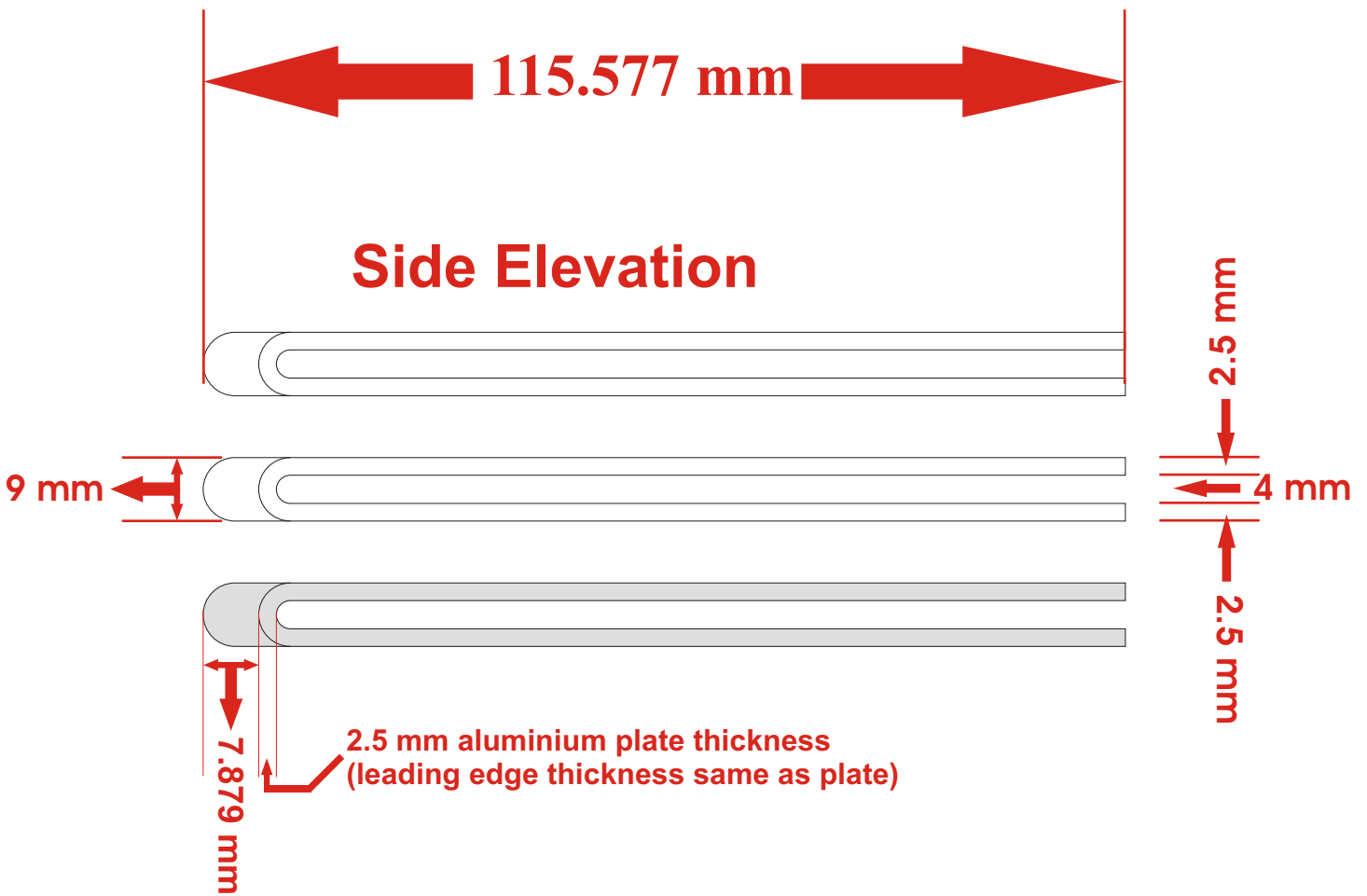

# X2 - Capacitor Plate x 6 - pg - 2

(Machine Shop Design Schematic)

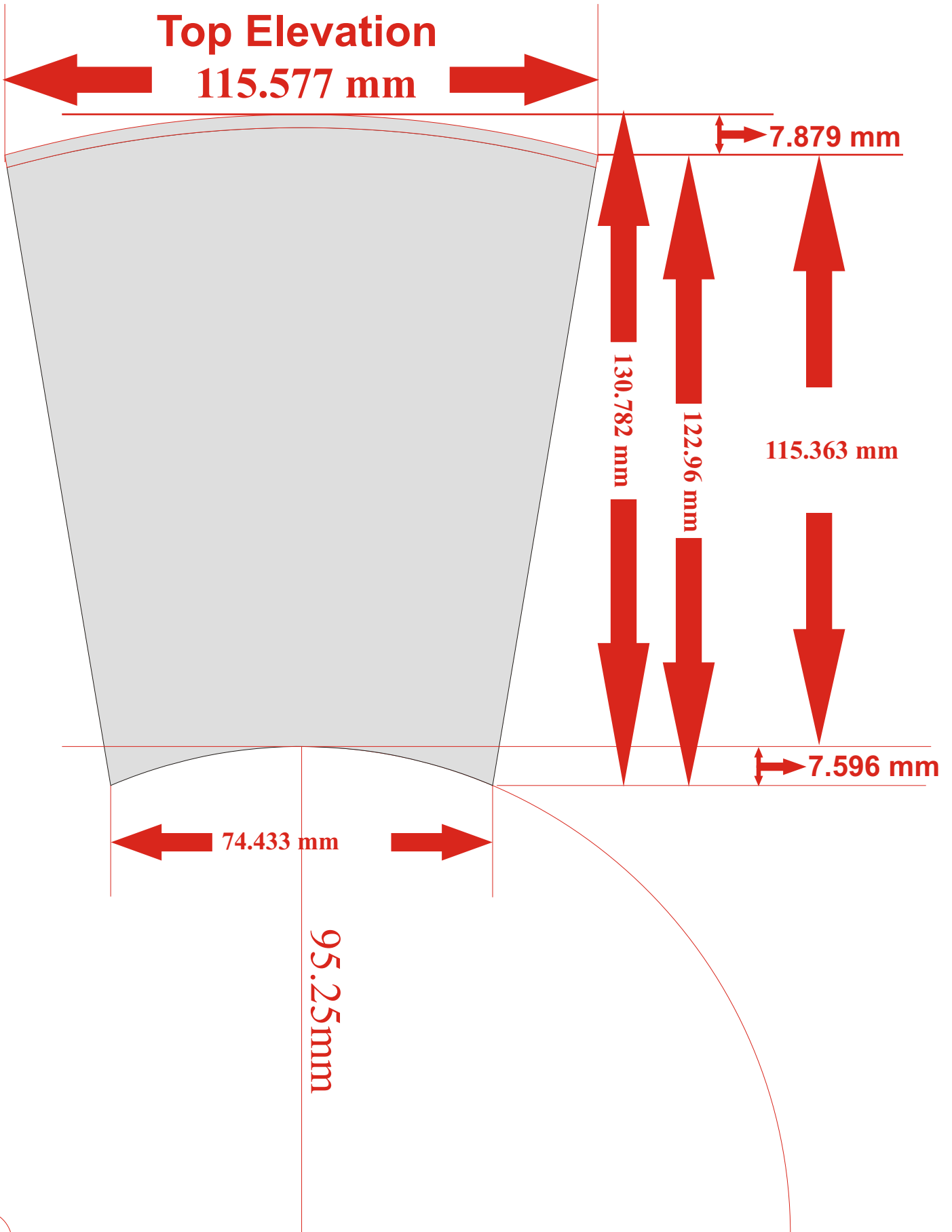

# X2 - Outer Utron x 6

(Machine Shop Design Schematic)

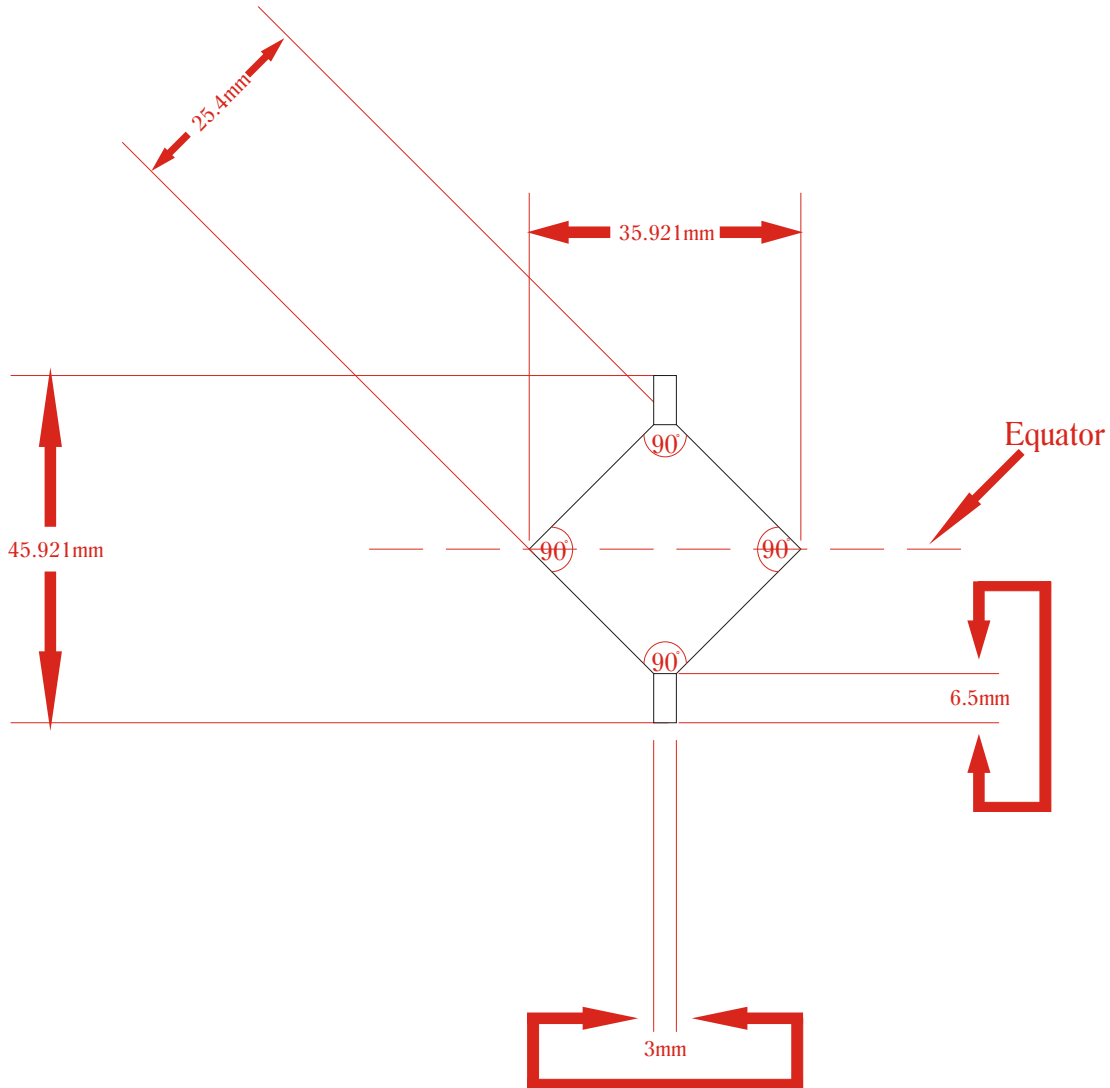

***All one piece, double cones including spindle.***

# X2 - 'C' Magnet x 12 - pg - 1

(Machine Shop Design Schematic)

## Side Elevation

(full measurement / angles for 'one [1]' plate constructed in one piece.  
All plates are identical and each constructed in 'one [1]' piece. This design is for a one piece magnet, with the coil being wound onto the magnet)

## End Elevation

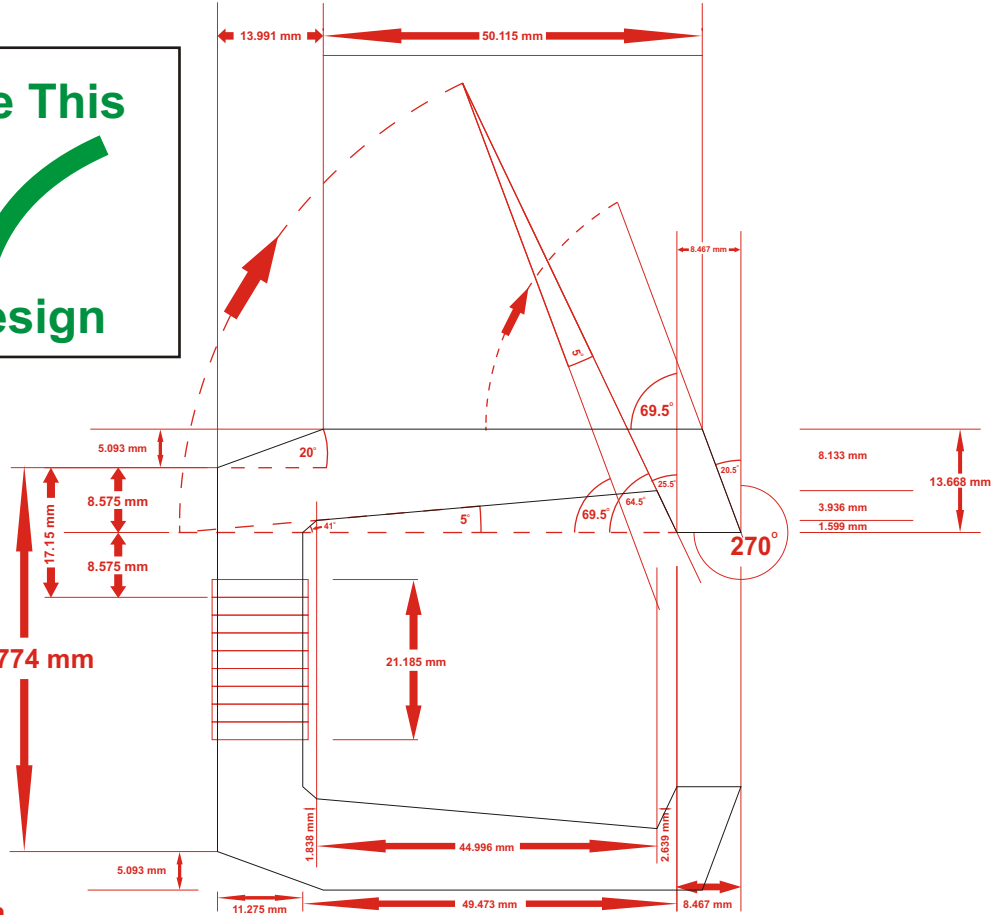
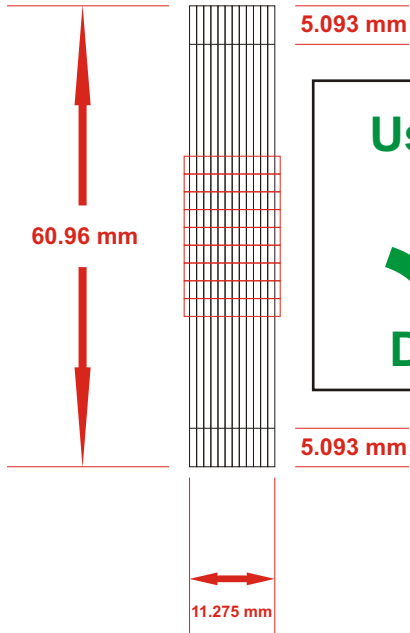

## End Elevation

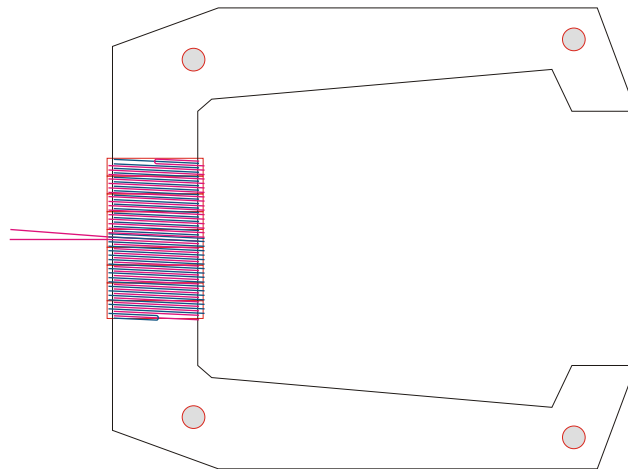
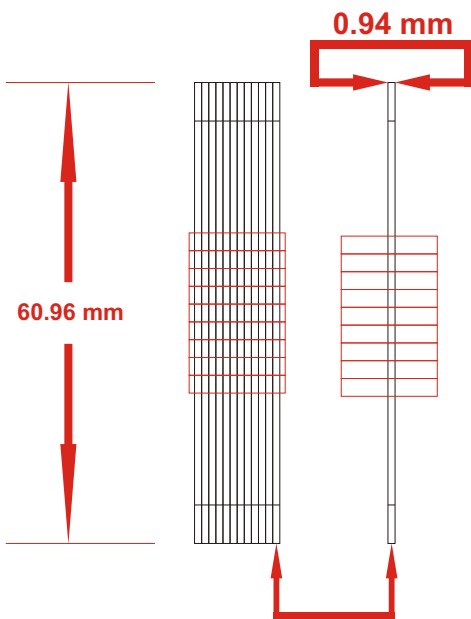

The above diagram represents the 'end elevation' of 'one (1)' plate, which together with the other 'eleven (11)' identical plates form a set, which intern, forms 'one (1)' complete magnet.



# X2 - Trunnion x 12 - pg - 1

(Machine Shop Design Schematic)

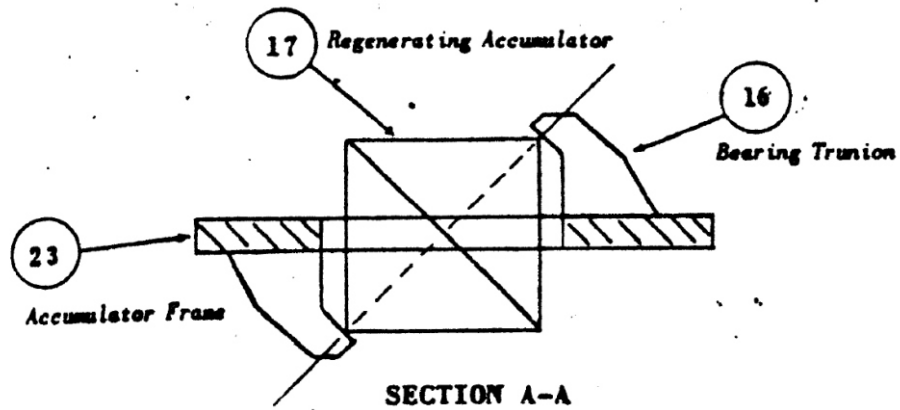

## Side elevation

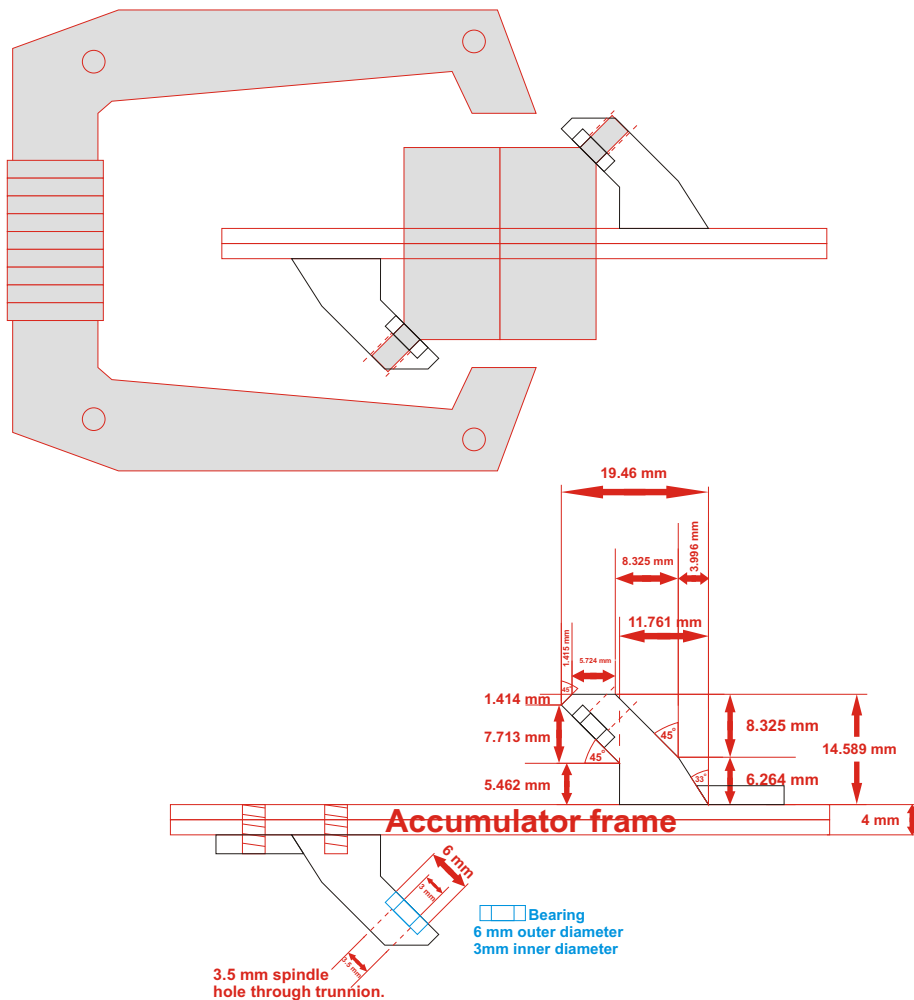

# X2 - Trunnion x 12 - pg - 2

(Machine Shop Design Schematic)

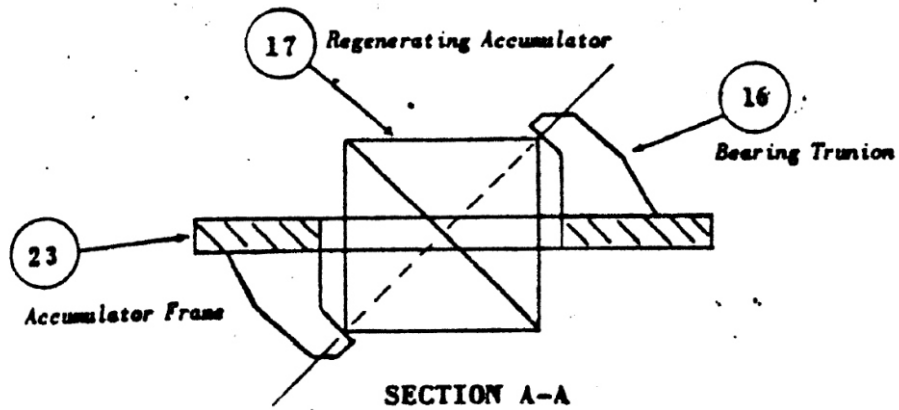

## Side elevation

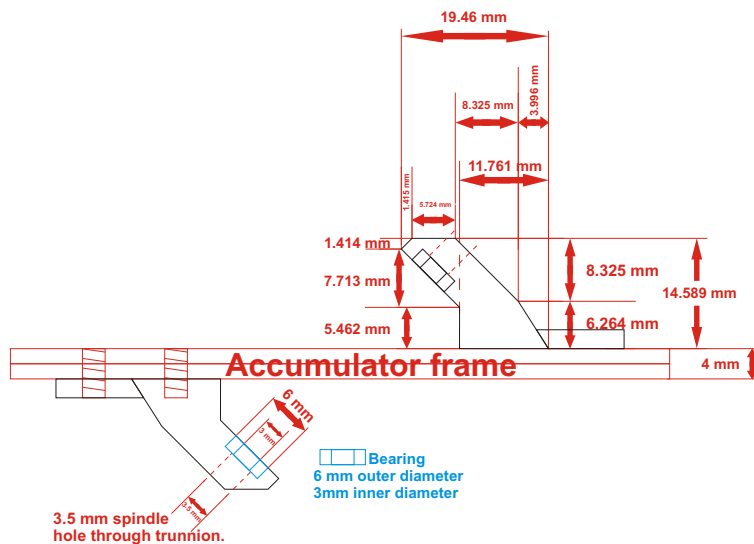

### Trunnion Bearing

## Side elevation

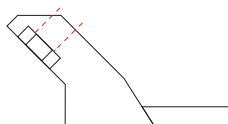

Outer diameter  
W - 6 mm x H - 2 mm  
Center hole  
W - 3 mm x H - 2 mm.

W - 3.5 mm hole on top of bearing through trunnion, in counter - sunk arrangement with bearing, for the Utron spindle to fit in and free spin.

## End elevation

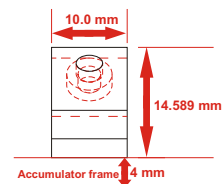

# X2 - Central Accumulator - pg - 1

(Machine Shop Design Schematic)

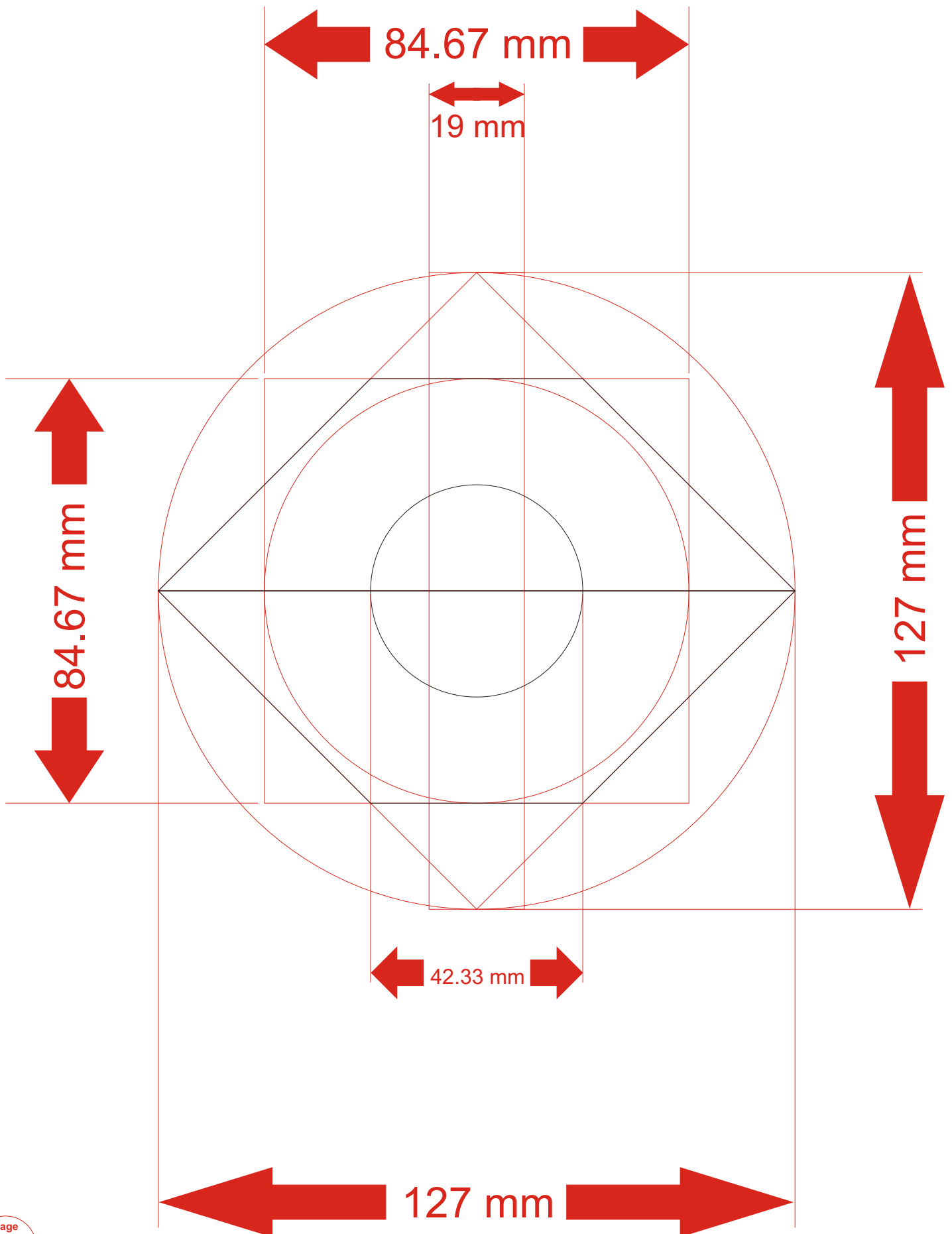

# X2 - Central Accumulator - pg - 2

(Machine Shop Design Schematic)

