

بِسْمِ اللَّهِ الرَّحْمَنِ الرَّحِيمِ
In the name of Allah, most gracious, most merciful

The Resonance Energy Device Explained

Preface

This presentation is a favour from Allah (God), the Thanks is to HIM even though it's the result of more than two years of deep thinking about the resonance energy device invented by Donald Lee Smith. I was interested in this device due to the huge amount of power which it is able to provide. The device has no moving parts and is small in size. This presentation is an attempt to explain two important sources of information about the resonance energy device; they are a document and a video:

The document is located here: <http://www.free-energy-info.com/Smith.pdf>

The video can be seen here: <http://www.youtube.com/watch?v=cQkYAh8Qgb4>

The information contained in the document is free and open to the public. I think that it is time for such information to become widely known - free energy is free because it's for everyone. Energy is everywhere in an unlimited quantity, ready to be taken with minimum effort, the resonance energy device described here is one of the most attractive free energy devices, it depends on a multidimensional transformer which makes possible a harmonic exchange between the positive energy reality and the unseen negative sea of energy. This is possible using a spark-gap arrangement, the energetic symmetry between the positive and negative energy oceans make it preferable to use the term **ambient background energy** rather than the name **zero point energy**. The video pointed to above, is an excellent source that can be viewed in parallel with this work, and when considered together, the reader will understand both the video and this presentation.

At the start of the above video, the inventor explains the importance of the magnetic field in generating electricity. The magnetic energy upsets the background energy and that results in a separation of electrons between the two ends of a coil, this separation of electrons is a source of electric power.

The resonance energy device is based on a very important idea, namely, that magnetism and electricity are two sides of a single entity!

Matter and energy are two aspects of the same thing as Oliver Heaviside expressed in his famous energy equation $E = MC^2$. The electrical equivalent of this in our Resonance Energy Device is:

$$E = (\text{Volts} \times \text{Amperes}) \times (\text{Cycles per Second})^2$$

In this presentation, we will learn together how the device works but before any attempt to use this information, please pay attention to the following caution:



You need to read this document again and again to understand the power behind this device; this device is a power producer! You are near a power production factory but in a small size, this special coil only needs voltage and when we oscillate that voltage, the voltage turns into **real current !!**

This means that even a short-circuit isn't permitted in the collection system if you plan to use HV capacitors. This is not the place for amateurs, please do not attempt to implement or use the information shown here unless you are experienced and skilled. Neither the publisher nor the author makes any representations as for the completeness or the accuracy of the information contained here and disclaims any liability for damages or injuries resulting from your actions.

Let's examine how a magnetic field generates a voltage in an ordinary coil and why our coils lack the energy key that Donald Smith has found!

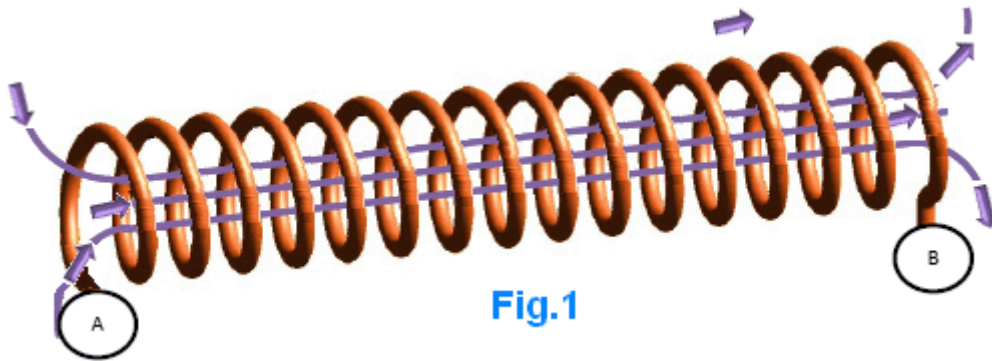

Fig.1

When a magnetic field penetrates a coil, the induced rotating electric field generates additive elementary voltages along the coil. Every turn in the coil receives the same voltage, we extract the power along the length of the coil, but we miss the power available in the area inside the coil !! To understand this, let's examine the induced electric field:

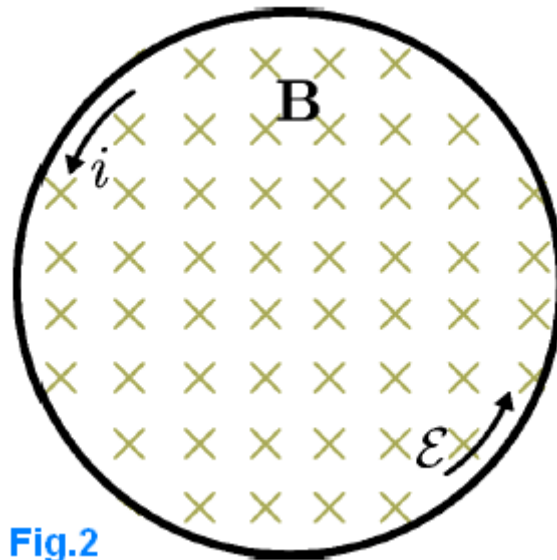
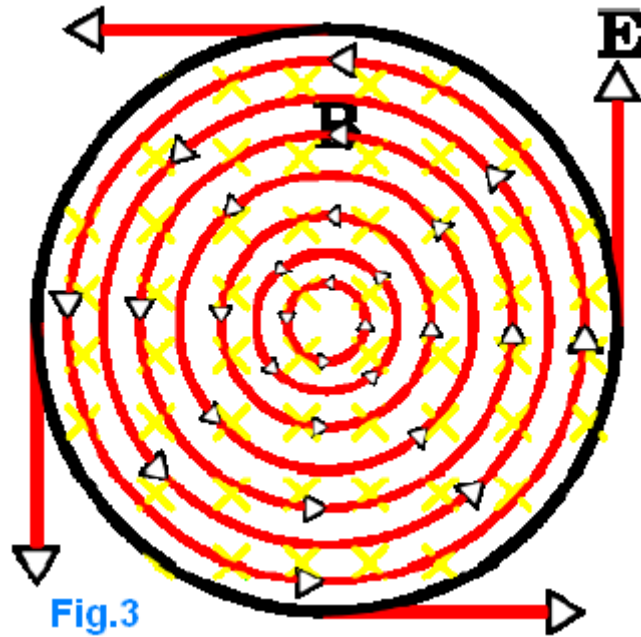

Fig.2

If we examine Fig.2, which represents a single turn of the coil shown in Fig.1, we see that the magnetic field penetrates all of the area inside that ring. This magnetic field will be transformed to a voltage because it will drive a rotating electric field, this field is able to induce a voltage and this induced voltage will cause the current to flow due to the different of voltage between the two points **A** and **B** in Fig.1.

The important, generally forgotten thing about the induced electric field, is its availability inside our coil as shown in Fig.3:



The induced electric field exists independent of the conducting loop. In other words, an induced electric field permeates all of the space within the region of the changing magnetic field, as indicated by the red field lines in Fig 3. What about this field? It is wasted power. It is wasted power at point **A**, as well as all of the distance between the two points **A** and **B**.

If we want to achieve power amplification we have to combine the magnetic field with the induced electric field in such a way as to conserve the non-conservative electric field! The induced rotating electric field will remain non-conservative but we could play with the induced voltage created by that field using a Tesla Bi-filar Coil ("TBC").

We need to extend the capacitive side of a Tesla bi-filar coil in order to benefit from the induced E field to a reasonable degree, if we try to use a flat TBC we will face the same problem in our solenoid coils where we concentrate between two points... The heart of the Resonance Energy device is based on an extended Tesla bi-filar coil (Fig.4)

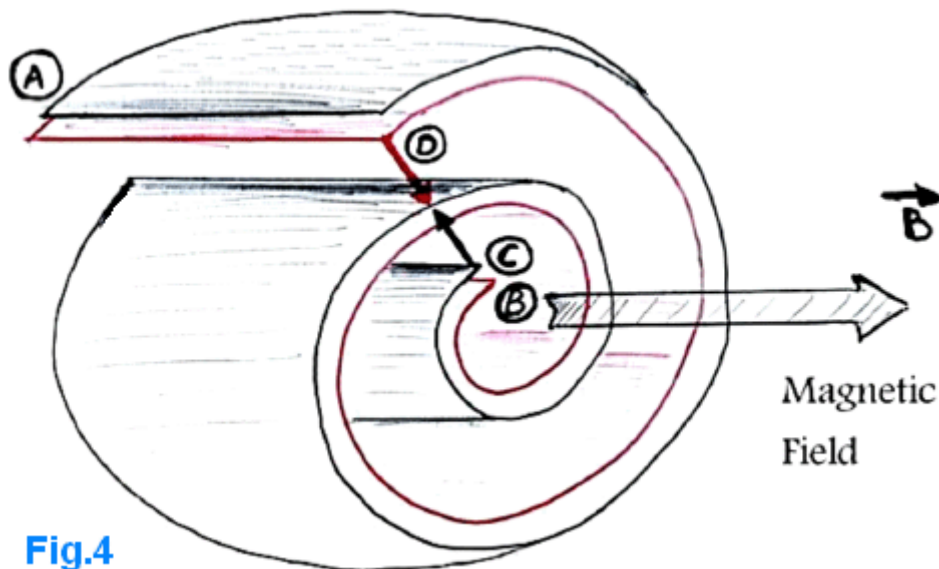

During my search for the specification of Tesla bi-filar coil I wasn't able to find a lot of information such as the resonance frequency of this special coil as if it has been forgotten, although it has been known since 1894!

I felt it's without advantage; fortunately at that time I successfully built a new type of asymmetrical capacitor that has four plates rather than three plates, I was able to replicate my source voltage, I gave it the name C1/C2

system, when I fed C1 with high voltage I was able to take the voltage from C2 without direct contact, the device is based on the electric field interaction between C1 and C2.

The C1/C2 system opened my mind to the possibility of charging a capacitor without the need of direct contact; with the device. I began thinking in a different way, wondering how I could combine the two side of electricity in just one device. The device shown in Fig.4 can be simplified as shown in Fig.5:

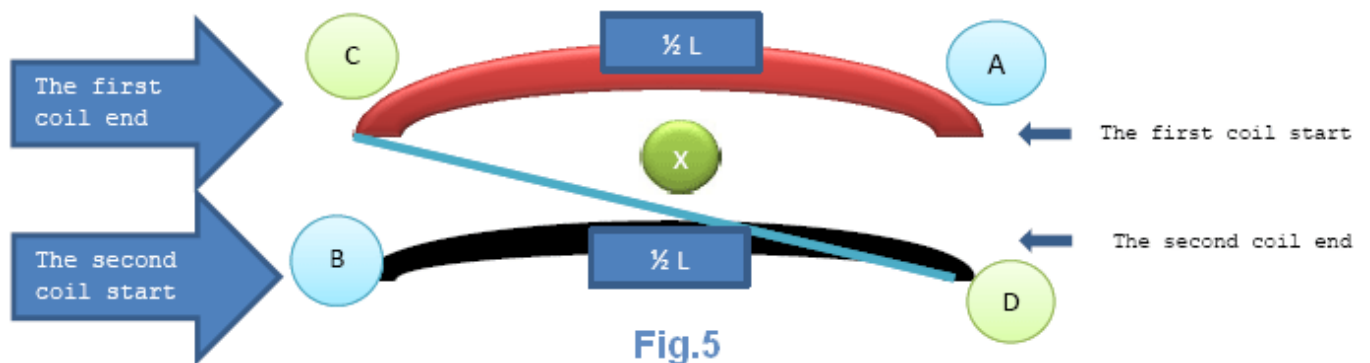

The magnetic side is the path from **A** to **B**, it is the path which the current will follow, and then the magnetic energy will be formed and concentrated inside our coil, the magnetic side is the hidden side of electricity because we can't conserve this state for a long time as we do in the capacitors. This side is directly related to the ambient background energy or zero point energy. (Later we will see why Donald Smith prefers the name of ambient background energy as opposed to ZPE)

To make things easier we could take the permanent magnet as an example, the permanent magnet appears to create the magnetic field all the time without requiring us to provide any visible power for which we have to pay.

The electric side of this amazing coil is the most difficult thing to understand. The capacitor in our extended Tesla bi-filar coil is just one point! It's the point "X" but from a static perspective, we say that it is between points **C** and **D**. The path from **C** to **D** is the way to conserve the direction of current needed to build the coil and ensure the maximum voltage is generated between the two plates of the capacitor. This capacitor is a dynamic capacitor and not a static capacitor. In this capacitor the displacement current is absent... because it gathers the two polarities of electricity in one device. The magnetic side is the current side where the current starts from point **A** and flows to point **B**. The electric side is the point at which the maximum voltage between the two plates exists. I think that this is the most difficult point to understand in the Tesla Bi-filar Coil, because we see it as just a coil and not a coil with a built-in capacitor!

Back to 1894 and take a look at what Mr. Nikola Tesla said about his bi-filar coil:

My present invention has for its object to avoid the employment of condensers which are expensive, cumbersome and difficult to maintain in perfect condition, and to so construct the coils themselves as to accomplish the same ultimate object.

Let us start by analysing how the extended Tesla bi-filar coil works. Imagine that the following drawing is a charged, extended Tesla coil with the positive and negative parts, shown as red and black plates respectively.

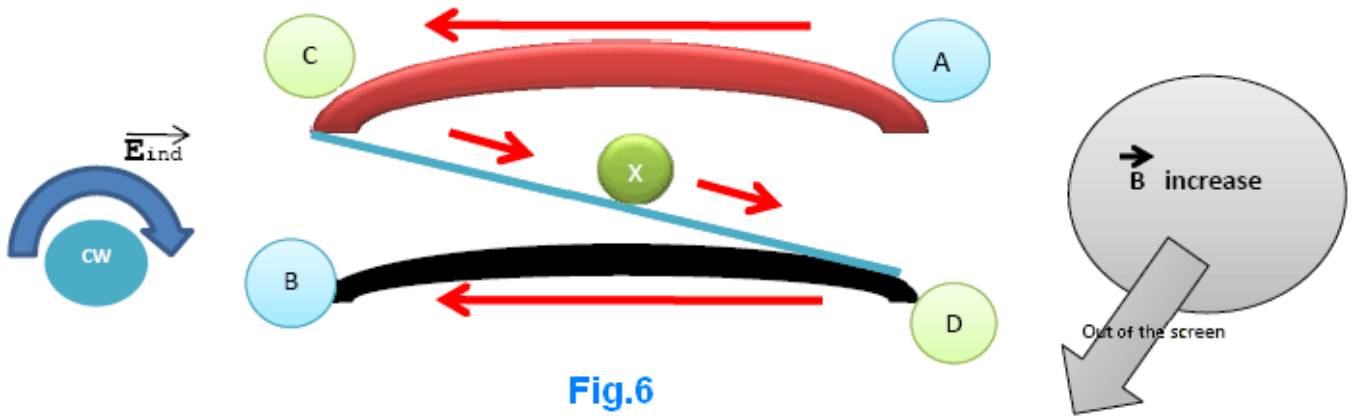

Fig.6

When we connect these two plates by their points **C** and **D**, an electric current will flow from point **A** to point **B** as shown by the red arrows. When the induced electric field finds a coil which is wound counter-clockwise (“CCW”) – the red plate - versus another coil wound clockwise (“CW”) – the black plate - this electric field will generate an induced voltage which will tend to recharge the capacitor again!

The rotating electric field will start to build an induced electric voltage from point **B** which will be 0V in this case because the induced electric fields rotate in a clockwise direction. When the magnetic field increases, the electric current will flow counter-clockwise and so the direction of the magnetic field will be out the screen as indicated in Fig.6.

In this case we achieve a cost-free voltage difference between adjacent plates. This situation attracts electrons which were not previously available, to become incorporated and produce a very large net gain in potential, this gain is real !!

The induced rotating electric field flows in closed loops but this design causes it to build a voltage difference between adjacent plates. This fact prevents the voltage difference between the adjacent plates from dropping and it makes the replication of electric power with radio frequency a practical operation.

Because of this, we can understand why resonance can't produce the power but it replicates the power with radio frequency and this is the secret of the huge power which this device is able to give with the equation which Don Smith gave us:

$$\text{Power in one second} = \frac{1}{2} C V^2 F^2$$

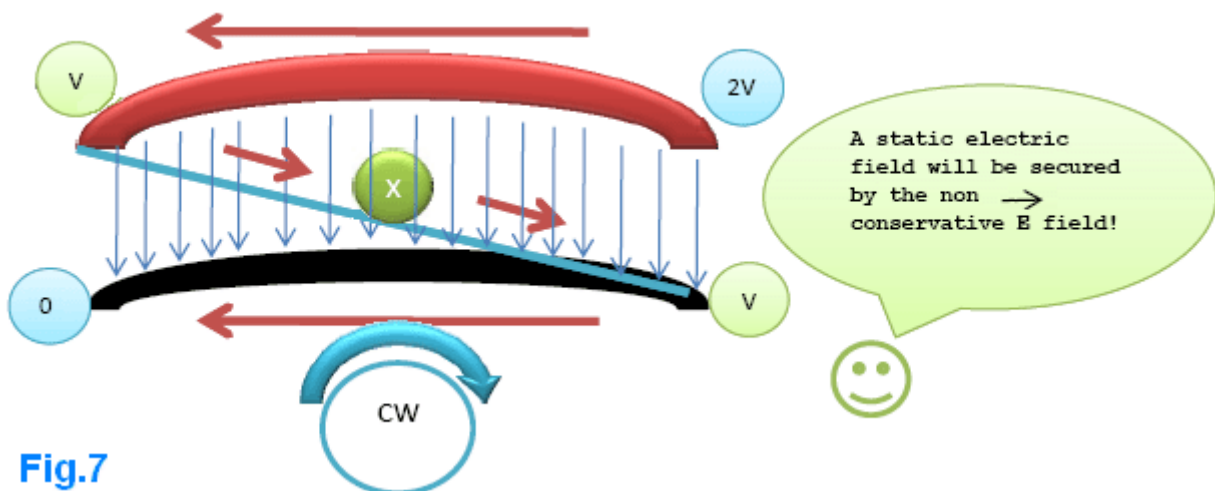

Fig.7

The induced rotating electric field will build induced elementary voltages; **B** is the starting point for that field, so it will have 0V but when we arrive at point **D** it will have V volts, which same voltage will be available at point **C**. The induced rotating electric field will continue it's rotation producing a value of 2V at point **A** !! (Fig.7).

A question arises: where is the capacitor if **C** and **D** both have the same voltage?

The capacitor in our extended Tesla bi-filar coil (TBC) is a dynamic capacitor, it will be formed only when the coil oscillates. When that happens, the induced electric field will give **C** and **D** the same value of voltage but every adjacent turn will receive the same difference of voltage needed for attracting ambient electrons which weren't originally in the system but now are incorporated in large numbers, providing the excess power. This capacitor appears due to the junction **CD**, and from a dynamic point of view, it is the point **X**.

This device treats the magnetism and electricity as if they are the same thing. When this happens both sides help the other side. The displacement current is absent here because it appears when we separate electricity and magnetism. When we do that, we fill the gap by introducing something isn't real. The displacement current does not exist !!

When you move a permanent magnet in the air, **an induced electric field will appear regardless of the presence of a coil**. The electricity is there, it comes from the background energy and returns to its background level, both electricity and magnetism have the same origin, the magnetism is the energy side (magnetic field), the electricity is the physical side (electrons).

The physical side appears when we place a conducting coil in an area where there is a changing magnetic field. The magnetic field causes the electrons to rotate CCW and produce voltage and rotate CW and produce current, voltage electrons appear to be more negative because they are more active, current electrons appear to be less negative. We seek the number of electrons separated by the changing magnetic field. The current (I) is the energy killer because it absorbs the power of the voltage electrons!

In this system, the magnetic field penetrates inside a special capacitor coil where both sides of **electric power** are found in a unified state. We discussed the phase when the capacitor discharges across itself, and now it is time to see how the coil will charge the capacitor with a reversed polarity.

It's important to review the resonance in a normal L/C circuit to understand the work of the extended TBC. Imagine that you have a charged capacitor, when connected to a coil a current starts to flow, when the current reaches its maximum value, this means that the capacitor was totally discharged, the magnetic field will have the greater value and start to decrease and induce a voltage which will charge the capacitor again with the opposite polarity.

The same will happen in our extended TBC, when the magnetic field reaches its maximum value it will then decrease and induce a voltage which will charge the capacitor again, the complexity here is to understand the positions of coil and capacitor.

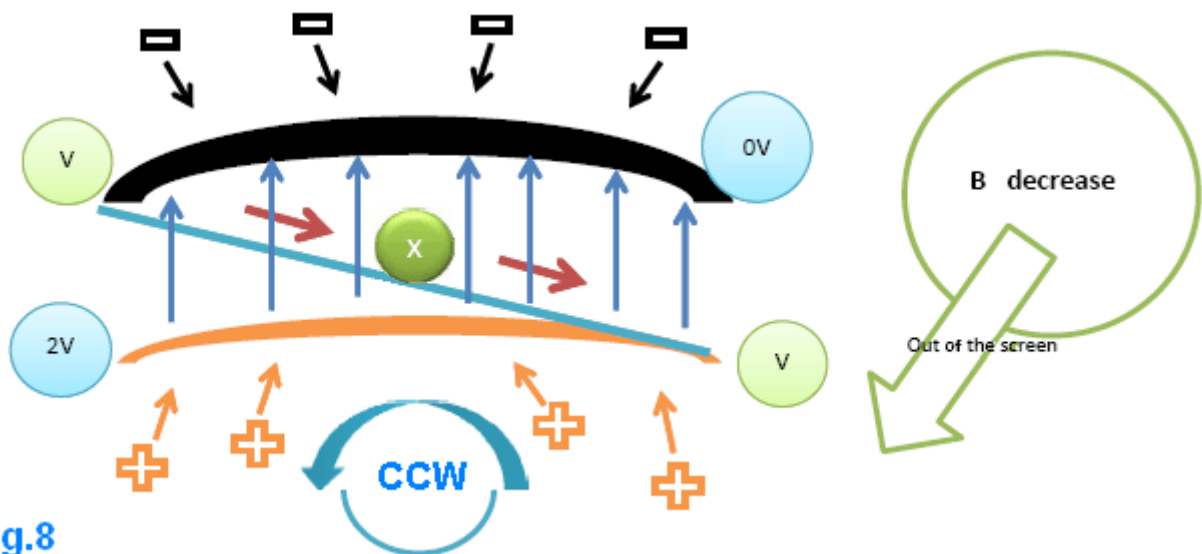
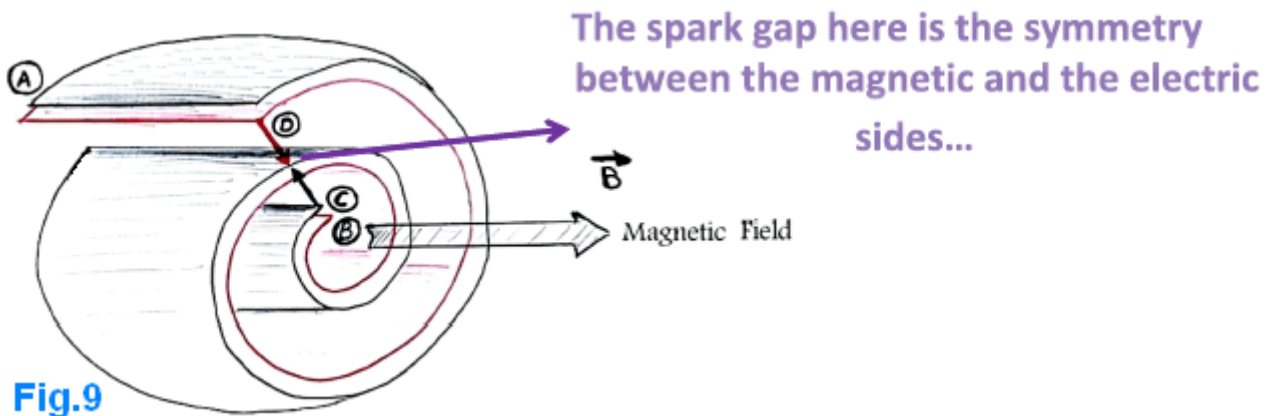

Fig.8

In a dynamic perspective the coil sees the capacitor in the **X** position, the coil situated between **A** and **B**, comparing this to what happens in a normal L/C circuit at this phase the coil has to drive a current **outside its region**, the outside region between **A** and **B** has to be position **X**. when the magnetic field induces a current to recharge the capacitor between **C** and **D**, the induced electric field will do this job because it will change the

direction of rotation to be CCW (Fig.8), and this behaviour will tend to keep the current at a high value while the voltage increases! The position of the capacitor in this device has to be the position of a spark gap. A spark gap in this position will improve the performance **dramatically** and amplify the power gain.

The Resonance Energy device works with radio speeds above 20 kHz. The ambient background electrons are usually found in a dormant or inactive state and this makes the drawing-in of ambient electrons a difficult operation. For this reason, we need an earth connection to improve the performance of this system, later in the video, Don Smith talks about something new, the earth connection isn't needed because there is something called [air grounding](#).



To activate air electrons effectively we need another source of power, actually this source of power exists as a negative energy but before we go further, we have to see the symmetry between the electric and magnetic sides. When we start from **A** to **C** we have **half coil-capacitor** while from **D** to **B** we have **capacitor-half coil**.

To understand how our extended TBC receives negative energy, it is better to see the way in which the device oscillates. There are two methods of feeding this coil:

The direct method

Here we have to know the resonant frequency of this coil or alternatively, we need to have the resonant frequency covered by our feeding circuit. This method is the best because we don't need lots of power, because when we achieve resonance our extended TBC will have a very high impedance, and so, a maximum voltage will be available between **A** and **B**, and fewer turns will be needed in the **reactant coil L2**.

The indirect method

Here we don't have to know the resonant frequency, if we feed this coil from **A** and **B** the capacitor will charge. The spark gap has a very high resistance and it will not fire until there is a voltage difference between points **C** and **D**, at that moment a spark will occur, and when that happens, the resistance of the spark gap drops from a very high value to very low value and that short-circuits any power coming from the power source until the natural coil resonance finishes!

When the capacitor is fully charged, the maximum voltage appears between points **A** and **B** which is the coil side, **when the spark occurs the capacitor will transform into a coil which has a capacitor built into it!** This operation provides the natural resonance needed without causing any problems.

Caution!

When we feed this coil from point **A** to point **B** and then disconnect it from the power source, you would then expect to discharge it by short-circuiting point **C** to point **D** (usually from the location of spark gap). If you do this and then touch the coil **you will definitely receive a substantial high voltage shock!** Even if you see the spark, the spark will not discharge this capacitor immediately but it will cause the coil to oscillate again and recharge itself. This device isn't a simple capacitor because when you short-circuit the spark gap it will transform the electrical energy into electromagnetic energy capable of recharging the capacitor again.

If you try to short-circuit points **A** and **B** in an attempt to discharge the extended TBC, then these two points will **transform** into electric points (due to the symmetry). From a static perspective, the capacitor can take an **AB** position as well!

The solution is to short circuit **C** to **D** permanently and then short circuit **A** to **B** at the same time.

As I mentioned before, there is a need for extra energy in order to activate air electrons effectively. In reality, this is not exactly what will happen as the arrangement is complicated. The negative energy enters this device in an unusual way. The extended Tesla Bi-filar Coil will supply reactive energy in enormous amounts because there are common characteristics between reactive energy and negative energy. Reactive power is a kind of electrical power, measured in volts-amps-reactive (“vars”) which cannot do work in its present form. For sinusoidal waveforms, the formula for reactive power is

$$\text{Reactive power} = V \times I \times \sin(\theta)$$

The reactor coil in our system is a shortened version of a normal parallel L/C circuit. The output energy received in the reactant coil has to be a reactive energy because of the presence a coil in parallel with a capacitor. The phase angle between current and voltage is 90 degrees, and so, the active energy in this case will be zero.

$$\text{Active power} = V \times I \times \cos(90 \text{ degrees}) = 0$$

The system acts like a negative resistor, it's a **non-dissipative** system because it's an energy absorbing system:

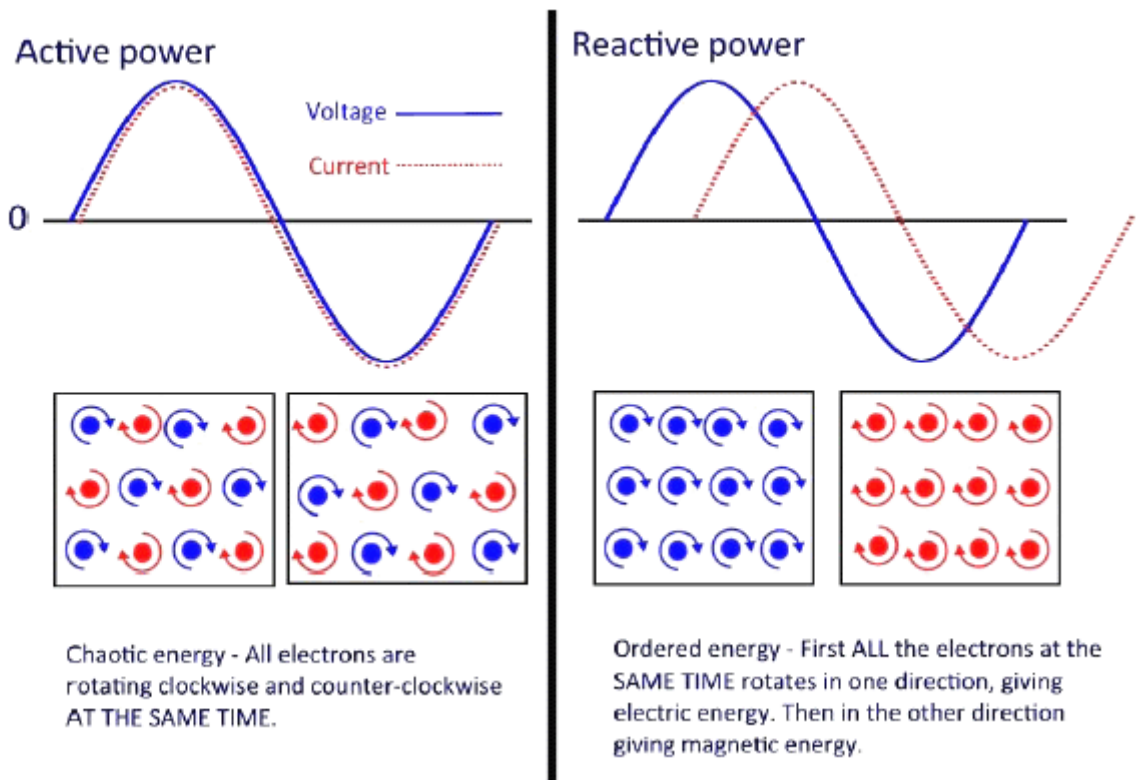

Fig.10

The reactive energy in this system is an advantage. The energy is ordered and so we can easily achieve **super-conductivity** at room temperature!

As shown in Fig.10, active energy is a **chaotic energy** and so it is not easy to get rid of resistance. The important point where we need to focus our attention is where the voltage has a maximum value the current will be totally absent. Negative energy is a kind of electric **power** obtained when sparking (on-off) from a high voltage direct current (Fig.11).

Fig.11



This is why we need a high-voltage diode in our power supply circuit. The resonance in a normal parallel L/C circuit does not require this.

If we connect a spark-gap between point **C** and point **D**, then the negative energy will be drawn into our system with the same speed as positive energy! The symmetry between the magnetic and electric sides in our positive energy reality will open the correct door for the undetectable negative energy reality!

Initially, when the capacitor starts to discharge, the current increases but the induced rotating electric field will tend to keep the voltage at a high value. The capacitor discharge through the spark-gap (which requires a large amount of voltage), the current flow does not start immediately. Initially, the current increases but the spark does not occur. This pushes the voltage up higher (behaviour which is known in parallel L/C circuits), then the current increases to a high value very quickly, while the voltage is drawn down to a level which cannot sustain the spark. When the capacitor is totally discharged the current flow through the spark-gap is at its maximum value. Consequently, the extended Tesla Bi-filar Coil produces a square wave rather than the expected sine-wave which is produced by an ordinary parallel LC circuit. The square wave produced when the spark occurs, contains waves of all frequencies and so, even if the time during the spark is short, there will still be thousands of oscillations in that time. I know that it is not easy to visualise this, but it is what actually happens.

This special genius design solves the most difficult problems in cold electricity, due to its reversed behaviour compared to hot electricity. Cold electricity prefers to flow along materials which we consider to be insulators while hot electricity prefers to flow along materials which we consider to be conductors.

According Tom Bearden, with negative electricity the capacitor performs in the way that a coil does with hot electricity, and the coil will perform like a hot electricity capacitor (Fig.12).

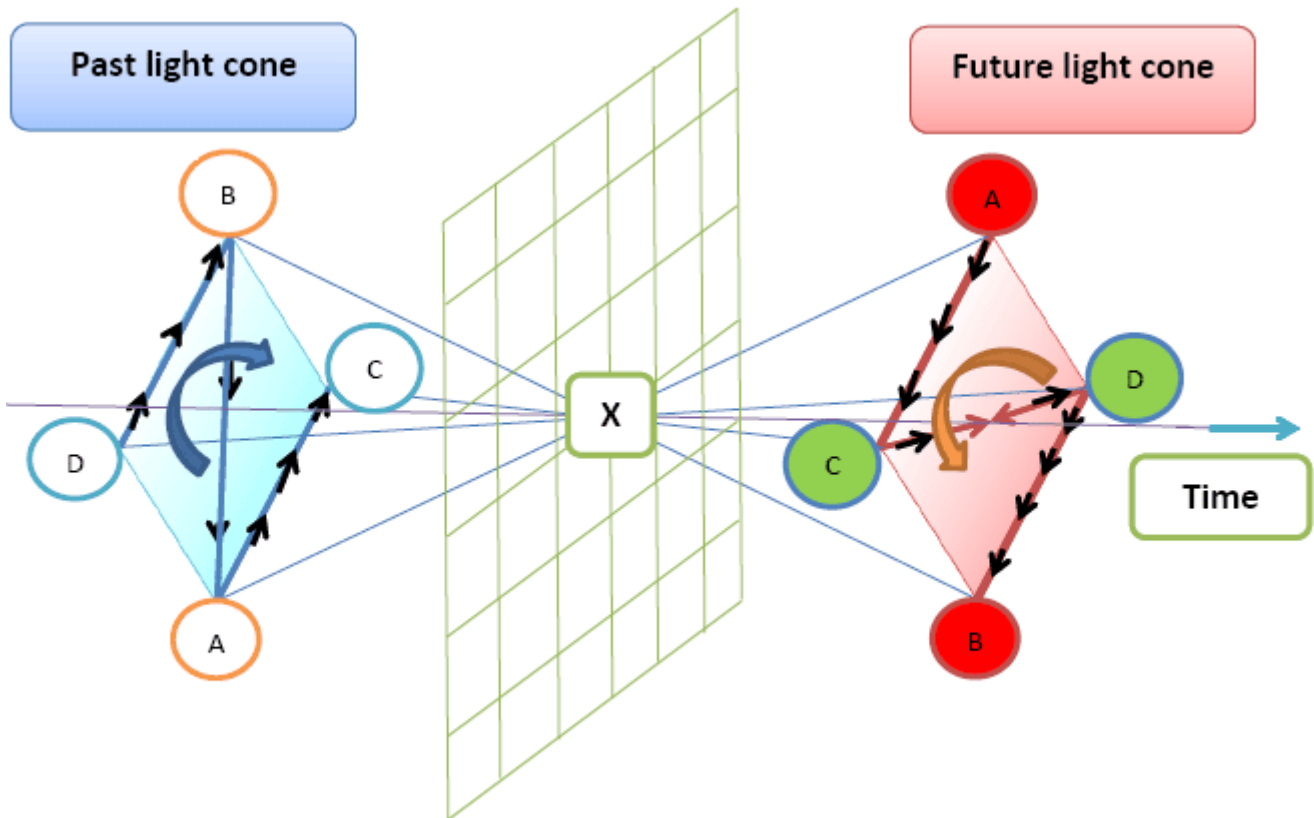

Fig.12 (the capacitor is discharging across itself)

the above illustration is an attempt to understand how cold electricity work but it's better to take a look at Floyd sweet explanation of his VTA device in the Appendix (page A-1209) :

it is important to note that so long as positive energy is present in a **positively-flowing time regime**, then unity and over-unity power gains are not possible. The summation of the losses due to resistance, impedance, friction, magnetic hysteresis, eddy currents and windage losses of rotating machinery will always reduce overall efficiency below unity for a closed system. The laws of conservation of energy always apply to all systems. However, **the induced motional E-field changes the system upon which those laws need to be applied.** Since the vacuum triode operates in **more than four dimensions** and **provides a link between the multi-dimensional reality of the quantum state and the Dirac Sea**, we are now dealing with an open-ended system and not the "closed system" within which all conservation and thermodynamic laws were developed. To achieve unity, the summation of all magnetic and ohmic losses must equal zero. To achieve this state, **negative energy and negative time need to be created.** When this is achieved, **all ohmic resistance becomes zero and all energy then flows along the outside of conductors in the form of a special space field.**

The above explanation describes the VTA device but also demonstrates the work of the Resonance Energy device of Don Smith !!

The correct model of capacitor is the extended Tesla Bi-filar Coil because it provides a link between the multi-dimensional reality of the quantum state and the Dirac Sea of negative energy. From a positive energy perspective, **AB** describes the coil while **CD** describes the capacitor, **but** the coil will transform into capacitor **AB** in the region of negative energy; and in the same area the capacitor will transform into the coil !!

How can we explain this physically!?

The energy equation and Dirac's equation call for both positive and negative energy. Thus they are symmetrical with respect to energy, as are the forces of physics positive **repulsive** forces increase positive energy, while negative **attractive** forces increase negative energy. According to the modern kinetic theory of mass-energy, negative energy would merely be a **vibration of charges at right angles to our ordinary dimensions in an "imaginary" direction.** (Fig.13).

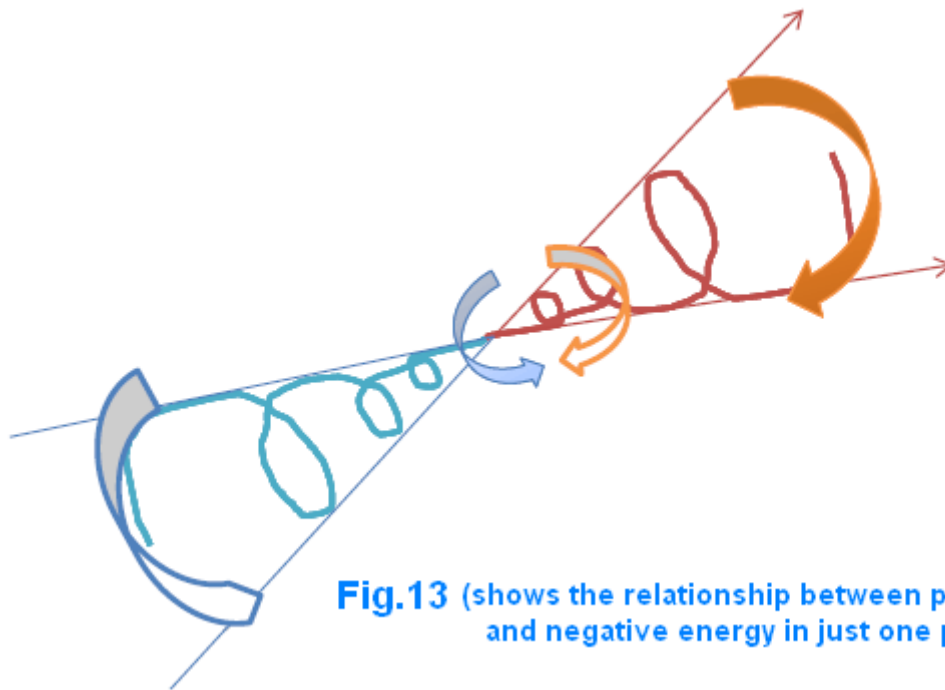

Fig.13 (shows the relationship between positive and negative energy in just one phase)

To understand Fig.13 correctly, we need to remember that we are confined by our positive energy reality; in our extended Tesla Bi-filar Coil we need the negative energy in our positive side, the spark gap in CD position is the flexible place for both positive and negative energy to be combined.

Tom Bearden has an important book entitled "Energy from the Vacuum". The following text is on page 236 where he explains the specification of a true negative resistor:

The true negative resistor is an open dissipative system *a priori*, and equilibrium thermodynamics therefore does not apply. Instead, the thermodynamics of open systems far from equilibrium applies. The negative resistor freely receives energy from outside the system (from the environment), and "dissipates" it in interception and collection actions inside the system, to freely increase the available potential energy in the system. In circuits, the main characteristic of a negative resistor is that the environment freely furnishes some excess energy to (i) power the load, and/or (ii) move the current back against the voltage, particularly when shunted across the back emf region of the source dipole. The *operator* does not have to furnish this excess energy dissipated to propel the current backwards or dissipated to power the load!

The true negative resistor in our system is the **blue extended TBC** where negative energy moves the current back against the voltage; **this power** will charge the coil electrically if it's acting as a capacitor!

The electric current in the negative energy region (**past light cone**) works in a reverse manner compared to the electric current in positive energy region (**future light cone**), the symmetry between the magnetic **energetic** side and the **physical** electrical side will curve space for the negative energy power to enter our device through our **flexible** spark-gap zone which represent a one dimensional capacitor **X**, the negative energy which can be represented by attraction forces will find its way through the spark-gap to increase the electric energy through **AB**, the system will continue its divergence and the clockwise rotation of the negative energy current will increase the counter clockwise rotation of the hot electric current (potential energy), this tends to amplify the power between point **A** and point **B** which represents the voltage gained by this virtual current!

We are examining the first instant when the capacitor discharges across itself (transform into coil), the curved **AB** space will transform into one point in the negative energy sea which is the capacitor in our **imaginary extended TBC**.

Similarly, when the magnetic field collapses and charges the capacitor across **CD**, the magnetic field returns to its background level, **the space-time continuum is reversed by the fields which are produced in the presence of excited coherent space flux**. These quanta have been attracted from, and ultimately extracted from, the virtual vacuum, the infinitely inexhaustible **Diac Sea** (from Floyd Sweet papers in the Appendix)

Like charges have repulsion behaviour on the positive energy side, while they attract each other in the negative energy region. This information is essential for an understanding of the nature of the negative energy sea.

When the turn comes (second time period) for our capacitor to be charged again with opposite polarity, the system will diverge toward negative energy space to close the loop in that space !! The current passes from **C** to **D** to charge the capacitor but in the virtual dimension it starts from **D** and finishes in **C**. This power will charge the capacitor magnetically if it's a coil.

As you see there is positive real energy and undetectable negative real energy. I think that Don Smith preferred the name *ambient background energy* as opposed to *Zero Point Energy* because there are two regions from which we can take power, namely, **over ambient background energy** and **below ambient background energy**.

At this point, we can understand why cold electricity prefers insulators rather than conductors. This kind of power is capable of running in an imaginary dimension **parallel and reversed** relative to our ordinary, familiar dimension. But... according to Floyd Sweet; **when run in parallel with positive energy however, cancellation (annihilation) of opposing power types occurs**. This has been fully tested in the laboratory.

This applies to the chaotic positive energy flowing regime time when voltage electrons (ccw rotation) and current electrons (cw rotation) run together at the same time, our Reactive Energy resonance system works in harmony with negative energy, our previous study allows us to draw us some important conclusions:

For the first time period, we have (C discharging across L);

+ energy increase magnetic energy ---- I

- energy increase electric energy ---- V

For the second time period we have (L charging C);

+ energy increase electric energy ---- V

- energy increase magnetic energy ---- I

since magnetic energy is the current and electrical energy is the voltage and because they are out of phase (reactive energy), positive energy will work in harmony with negative energy and no cancellation will appear.

Our extended TBC is a very important device not only because it can supply unlimited electric power but it give us an exceptional opportunity to understand the way that energy flows inside our universe!

When the device oscillates it produces cold electricity and hot electricity, this means that the device is able to relate to both positive and negative energy. The flow of energy has two directions; from positive to negative and vice versa. Let's think about the physical way in which things work.

In this analysis I'm trying to explain some deep physical aspects about positive and negative energy. As

illustrated in Fig.12 and Fig'13, it is important to consider energy flow in relation to time. These two pictures just represent my thoughts and understanding of the subject.

Cold electricity has the ability to produce an electric response when it interacts with metal surfaces. This can also be seen in the Casimir Effect where two non-magnetic metal plates, which are not carrying an electrostatic charge, are suspended very close to each other. The plates do not hang straight down but move towards each other.

Cold electricity has the ability to produce an electric response when contacting metal surfaces because it's able to ionise empty space. In our extended TBC, when the spark occurs, we are actually colliding the space-time field through one point (the spark-gap).

The space-time field is, in my opinion, the space where negative and positive energy exist together, they exist together but cancel each other out due to a constant ratio. If we take a mass with a gravity field around it, and we move the mass and create a mass current, a new field is also created. It is a different kind of gravity field with no source and no sink, when the speed of the mass increases, then the created gravity field increases also. If the mass reaches the speed of light, then this means that it has the value $E = mC^2$ as a positive energy. mC^2 is the maximum value exchange between positive and negative energy admissible by zero point fluctuation (ZPF) for that mass to exist the way it does in its time-space field, the mass has two options to reach the speed of light:

1. It will transform into exotic matter.
2. It will break the time-space structure.

The only places which provide these two conditions are black holes. Black holes exist in the centre of galaxies which provide the rotational energetic symmetry between the mass and gravity field - see Fig.14, Fig.15 and Fig.16.

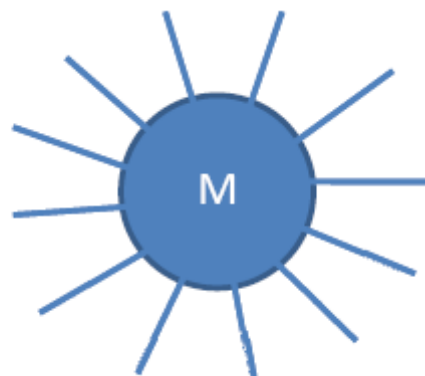

Fig.14 GRAVITATIONAL FIELD

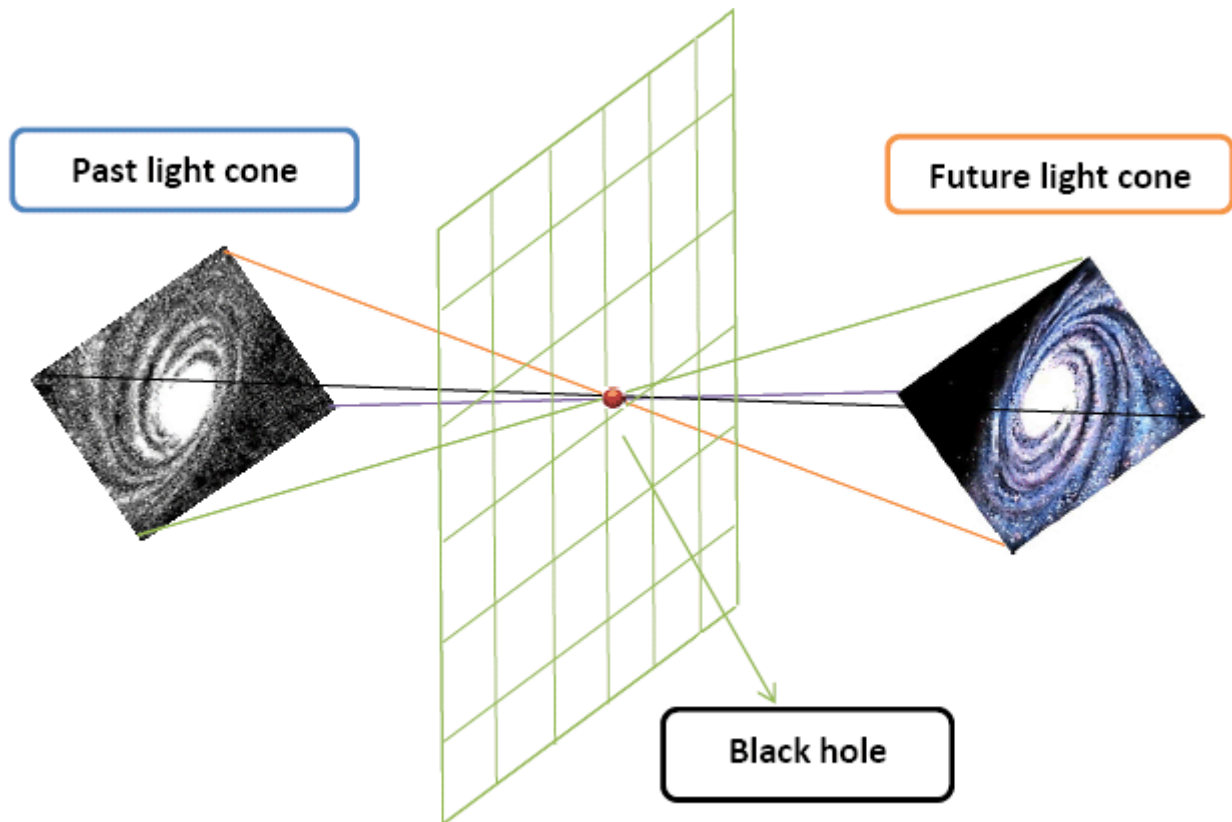

Fig.15 notice the similarity between the black hole and the spark gap



Fig.16 The massive spiral galaxy NGC 1365 has a huge black hole in it's heart, spinning at nearly the speed of light

For a spiral galaxy to maintain its shape with cosmic dimensions (the diameter of galaxy may exceed 100,000 light years) there is a need for a negative energy to be the underlying energy for space-time throughout all of that galaxy. That negative energy has to transport virtual particle instantly! The transformed physical matter (including space-time!) provided by black holes furnishes an excess of positive energy in the galaxy, providing stability and symmetry. Black holes are not a fracture in space-time but they are essential.

The above explanation will help to clear the way for a better understanding of the nature of electric energy. This explains why a sharp positive-going DC electric pulse interacts with negative energy to produce cold electricity which is an instant response from the negative energy sea. This response does not start from the spark-gap, but it ends in it!

The negative energy will rotate to finish in the spark gap, this will squeeze the space-time to provide excited coherent virtual particles which in turn produce electronic responses when contacting a metal surface. From my point of view, the electronic responses created in metal surfaces have a magnetic angular momentum. Cold electricity is able to charge a capacitor to a much higher voltage than the capacitor's voltage rating, even if the capacitor's rated voltage is low. The question which springs to mind is; do electric fields inside a capacitor charged with cold electricity really exist?

If the answer is yes, then why isn't the capacitor destroyed? In my opinion, it is because the electronic responses caused by cold electricity have magnetic angular momentum instead of electric field lines. I suggest that the presence of magnetic field lines between the positive and negative plates of a capacitor charged with cold electricity are actually as shown in Fig.17.

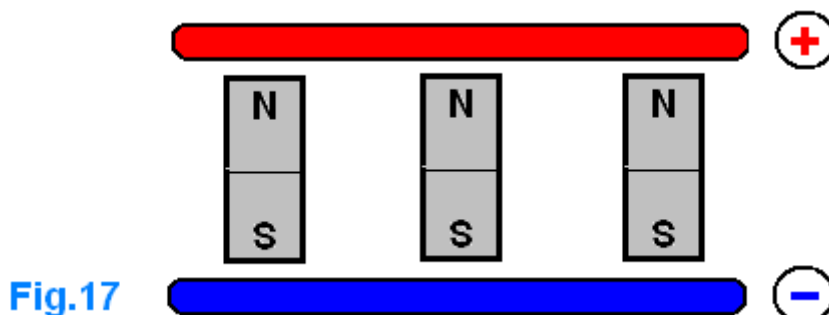

Fig.17

When the spark gap impacts on space-time (that is, when the spark occurs) the response from the negative energy sea looks as if it should neutralise the excitation created in the positive energy side (Fig.18). We can't detect the movement of negative energy, and so we only see the impact which it has in our positive energy reality.

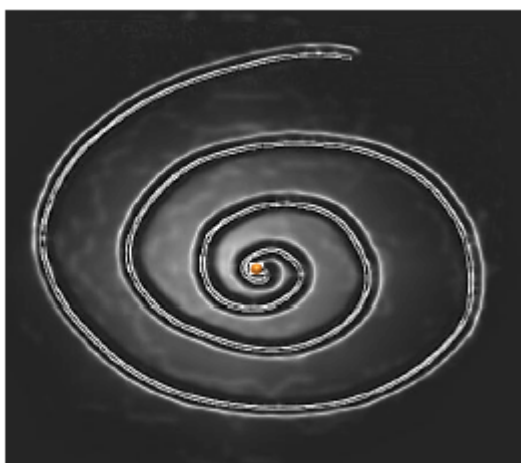

Fig.18

The excitation created on the positive energy side, propagates in all directions.

The reaction from the negative energy sea returns the time-space field to it's original soft state.

The small red ball in the above drawing, is the spark gap which is the door for negative energy to enter our positive energy reality; the negative energy sea will react both before and after the spark occurs.

Referring back to Fig.14, before the spark-gap fires the negative energy will rotate starting from the spark-gap to neutralise the excitation created in the positive energy side (Fig.19a) and when the spark-gap finishes firing, the negative energy will end in the position of the spark gap (Fig.19b).

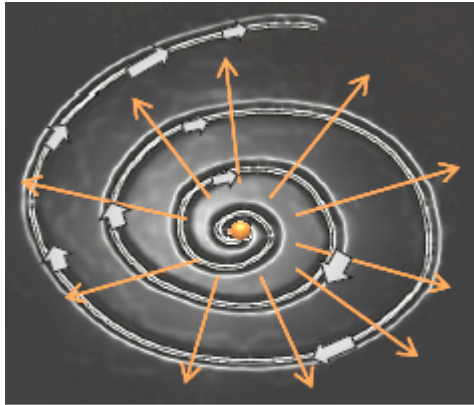

Fig.19a

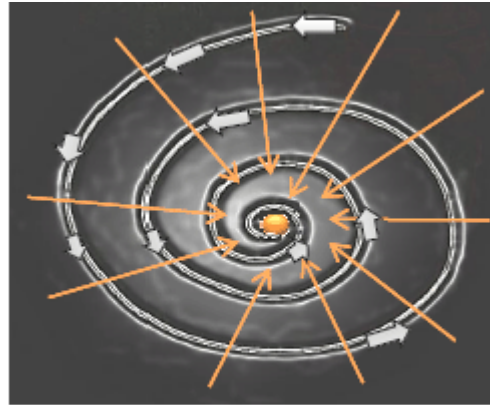

Fig.19b

The Bloch wall area in an ordinary permanent magnet, is the area of electron separation. Let's see how this happens in our extended Tesla Bi-filar Coil. During the first time period, when the capacitor starts discharging across itself to become a parallel L/C circuit, point **A** will provide a maximum voltage while point **B** is the maximum current. The current flow starts from point **A** and finishes at point **B**. The system is now producing magnetic energy and because of the magnetic field increase, the electrons will start from point **B** and flow to point **A** which causes clockwise rotation to neutralise the counter clockwise spin of the voltage electrons, and cold electricity will charge the coil electrically if it is acting as a capacitor, and it will push the current to go back against the voltage by providing a magnetic angular momentum (the clockwise rotation shown in Fig.19a) at point **X** the result is to turn back the voltage electrons, causing strong initial potential electrical energy which increases the electrical energy. Current in cold electricity is the equivalent of voltage in hot electricity. The Bloch wall is the place where negative energy interacts with our E-TBC, in other words when the spark-gap fires, the current will not start immediately because the negative energy will supply a virtual current by providing a CW rotation in the Bloch wall area **X**. This virtual current is a compensator of the real current but it will not absorb the power from the voltage electrons which increase the available potential electrical energy. All this happens before the real current increases to provide the magnetic energy.

Caution: Please be aware that high voltage capacitors have dielectric recovery which stores the electric field for a long time. High voltage capacitors need 5 minutes or more to discharge completely.

Energy is everywhere and in enormous amounts ready to be taken for free. When we do that, we do not reduce the available power because the universe is full of energy, the energy in our universe is the source, physical matter is the energy in a visible form and the energy is in invisible matter form.

The presence of the negative energy sea beside our positive energy reality, raises an important question, namely, why they are separated when they could be united? They are separated to let our universe exist in the way that it does. Negative energy serves our existence because it's designed to be the **under** background energy level for our **foreground** positive energy reality. Our existence is a thin part between those two energetic oceans. Negative energy is extremely active until the point when it appear to be nothing!

We now need to explain another important behaviour of our extended Tesla bifilar coil, namely, it's super conductivity at room temperature.

One of the puzzles in this device is its capability to equal the voltage with the current. The wire of the coil **AB** can receive ambient electrons because it's the surface for the capacitor **CD**; let's examine this surface in Fig.20:

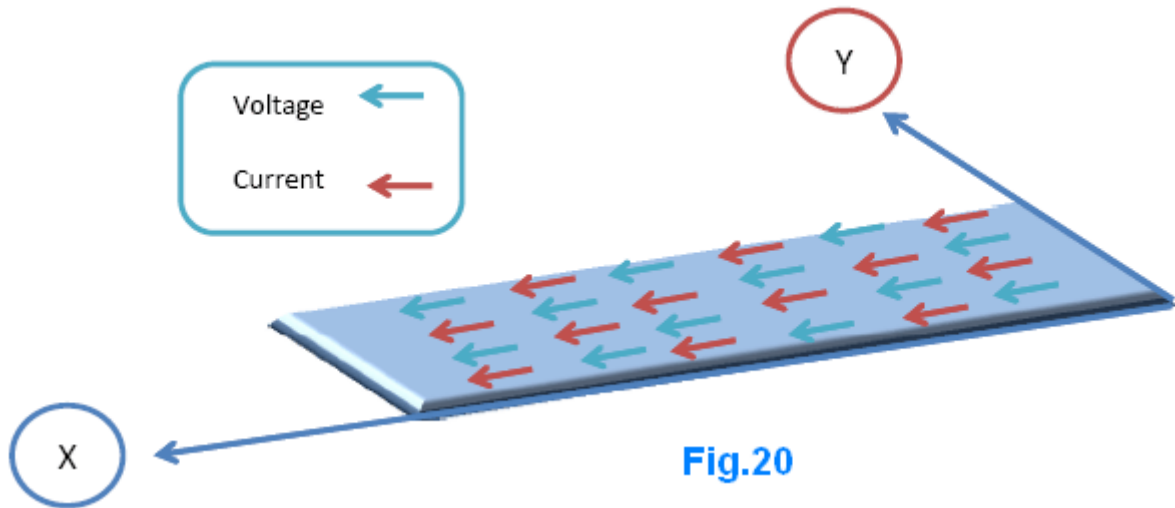
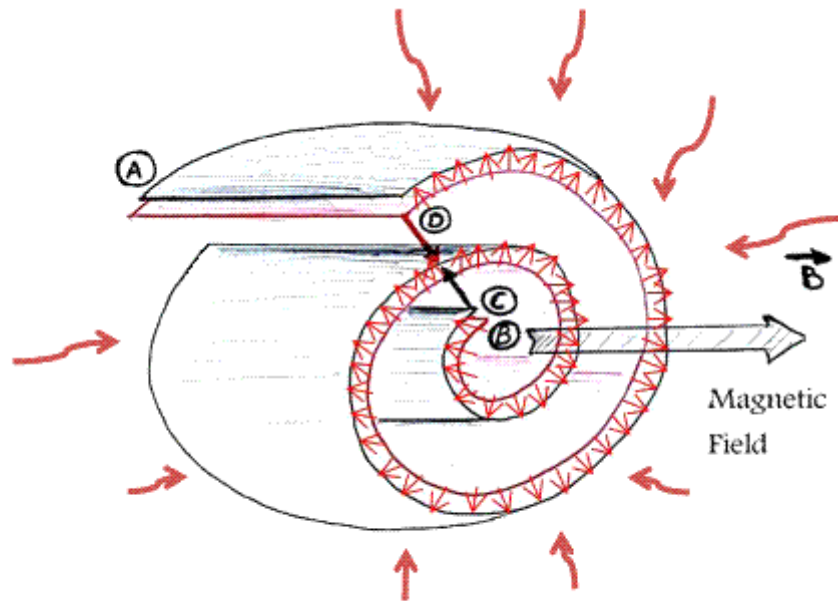

Fig.20

When the capacitor discharges across itself to become a parallel L/C circuit, the induced rotating electric field (with the help of negative energy) creates a difference of voltage between adjacent plates, this voltage according the Gauss law causes **new electrons** to be present in the system.

$$\oint \vec{E} \cdot d\vec{A} = \frac{Q_{enclosed}}{\epsilon_0}$$



(ambient electrons can be taken from the other plate as one of them has to lose electrons)

Fig.21

When ambient electrons enter our system (Fig.21), they increase the power gain across the Y axis (Fig.20). When the current flows inside the extended TBC, parallel currents will be added while parallel voltage will be the same in the Y axis, while in the X axis serial voltage will be added while serial currents will be the same!!

On the Y-axis: sum (I) equals (V)
On the X-axis: sum (V) equals (I)

This system treats the voltages and currents in the same way, the voltages and the currents are physically equal.

When this happens the device squares the electromagnetic flux and becomes a near-unity system in every process which will replicate the electric power according to the working frequency. This is a near-unity system due to the super conductivity at room temperature where the electrons don't face the usual reduction encountered in an ordinary parallel L/C circuit.

A normal L/C circuit cannot produce the super conductivity at room temperature because the exchange between the electric power and the magnetic power must lower one of them in each process. In our extended TBC they are combined in such a way so as to amplify the power in every process, and so the total available electrical energy in each cycle is twice the power available in a charged capacitor which can be seen from the following relationship:

$$\text{Power} = 0.5 \times C \times V^2$$

(consider the similarity between the magnetic and electrical energy in a resonating parallel L/C circuit)

Here, I need to explain the importance of the reactive electric power in the Resonance Energy device, in an alternating electric system where the voltage and current go up and down at the same time (Fig.10). Only active, real power is transmitted and when there is a time shift between current and voltage both reactive and active power are transmitted. When this time shift is 90 degrees ($\pi/2$ degrees) the transmitted real power will be zero as discussed above. This does not mean that there is no power, but it does mean that **we cannot use this power in this alternating form**, we have to transform it into Direct Current so that both current and voltage are united.

Reactive power looks like a skipping rope (Fig.22):

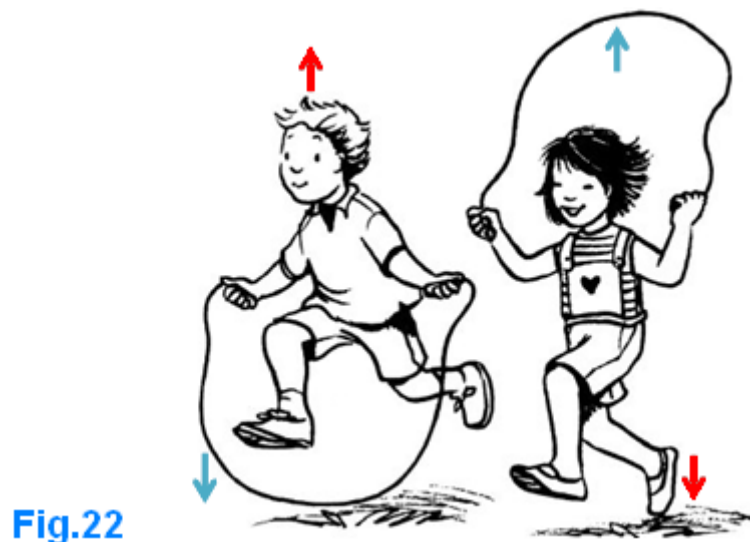

Imagine the **voltage** to be the rope and the children's bodies are the **current**. Reactive power looks like a skipping rope, the active power will not let the kids' bodies move correctly. Reactive power is an essential part of the Resonance Energy device, and a skipping rope is good example which shows how kids go up and down without any problem. This sort of movement exists in our device.

The separation between voltage and current in the Resonance Energy device is crucial for producing and cloning electric power at radio frequency speed. A proper method of collecting and converting the huge available electric energy is needed.

The example given in Fig.22 is important when planning to collect and convert the available electric power. If we simply use a step-down transformer it is highly likely that we will alter the current which will reduce the gained power. With reactive energy, when the voltage is high the current is low. A step-down transformer will lower the voltage but it can't amplify the current as expected! In a normal transformer we amplify the current depending on the available active power ($V \times I$):

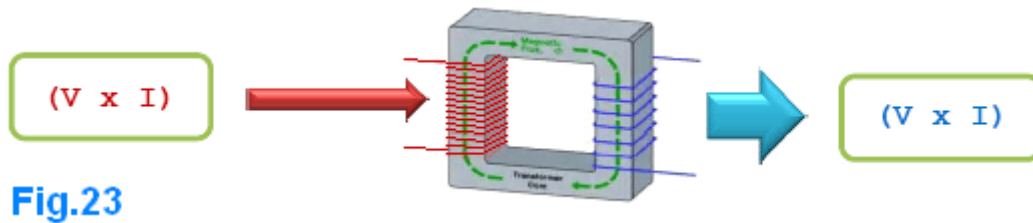

Fig.23

Physically (Fig.23) the **electromagnetic flux** inside the transformer has two components, the electrical component **V** and the magnetic component **I**, for successful transfer of electric power from the primary to the secondary, both of them are needed at the same time. In our case, when **V** is high the product **(V x I)** is low due to the time shift, even if the available power could achieve megawatts!

Another factor which we have to take into consideration, is the high-speed needed to replicate the power, using a transformer to lower the voltage imposes the need for a special transformer core which is able to respond at radio frequencies. These facts have to be taken seriously if we want to collect the available energy effectively.



Fig.24

Personally, I prefer to improve on the use of high-voltage diodes as shown in Fig.24. It is better to use a diode bridge constructed with **fast recovery** high-voltage diodes. Fast recovery diodes have the ability to return to their blocking state very quickly, making it possible for the other half-oscillation to be accumulated in the high-voltage capacitors, each cycle (**up** and **down** in Fig.25) will give power similar to the power available in a charged capacitor given by the following equation $\frac{1}{2} C V^2$.

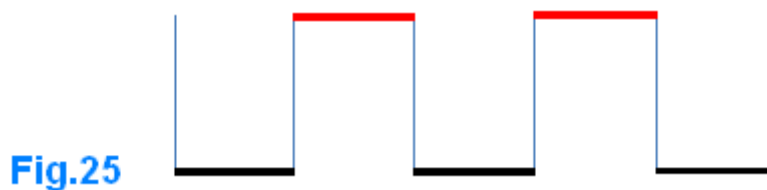

The amazing, energetic behaviour of the extended Tesla Bi-filar Coil make it totally different from an ordinary parallel L/C circuit. Our extended TBC gives twice the frequency of an equivalent parallel L/C circuit. This means that if you form the same inductance with the same capacitance in an ordinary parallel L/C circuit, then that will

produce only half the frequency that the same combination produces with an extended Tesla bifilar coil form!

I have not been able to verify this because I don't have an oscilloscope or a frequency meter. That, of course, is no excuse for not thinking about how the device will act, so the following analysis is an attempt to imagine the energy equation given by Mr. Donald Smith as:

$$\text{Power in one second} = 0.5 \times C \times V^2 \times F^2$$

To simplify things, let us analyse only the voltage. When the capacitor discharges across itself to become a complete parallel LC circuit, at that instant, the magnetic field reaches its maximum value. What makes this system different, is the induced rotating electric field. This field will instantly charge the capacitor with the opposite polarity before the induced current resulting from the collapsing magnetic field can do it. As we learned before, this is the key to energy amplification.

Resonance is the key for energy multiplication, our extended TBC acts like one device, so the passage from the positive cycle to the negative cycle takes no time. In other words, the device has the ability to change its direction of charge instantly. The yellow zone in Fig.26 is absent (compared to a normal parallel L/C circuit), when the energy cycles up and down (Fig.25) the device gives twice the power available in the capacitive side of the extended TBC.

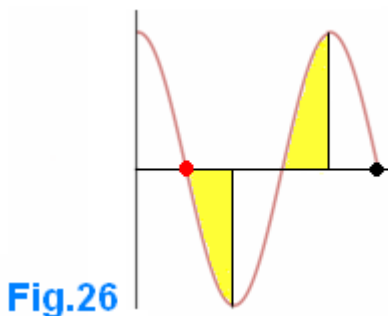

(the cycle in an ordinary L/C circuit is from the red point to the black point. In our device, that is only half of the time which explains why an E-TBC produces twice the frequency when compared to an ordinary parallel combination)

The power in each cycle will be given by:

$$\frac{1}{2} C V^2 \times 2 = C V^2 \dots\dots\dots 1$$

Since the frequency will affect both the voltage and the current we will examine the equation number 1 as follows:

$CV \times V$, the product CV is the quantity of charge available in a charged capacitor, if we divide it by 1 second this will give us the current since Q/T is the current in one second. Let us suppose that the frequency is 3 Hz.

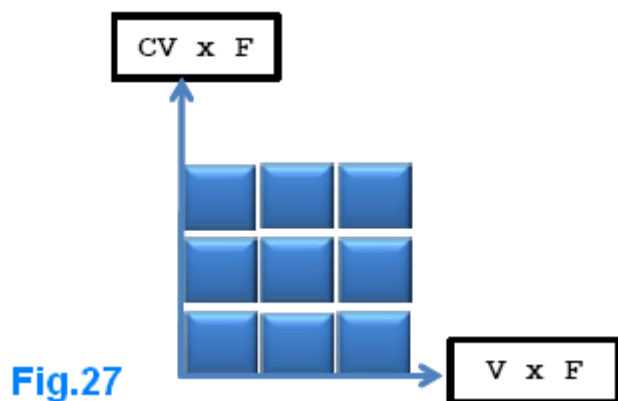

From Fig.27 we can see that the total available power is proportional to 9 which is the square of the given frequency. Each cycle has the power of $C V^2$, the number of cycles in one second gives us the frequency; the frequency will replicate CV which is the current and this will give us $CV \times F$ and replicate the voltage by the product $V \times F$, this analysis is the best explanation of why the voltage equals the current in this system, because $CV \times F$ is the available current and $V \times F$ is the available voltage! This seems strange; how could the product $V \times$

F be the available voltage since the result is very high since we are working with radio frequencies above 20 KHz?

The example given in Fig.23 will help us understand this. The energy formula gives the available DC power when converted from its alternating state; the **electromagnetic** flux will be squared causing amplification of both **current** and **voltage**. In each second, the available power is $CV \times F \times V \times F$, the power obtained depends on the number of turns in coil L2, and the limiting factor is the product $V \times F$ which is a very high number in practical systems. Below this factor, the current is very high being the product $CV \times F!$ This explains why a megawatt sized unit can fit quite easily on a breakfast table and it explains why this device is able to give any required level of energy.

The energetic formula of our extended TBC can now be written as follows:

$$\text{Power in one second} = C \times V^2 \times F^2$$

This equation gives the available power in watts when converted into high-voltage Direct Current. When the device oscillates the power obtained is **pure reactive energy, Volt-Ampere-Reactive (VAR) is present while active electric power (W) is absent in this dynamic state**, Fig.28:

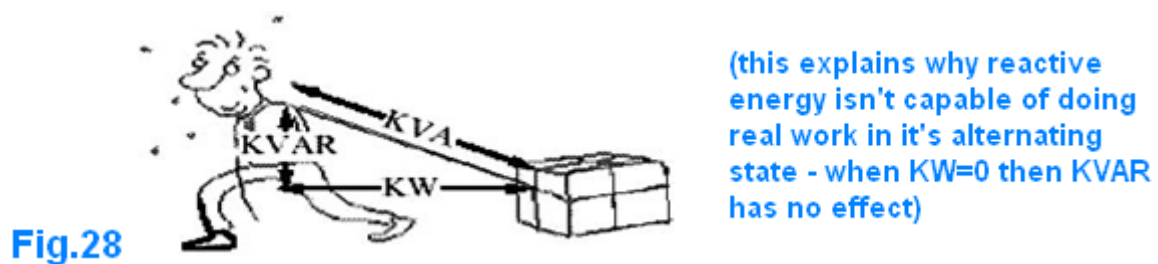

In practical terms, the extended TBC is just a high-voltage capacitor which has the ability to let the current penetrate inside itself, so it has both magnetic and electric specifications.

Practical section

A free-energy device is something which is fascinating, being hasty in wanting to build and test one is common, but that is not good. **High-voltage with high current isn't a game!**, your first mistake may well be your last. If you decide to build this device in your house it is a good idea to use locks and keys and sticking a high-voltage warning symbol on the device is a sensible action.



I am not encouraging you to actually construct the device described here; the above theoretical information provided is the most important section. When the device is fully understood, then taking care when near it will be automatic. This device is a very special Tesla coil, when increasing the voltage in a normal transformer the current drops, **but here the current increases in the same manner as the voltage does!** This device has current equal to the voltage. Resonance will impact both the voltage and the current. The special geometrical design of the extended Tesla Bi-filar Coil, including the flexible position of the spark-gap, produces the needed rotational energetic symmetry between positive and negative energy. As we have already seen, the spark gap opens the door for a massive inflow of electrical energy to be present. **I personally got shocked indirectly from the L2 coil and I certify the risk of this device.**

For construction, the first thing we need is a source of high-voltage. The device can be fed using two different methods as described here. The first is the direct method where the high-voltage power source has the same frequency as the natural resonant frequency of the extended Tesla Bi-filar Coil. The second method is the indirect method; where there is no need to know the frequency of the reactor (active) coil.

The high-voltage power source is needed to feed the extended TBC which is the reactor coil (active coil), Fig.29 shows an easy to build oscillator:

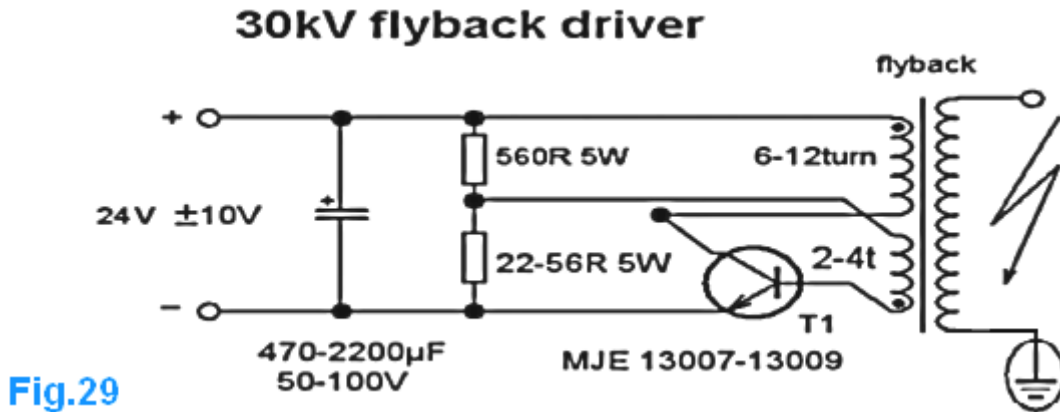

Fig.29

It's better to use a flyback transformer which has a high-voltage diode built into it. Flyback transformers are readily available and cheap. The above circuit diagram is for a flyback transformer, where a high-voltage power source enter our reactor coil via points **A** and **B** (Fig.30):

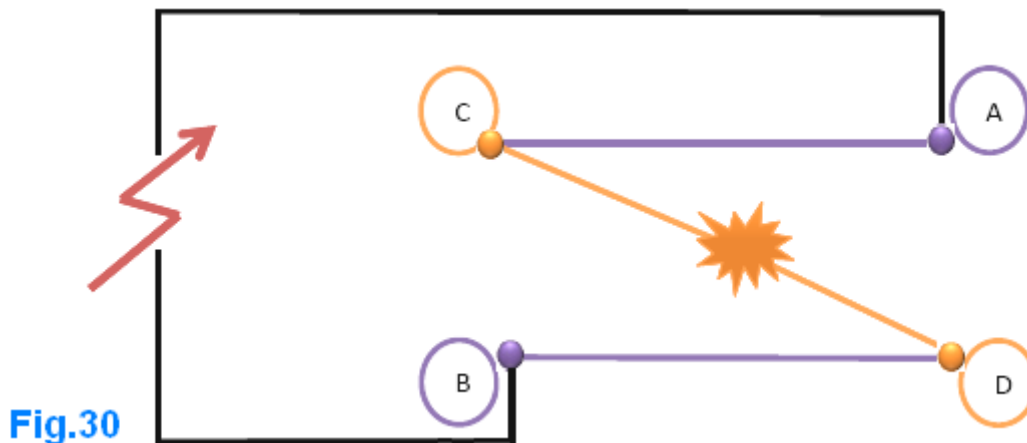
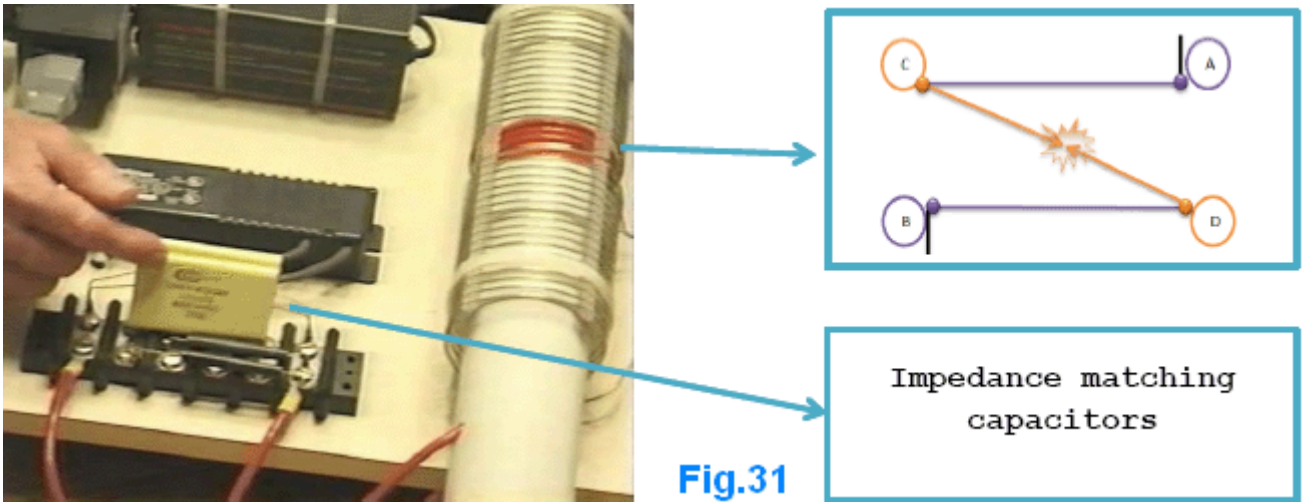

Fig.30

Initially, the capacitor charges up to the value needed by the spark-gap. When the voltage across the electrodes of the spark-gap reaches a high enough value, a spark occurs causing the resistance of the spark-gap to jump from a very high value to a very small value, short-circuiting any power coming from the power source until the natural resonance finishes. The capacitor transforms into a complete coil which has its capacitor built into it. The natural resonance of the TBC is assured when using this method, but it does have some disadvantages. The frequency produced by power supply/spark-gap combination has to be high enough to allow more power to be produced and this calls for a powerful power source. On the other hand, the voltage between the reactor coil **AB** will be **limited** by the distance between the electrodes of the spark-gap. This imposes the need for a large number of turns in the L2 coil.

The output current obtained is directly related to the available voltage between the capacitor plates which form the device between **A** and **B**. We need to bear in mind that the capacitor incorporated inside our extended TBC operates in a dynamic fashion where no displacement current exists.

The direct method of feeding the reactor coil with its own exact natural frequency is the best way to get the most available power, but this creates a real problem as it is not at all easy to find a high-voltage power supply adjustable over the range of frequencies which we want, especially frequencies above 200 KHz. We may require our extended TBC to work above 200 KHz, and for that, we may need impedance-matching capacitors (Fig.31).



The two yellow capacitors seen above are for impedance matching since the working frequency in Don Smith's device was very high, requiring a neon-tube driver to supply it.

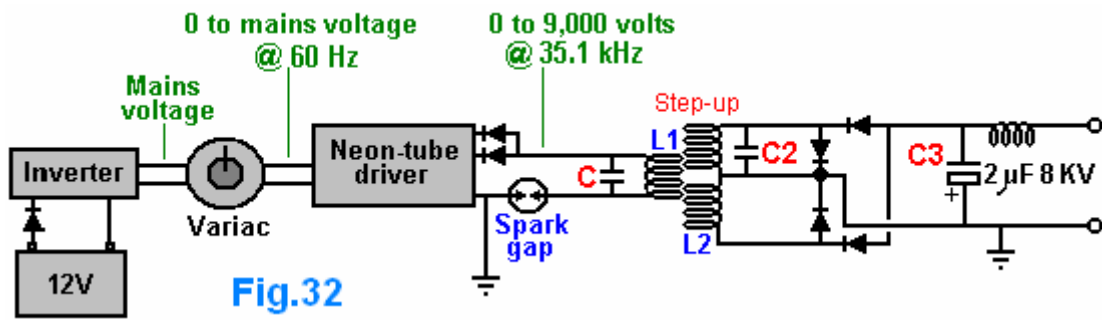

Impedance matching is simply the process of making one impedance look like another; in our situation it is necessary to match the load impedance to the source. For example, if the extended TBC resonates at 2.4 MHz, (this is the load), and the neon-tube driver operates at 35.1 KHz (this is the source) we need to add parallel capacitors to our extended TBC in order to make it resonate at 35.1 KHz.

In practice, you need to short-circuit the points **C** and **D** and measure the inductance of the E-TBC (L2 has to be in place for this measurement). After that, remove the short-circuit and measure the capacitance of the E-TBC. This gives you two values "C" and "L".

The resonance of the Extended –Tesla Bi-filar Coil is given by:

$$F^2 = 1 / (\pi^2 \times LC) \dots\dots\dots (a) \quad \text{The resonant frequency of an E-TBC is double}$$

When you add a capacitor for impedance matching to the extended TBC, the resonance frequency will decrease with the following relationship

$$F^2 = 1 / (4\pi^2 \times L(c+c^*)) \dots\dots\dots (b) \quad \text{where F is the frequency of the source}$$

I believe that we can use the above equation to calculate the value of c* which needs to be added in order to achieve resonance. From equation (b) we could write

$$\frac{1}{F^2} = 4\pi^2 LC + 4\pi^2 LC^* \quad \text{and so we have}$$

$$C^* = \frac{1}{4\pi^2 L} \left(\frac{1}{F^2} - 4\pi^2 LC \right) \dots\dots\dots (c)$$

Using equation (c), we will be able to calculate the needed capacitor for impedance matching; the value obtained is in Farads, and that equation the frequency is in Hz and the inductance in Henries.

When you have the correct C^* value and you power your device up (Fig.33), resonance will not be achieved instantly because the spark gap forms the full L/C parallel circuit only when it fires!!

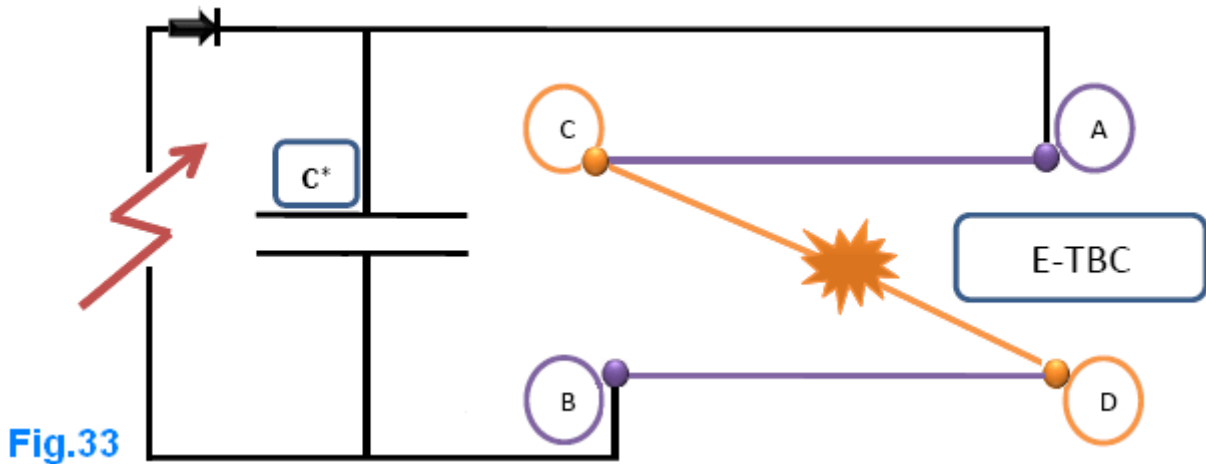

The first thing which happens is the charging of capacitor C^* , after that the capacitor "C" of the extended TBC will be charged until it reaches the voltage needed to make the spark-gap fire. When that happens, the spark-gap has a very low resistance value, making the E-TBC fully formed. At this point, the incoming electric energy from the high-voltage power supply will find a load whose impedance matches its resonant frequency. This, in turn, produces the maximum possible voltage across inductance L of the E-TBC. Further, the resulting electromagnetic field will increase cycle by cycle causing the device to resonate fully after a very short time.

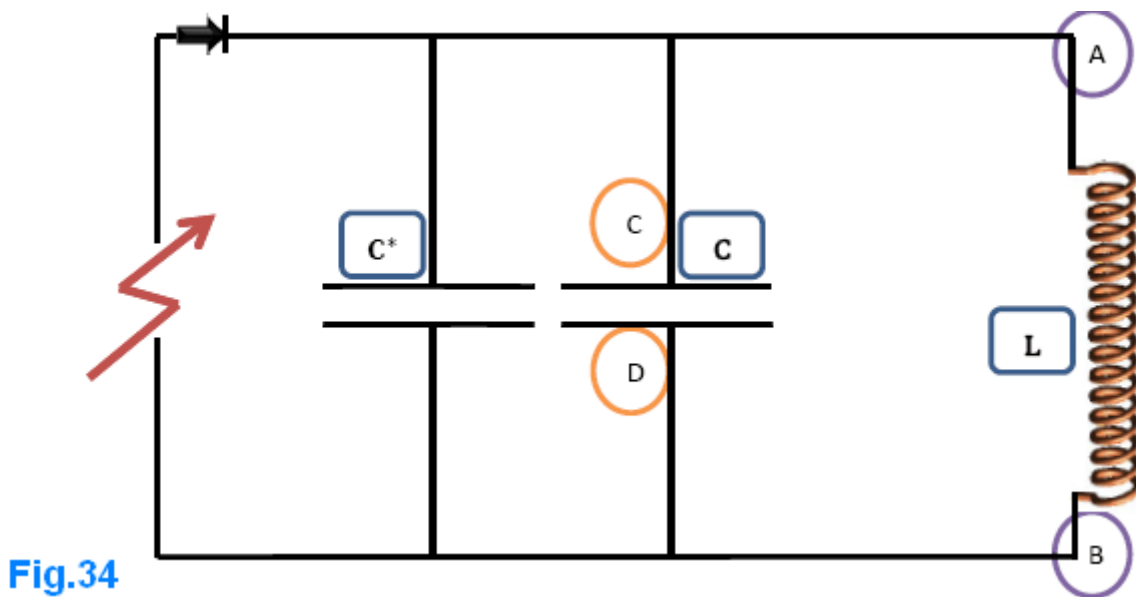

This is the equivalent circuit when the spark-gap fires

Constructing the extended TBC

The extended Tesla Bi-filar Coil is just a high-voltage capacitor which has a magnetic behaviour. So, it is both a capacitor and coil at the same time. Constructing this device is relatively simple. You need two lengths of aluminium foil, each 1.2 meters long (later I will explain the possibilities of modifying the characteristics of an extended TBC). Because it is a capacitor, you need 3 pieces of polyethylene sheet, each 1.3 meters long.

To construct a high voltage capacitor usually you need 2 pieces of polyethylene sheet but it's better to use 3 pieces since we are working with a high voltage (Fig.35), this will depend on your skills in constructing a high voltage capacitor.

You need welding rods to insure the electrical conductivity of the aluminium foils, Fig.36 indicates how to do that. Actually the best length and width of aluminium foil need some experimentation; you have to establish the

positions of the magnetic and electrical points (Fig.37). **A** and **B** are the magnetic points (coil) while **C** and **D** are the electric points (capacitor).

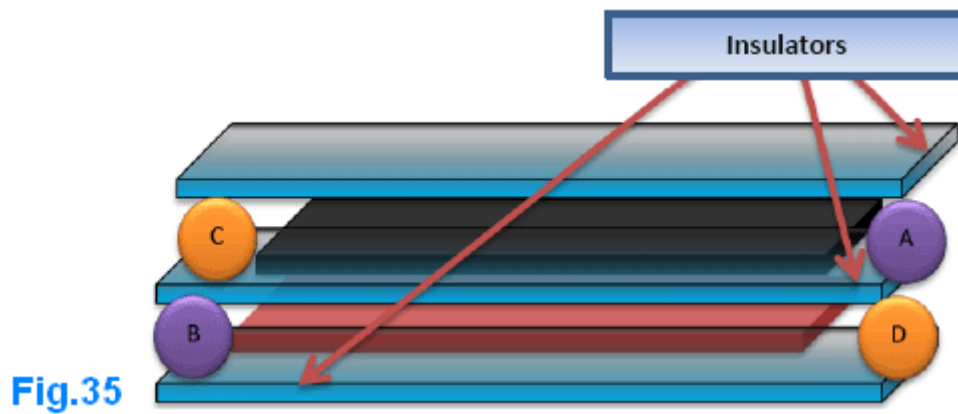

Fig.35

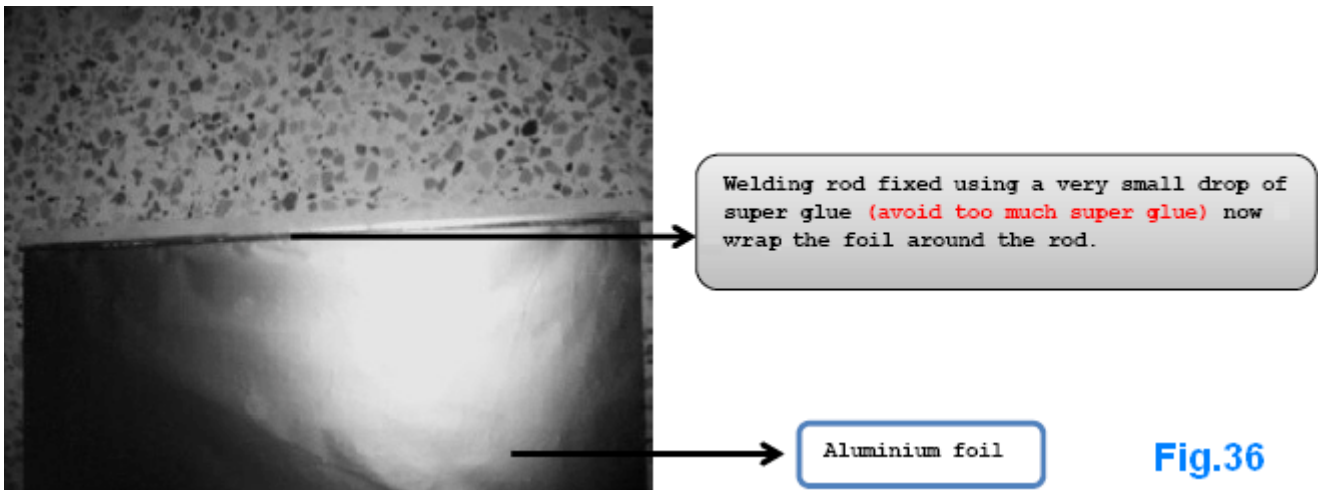

Fig.36

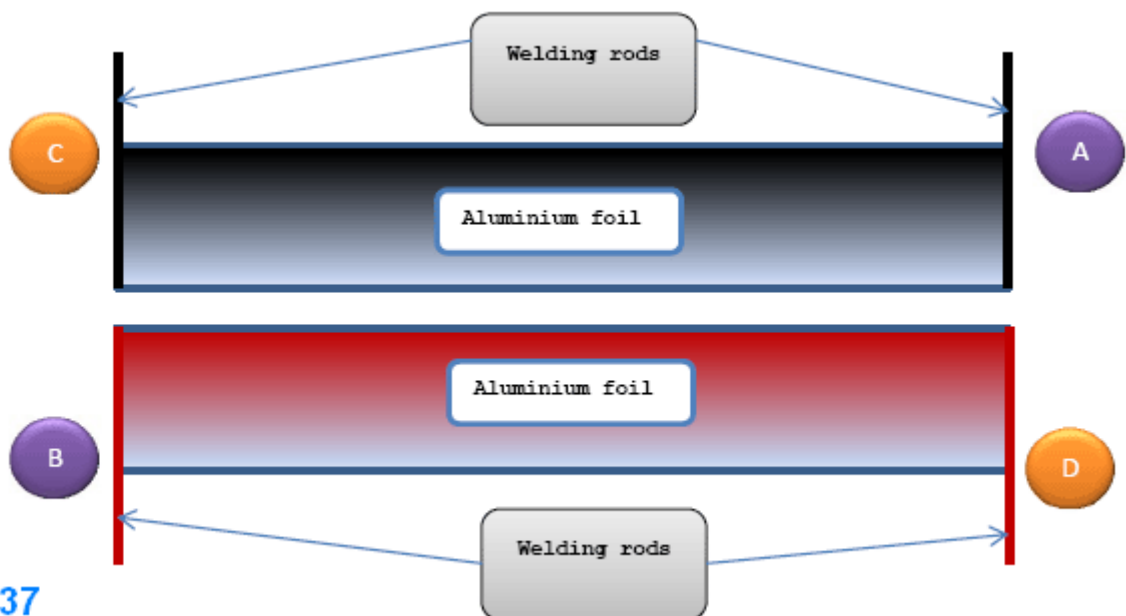
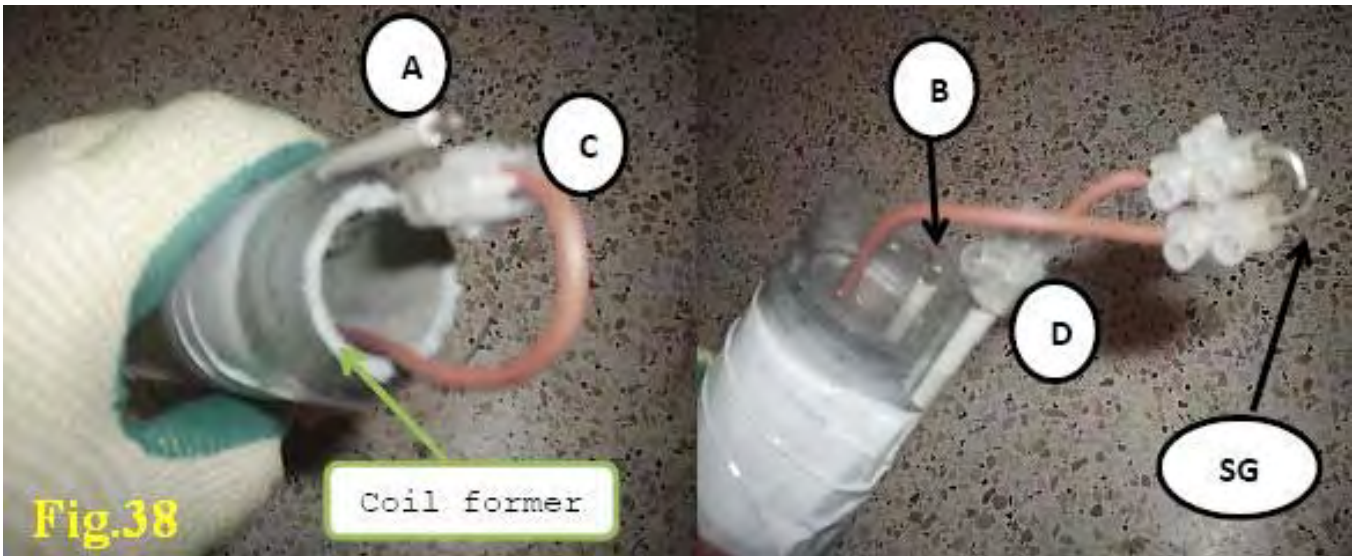

Fig.37

The E-TBC need a coil former for it to be wound on it (Figure 38)



The following photo shows the dimensions used in the prototype (Fig.39)



The width of aluminum foil is 10 cm; the length of each capacitor plate is 120 cm

Fig.39

Internal arcing is a common problem with high-voltage capacitors (Fig.40)

Notice the cutoff along the plastic tube; this will help in penetration the aluminum foils, the points C and B will be inside the tube but A and D will be outside, now firmly turn the plastic tube to form your E-TBC.

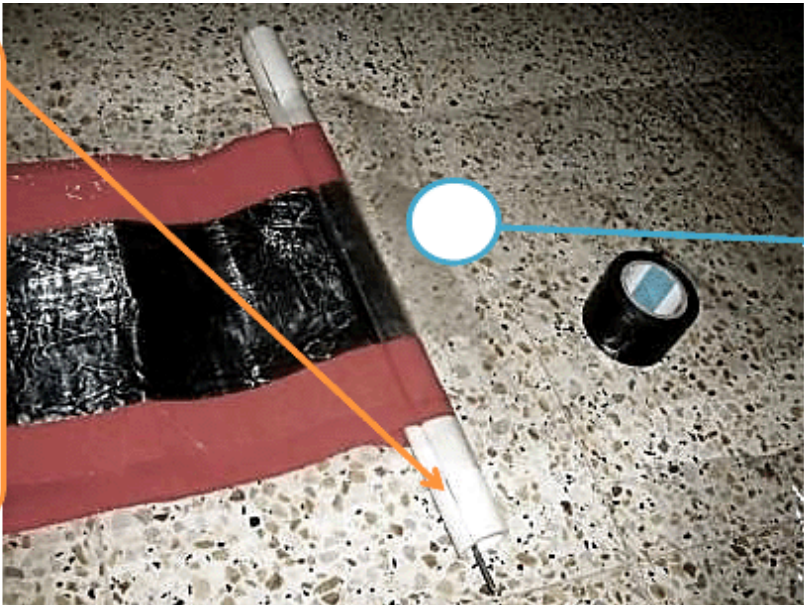

An internal arcing is a common problem in a high voltage capacitor; a good isolation is needed as well as a good insulator.

Fig.40

The best combination between the length and the width of an extended TBC has a major influence on the electric energy obtained at the L2 coil (the reactant coil). For example, the electric arcing experienced at the L2 coil using the E-TBC shown in Fig.41, was very weak, the length shown by the black arrow is very much greater than the width (orange arrow), this give a weak magnetic flux due to the small coil inductance, the coil inductance is very important because it will transform the replicated power into electromagnetic flux.



The reactant coil (L2):



The coil length is about 25cm as shown in Figure 42, the diameter is 6 cm, and the thickness of the wire is 1.18 mm (AWG #17 or swg 18) and the number of turns is about 200. Fig.43 shows some nice sparks from L2 coil:



The spark shown above is very strong but it can't burn through thin paper! This proves that the electric energy obtained is reactive, and so it can't do work as it is. Converting a high-voltage reactive electric power into Direct Current isn't easy to achieve. Working with a voltage over 10KV is really dangerous, in my device I had about 40KV of reactive power which to be converted.

Ideas:

To solve this problem let's think again about the energy equation of our extended TBC. The idea is to work with a step-down method rather than using the step-up technique.

The energy equation can be written like this: **Power in one second = CVF x VF**

CVF is the available current in one second since C is the capacitance value of the E-TBC, V is the voltage used, and F is the resonance frequency.

VF is the limit value when stepping up the voltage across the L2 coil, the gained electric power goes up proportional to the voltage value across L2, when achieving VF the total obtained power will be exactly: $C V^2 F^2$ which is a very high power level. I know that this can be confusing, but this system has equal voltage and current. When stepping up the voltage, the current remains constant because it depends on the product **CVF**. We could increase the voltage by adding more turns to the L2 coil, when doing this the current is the same but the available electric energy will be given by: **Power in one second = CVF x V***

Where **V*** is the voltage across L2.

Using this new equation will help us a great deal in determining the voltage needed across the L2 coil in order to achieve the required electric power.

Example:

Imagine you have the following working conditions:

C = 10 nF

V = 30 KV

F = 100 KHz

You need a power of 30 KW, what L2 voltage is needed to achieve this power level?

Using the previous relation will give us:

$$30,000 = CVF \times V^*$$

$$30,000 = 10 \times 10^{-9} \times 30 \times 10^3 \times 100 \times 10^3 \times V^*$$

$$30,000 = 30 \times V^* \implies V^* = 1,000 \text{ volts}$$

to obtain 30 KW you only need 1000 volts across the L2 coil. To achieve this power level **you need direct resonance**, feeding the E-TBC with a high-voltage only, without direct resonance, will not give this result since the voltage across the coil of the E-TBC will be limited by the electrode separation of the spark gap.

The voltage **V** across the E-TBC is very important here because the product **CVF** is the current obtained using the reactant coil (L2). The working frequency **F** is important too. Similar to an ordinary transformer, if we want to use the step-down method effectively, we have to think about using too many turns when winding the E-TBC. When designing an E-TBC, it is important to think about the length of the capacitor plates because the length between **B** and **D** will give the total value of the induced voltage between the capacitor plates which increase the electromagnetic flux (Figure 44).

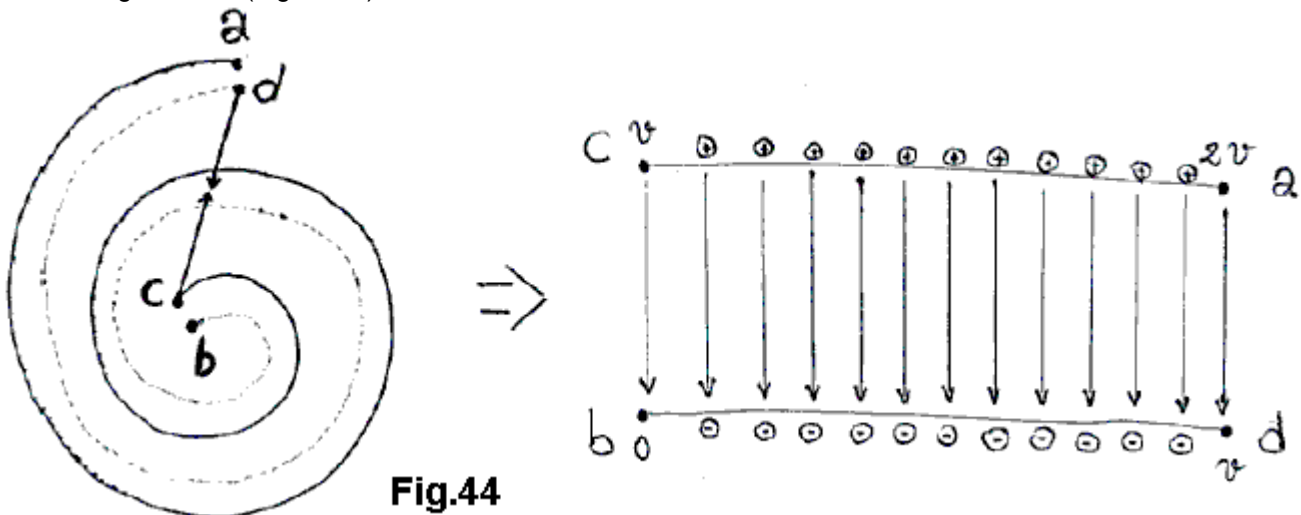

Fig.44

A simple diagram of the resonance energy device can be like the following drawing (Fig.45):

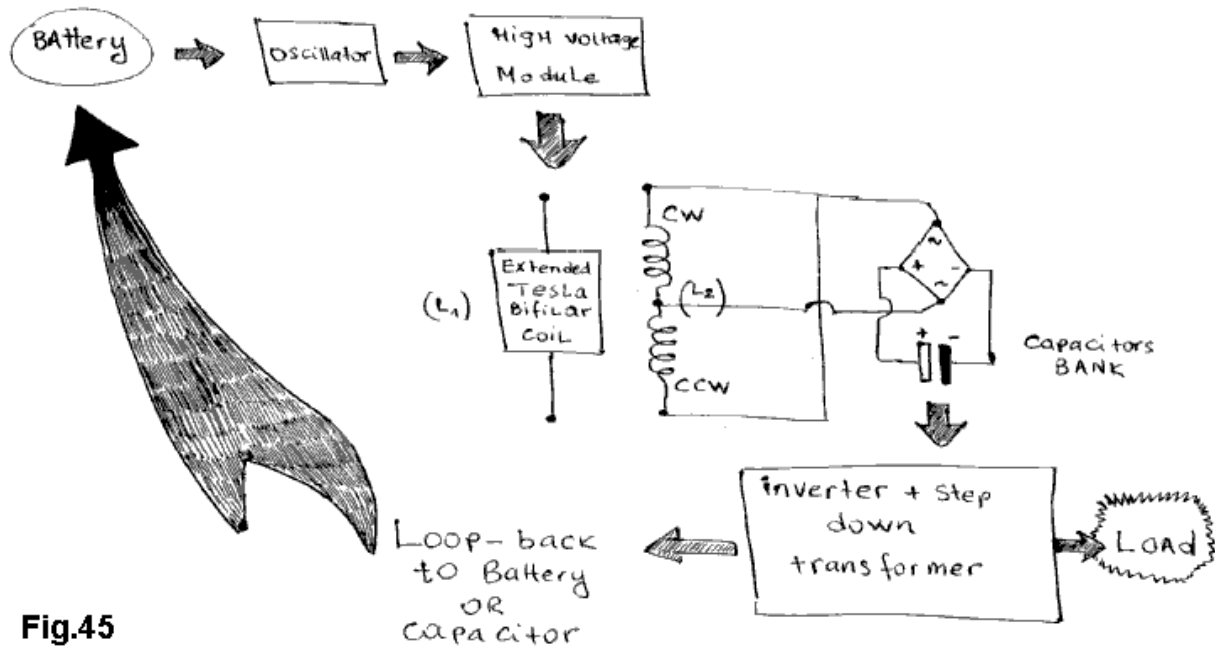

Fig.45

When converting the reactive electric power from the L2 coil to Direct Current and stepping down the energy obtained to the mains voltage and frequency (for example, 220V, 50Hz), the current will be boosted yet again.

Some applications may not need an inverter. An electric heater can be fed directly from the capacitors banks but we have to prevent the Alternating Current coming from L2 to enter the heater by using another high inductance coil.

Another idea about increasing the capacitive side of the extended TBC is to use etched aluminium foil to increase the surface area. The foil can be treated chemically using high-voltage. The result is shown in Fig.46:

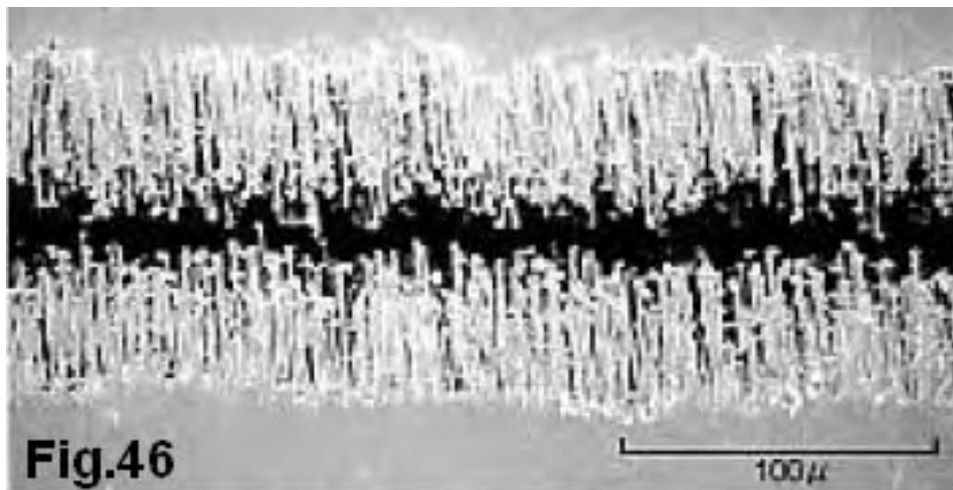

Fig.46

Maybe this is the technique used by Donald Smith to avoid the need for an earth connection. I have already mentioned about using negative energy to avoid the earth connection requirement in the Resonance Energy device but I can't guarantee that this is the method used by Donald Smith.

Any questions, or suggestions are welcome via my e-mail: hopehope3012 (at) gmail (dot) com