



US006419815B1

(12) **United States Patent
Chambers**

(10) **Patent No.: US 6,419,815 B1**
(45) **Date of Patent: Jul. 16, 2002**

(54) **METHOD FOR PRODUCING
ORTHOHYDROGEN AND/OR
PARAHDROGEN**

FOREIGN PATENT DOCUMENTS

JP 9071886 3/1997 C25B/1/04
WO 9809001 3/1998 C25B/1/04

(75) Inventor: **Stephen Barrie Chambers**, Calgary
(CA)

OTHER PUBLICATIONS

Use of Hydrogen in Welding Engineering in Former Times and Today, M. Suban et al., 11 pages (date unknown) (No Date).

(73) Assignee: **Xogen Power Inc.**, Calgary (CA)

<http://www.keelynet.com/energy/meyerx.htm>, Notice of Death of Stanley Meyer, visited Jun. 19, 2001.

(*) Notice: Subject to any disclaimer, the term of this patent is extended or adjusted under 35 U.S.C. 154(b) by 0 days.

<http://www.padrak.com/ine/FEONBRTV.html>, Free Energy As Seen on British T.V., visited Jun. 19, 2001.

(21) Appl. No.: **09/608,316**

<http://www.non-wave.com/llla.htm>, Energy Revolution, visited Nov. 1, 2001.

(22) Filed: **Jun. 30, 2000**

International Search Report dated Nov. 9, 1999.

Related U.S. Application Data

Primary Examiner—Donald R. Valentine

(74) *Attorney, Agent, or Firm*—Stoel Rives LLP

(63) Continuation of application No. 09/105,023, filed on Jun. 26, 1998, now Pat. No. 6,126,794.

(57) **ABSTRACT**

(51) **Int. Cl.**⁷ **C25C 1/02**; C25B 1/02

An apparatus for producing orthohydrogen and/or parahydrogen. The apparatus includes a container holding water and at least one pair of closely-spaced electrodes arranged within the container and submerged in the water. A first power supply provides a particular first pulsed signal to the electrodes. A coil may also be arranged within the container and submerged in the water if the production of parahydrogen is also required. A second power supply provides a second pulsed signal to the coil through a switch to apply energy to the water. When the second power supply is disconnected from the coil by the switch and only the electrodes receive a pulsed signal, then orthohydrogen can be produced. When the second power supply is connected to the coil and both the electrodes and coil receive pulsed signals, then the first and second pulsed signals can be controlled to produce parahydrogen. The container is self-pressurized and the water within the container requires no chemical catalyst to efficiently produce the orthohydrogen and/or parahydrogen. Heat is not generated, and bubbles do not form on the electrodes.

(52) **U.S. Cl.** **205/628**; 205/637; 205/341

(58) **Field of Search** 205/341, 628,
205/637

(56) **References Cited**

U.S. PATENT DOCUMENTS

3,262,872 A	7/1966	Rhodes et al.	204/272
3,310,483 A	3/1967	Rhodes	204/268
3,311,097 A	3/1967	Mittelstaedt	123/119
3,954,592 A *	5/1976	Horvath	204/272 X
3,980,053 A	9/1976	Horvath	
4,014,777 A	3/1977	Brown	204/270
4,081,656 A	3/1978	Brown	219/137.31
4,107,008 A *	8/1978	Horvath	205/628 X
4,184,931 A	1/1980	Inoue	204/129
4,316,787 A	2/1982	Themy	204/242
4,384,943 A	5/1983	Stoner et al.	
4,394,230 A *	7/1983	Puharich	204/266 X
4,470,894 A	9/1984	Dyer	

(List continued on next page.)

19 Claims, 10 Drawing Sheets

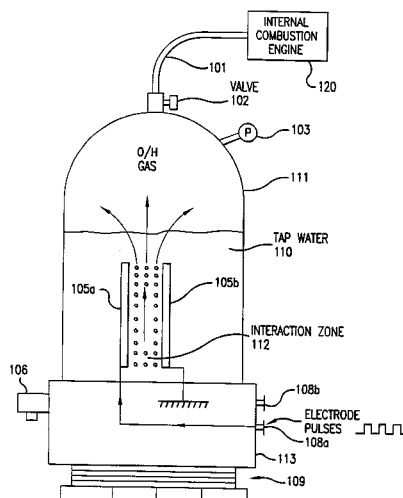

U.S. PATENT DOCUMENTS

4,599,158 A	7/1986	Ofenloch	204/228	5,399,251 A	3/1995	Nakamats	
4,755,305 A	7/1988	Fremont et al.		5,435,894 A	7/1995	Hayakawa	
4,798,661 A	1/1989	Meyer	204/228	5,599,437 A	2/1997	Taylor et al.	
4,936,961 A	6/1990	Meyer	204/157.5	5,614,078 A	3/1997	Lubin et al.	
5,205,944 A	4/1993	Sawamoto et al.		5,632,870 A	5/1997	Kucheroy	204/278
5,304,289 A	4/1994	Hayakawa		5,695,650 A	12/1997	Held	
5,324,398 A	6/1994	Erickson et al.		5,698,107 A	12/1997	Wurzburger et al.	
5,376,242 A	12/1994	Hayakawa		6,126,794 A	* 10/2000	Chambers	204/230.5

* cited by examiner

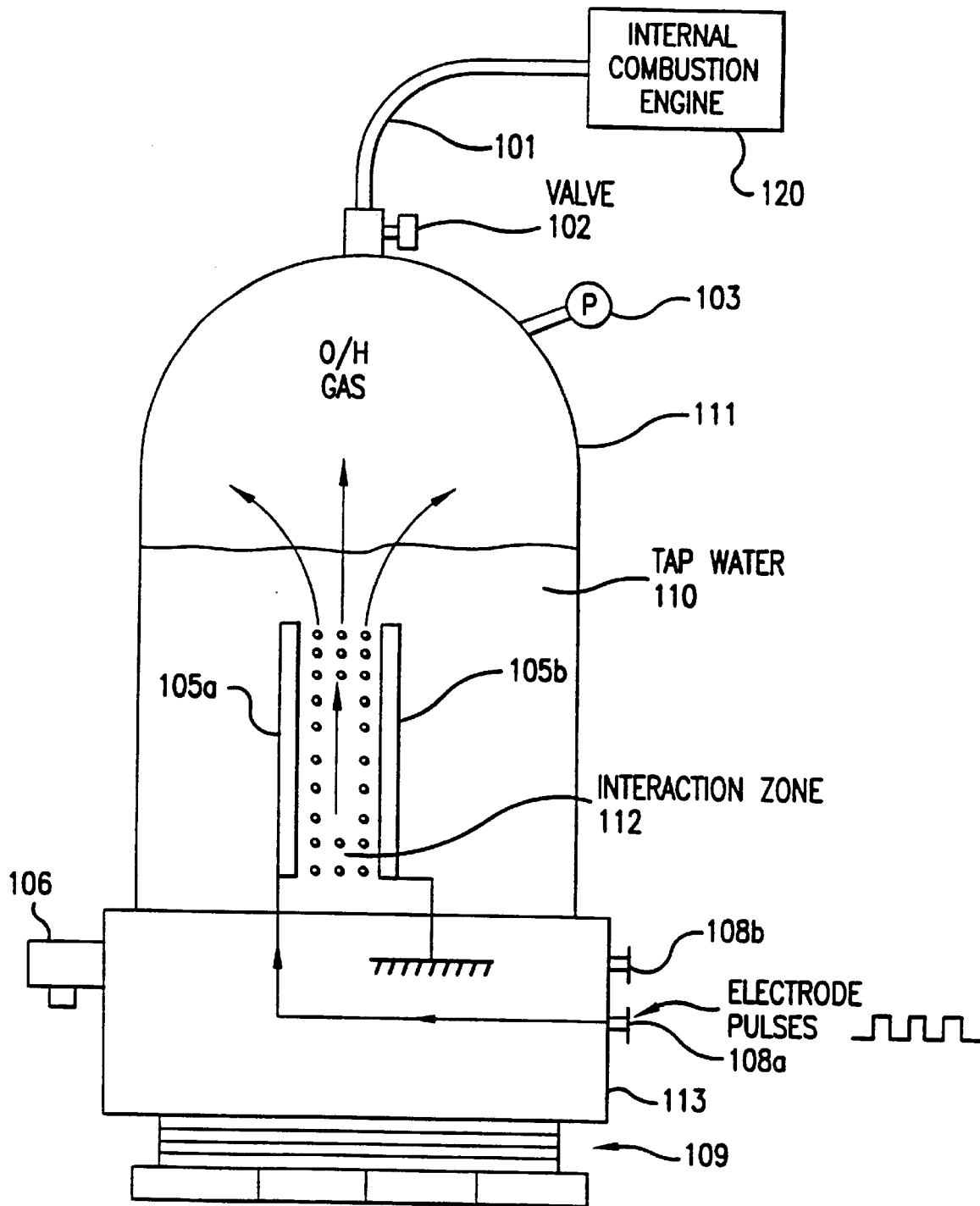

FIG. 1

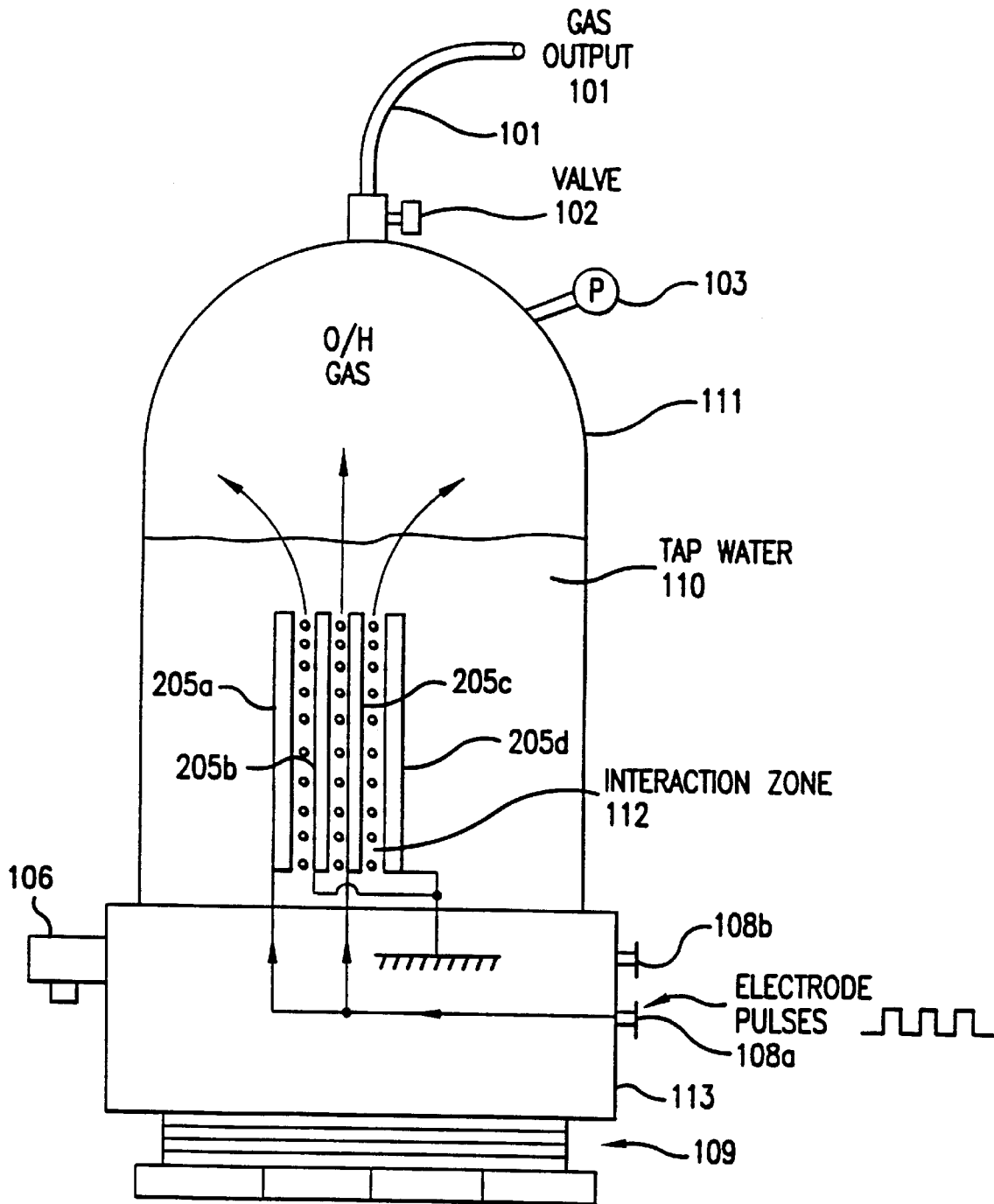

FIG. 2

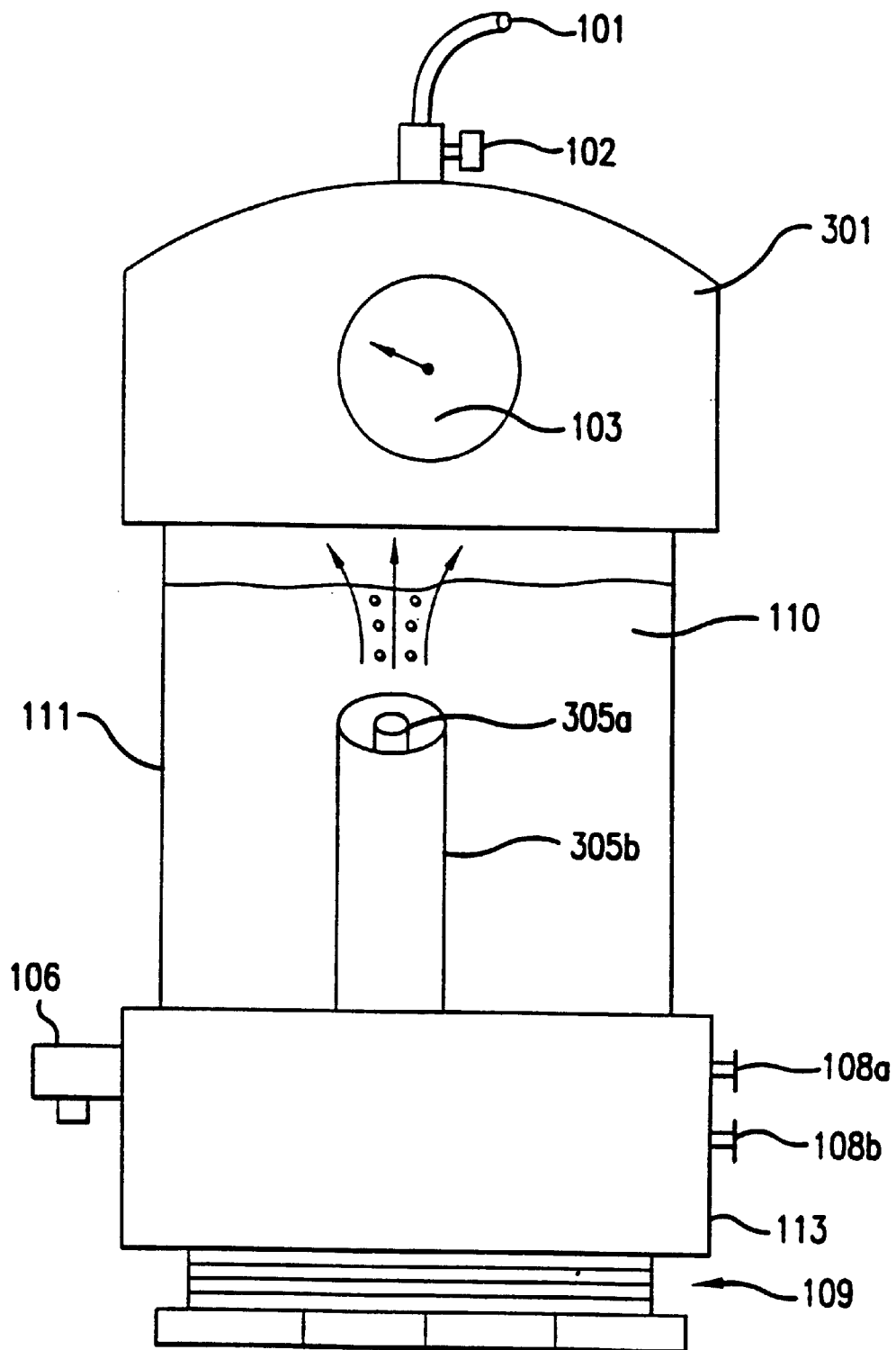
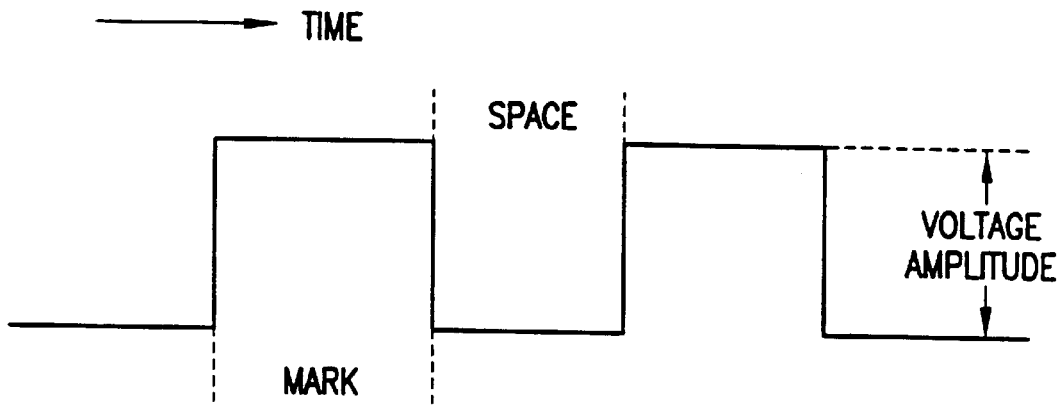
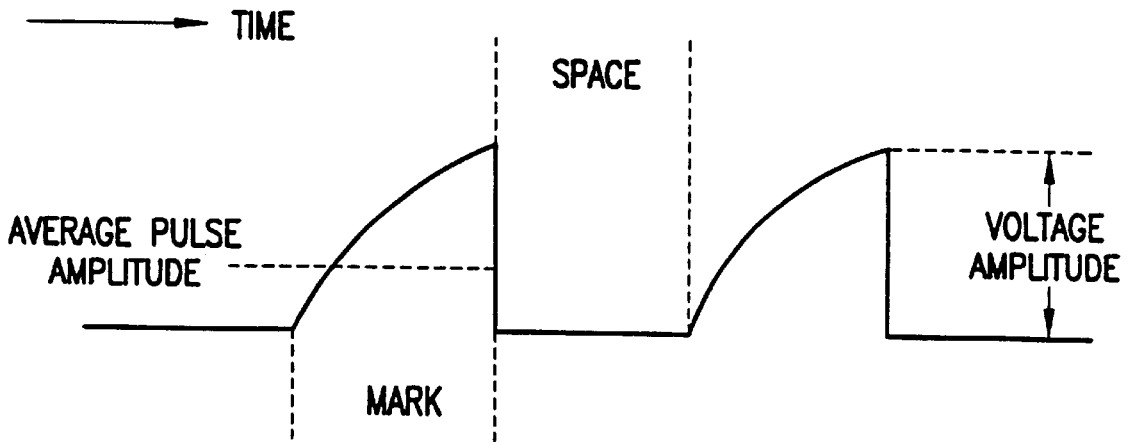

FIG. 3



SQUARE WAVE WITH 1:1 MARK-SPACE RATIO

FIG. 4a



SAWTOOTH WAVE WITH 1:1 MARK SPACE RATIO
A SAWTOOTH WAVE WILL ONLY REACH PEAK VOLTAGE
AT THE END OF THE PULSE DURATION

FIG. 4b

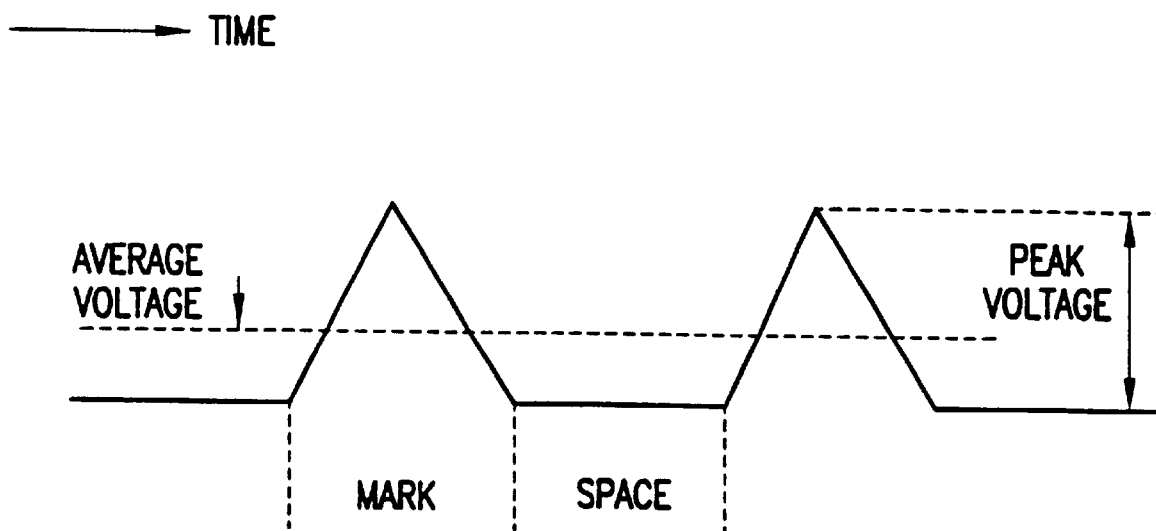

TRIANGULAR WAVE WITH 1:1 MARK SPACE RATIO
A TRIANGULAR WAVE HAS A LOW PEAK VOLTAGE

FIG. 4c

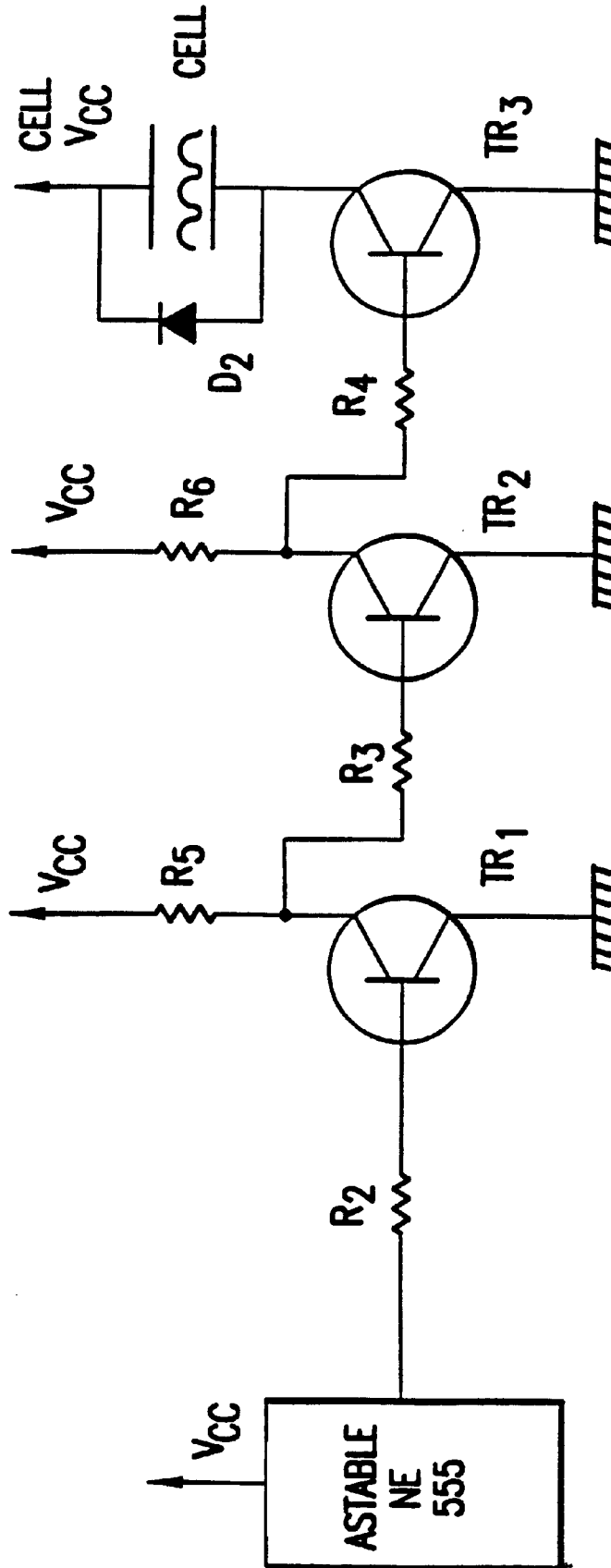

FIG.5

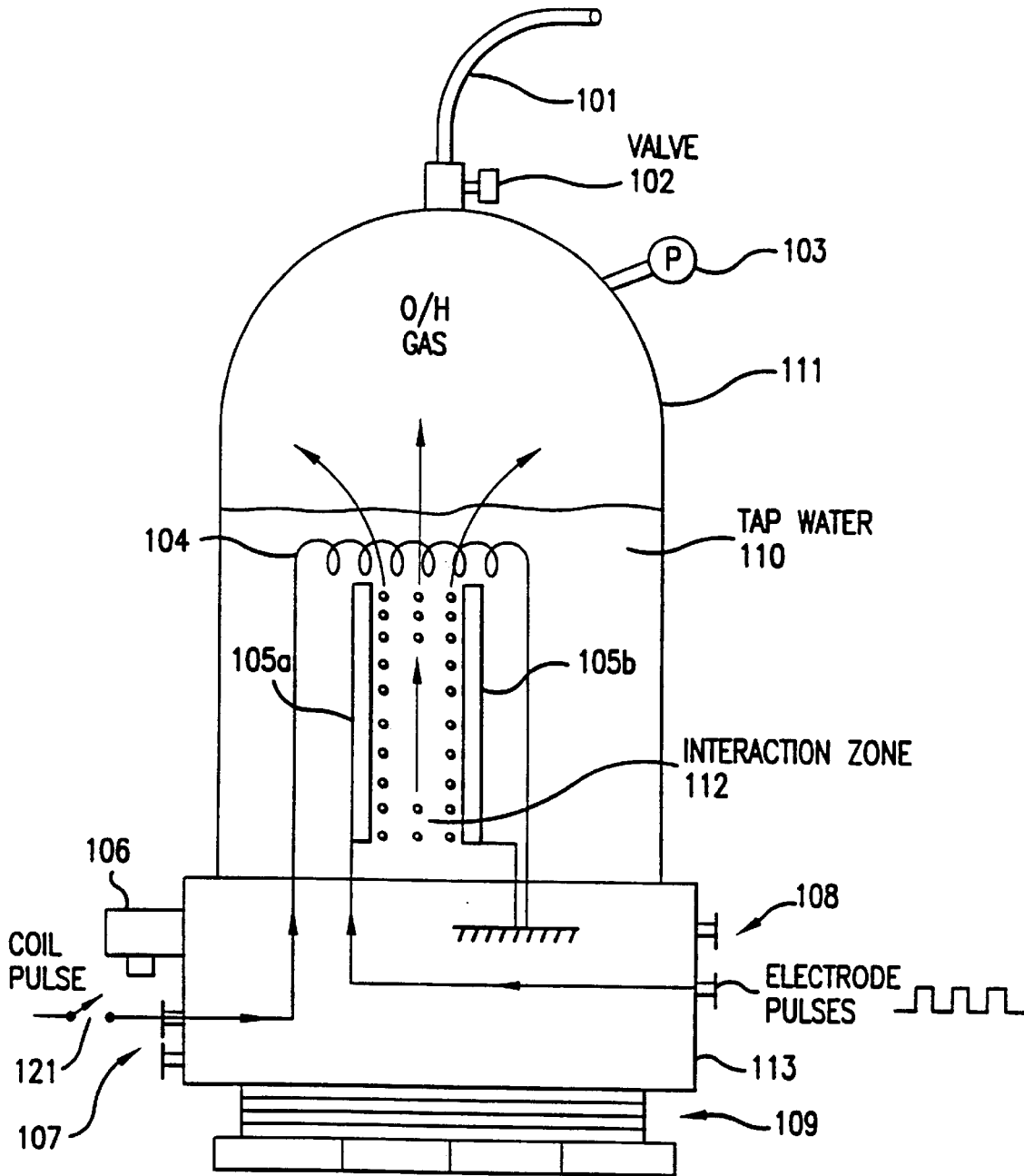

FIG. 6

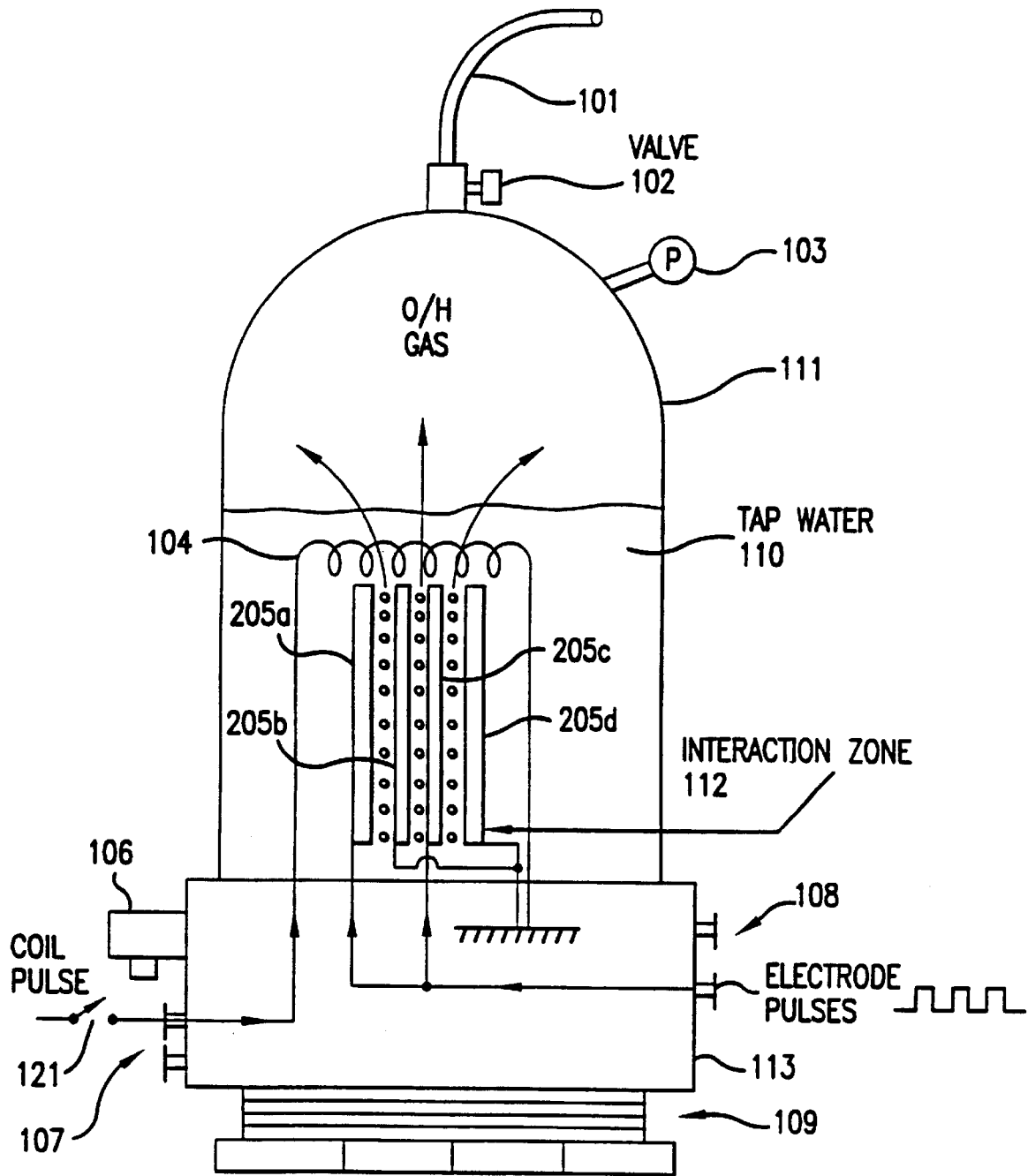

FIG.7

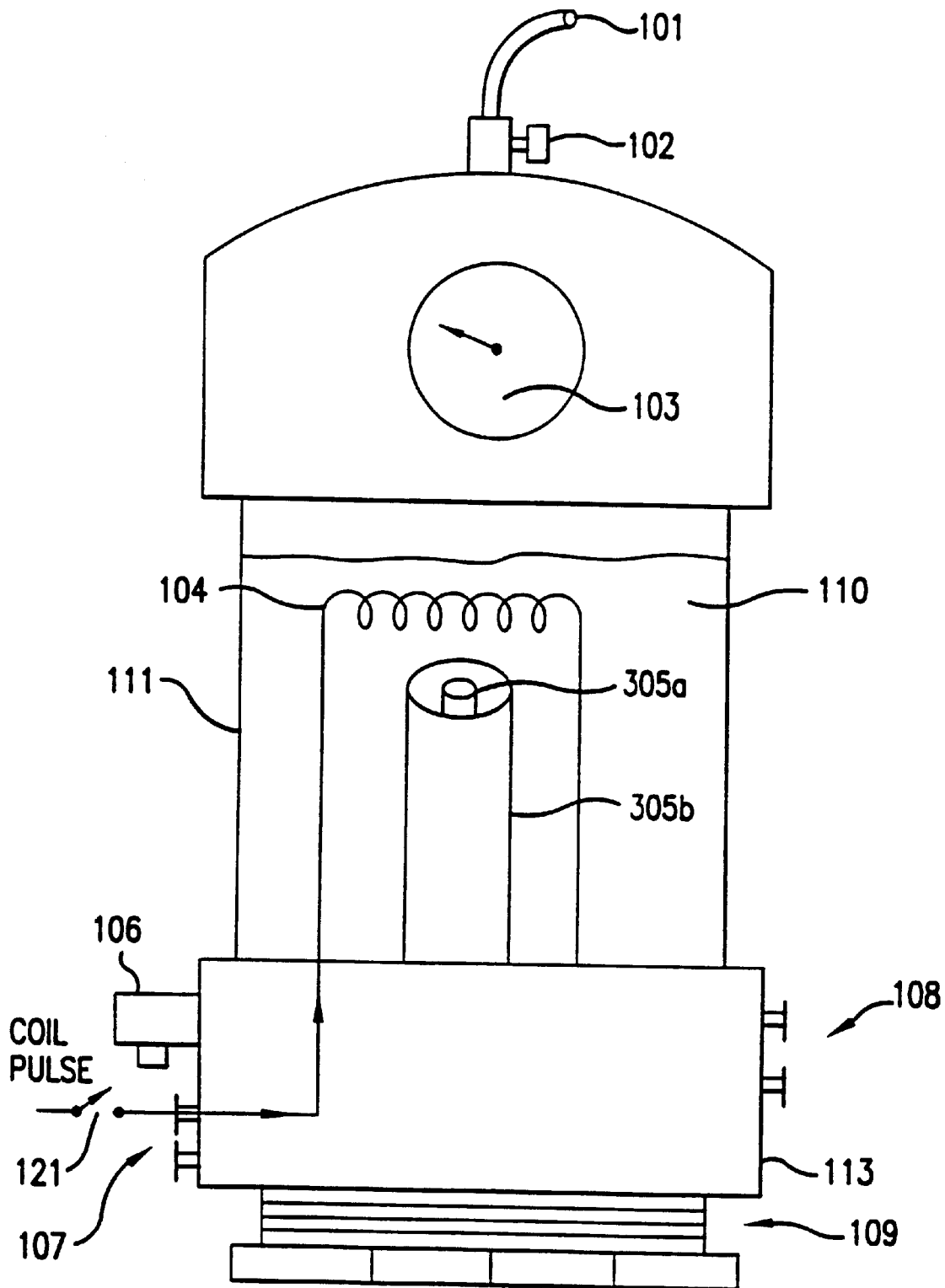
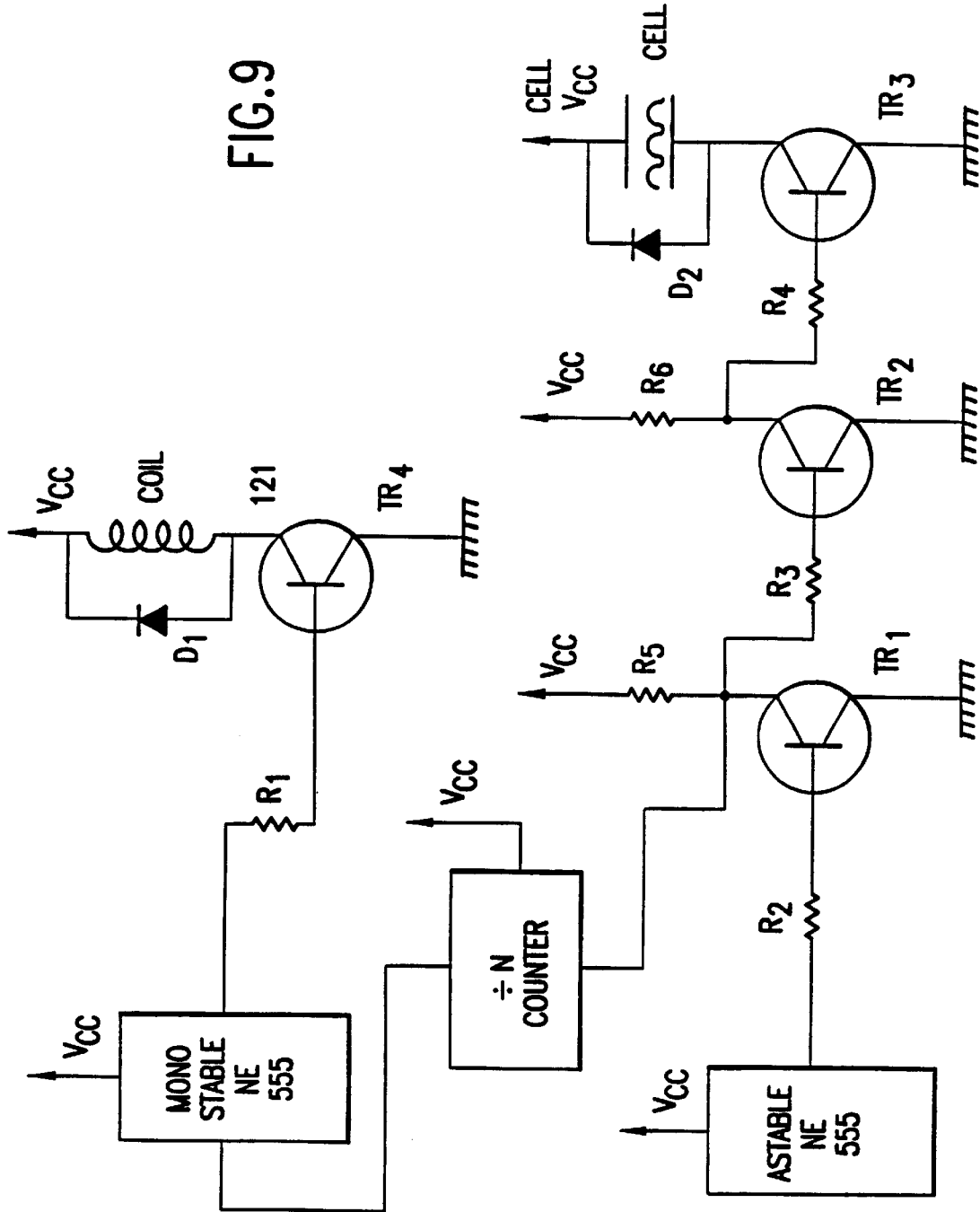

FIG. 8

FIG. 9



1

METHOD FOR PRODUCING ORTHOHYDROGEN AND/OR PARAHYDROGEN

RELATED APPLICATIONS

The present application is a continuation of application Ser. No. 09/105,023, filed Jun. 26, 1998, now U.S. Pat. No. 6,126,794, issued Oct. 3, 2000.

TECHNICAL FIELD

The present invention relates to methods for producing orthohydrogen and parahydrogen.

BACKGROUND OF THE INVENTION

Conventional electrolysis cells are capable of producing hydrogen and oxygen from water. These conventional cells generally include two electrodes arranged within the cell which apply energy to the water to thereby produce hydrogen and oxygen. The two electrodes are conventionally made of two different materials.

However, the hydrogen and oxygen generated in the conventional cells are generally produced in an inefficient manner. That is, a large amount of electrical power is required to be applied to the electrodes in order to produce the hydrogen and oxygen. Moreover, a chemical catalyst such as sodium hydroxide or potassium hydroxide must be added to the water to separate hydrogen or oxygen bubbles from the electrodes. Also, the produced gas must often be transported to a pressurized container for storage, because conventional cells produce the gases slowly. Also, conventional cells tend to heat up, creating a variety of problems, including boiling of the water. Also, conventional cells tend to form gas bubbles on the electrodes which act as electrical insulators and reduce the function of the cell.

Accordingly, it is extremely desirable to produce a large amount of hydrogen and oxygen with only a modest amount of input power. Furthermore, it is desirable to produce the hydrogen and oxygen with "regular" tap water and without any additional chemical catalyst, and to operate the cell without the need for an additional pump to pressurize it. It would also be desirable to construct the electrodes using the same material. Also, it is desirable to produce the gases quickly, and without heat, and without bubbles on the electrodes.

Orthohydrogen and parahydrogen are two different isomers of hydrogen. Orthohydrogen is that state of hydrogen molecules in which the spins of the two nuclei are parallel. Parahydrogen is that state of hydrogen molecules in which the spins of the two nuclei are antiparallel. The different characteristics of orthohydrogen and parahydrogen lead to different physical properties. For example, orthohydrogen is highly combustible whereas parahydrogen is a slower burning form of hydrogen. Thus, orthohydrogen and parahydrogen can be used for different applications. Conventional electrolytic cells make only orthohydrogen and parahydrogen. Parahydrogen, conventionally, is difficult and expensive to make.

Accordingly, it is desirable to produce cheaply orthohydrogen and/or parahydrogen using a cell and to be able to control the amount of either produced by the cell. It is also desirable to direct the produced orthohydrogen or parahydrogen to a coupled machine in order to provide a source of energy for the same.

SUMMARY OF THE INVENTION

It is therefore an object of the present invention to provide a cell having electrodes and containing water which pro-

2

duces a large amount of hydrogen and oxygen in a relatively small amount of time, and with a modest amount of input power, and without generating heat.

It is another object of the present invention for the cell to produce bubbles of hydrogen and oxygen which do not bunch around or on the electrodes.

It is also an object of the present invention for the cell to properly operate without a chemical catalyst. Thus, the cell can run merely on tap water. Moreover, the additional costs associated with the chemical catalyst can be avoided.

It is another object of the present invention for the cell to be self-pressurizing. Thus, no additional pump is needed.

It is another object of the present invention to provide a cell having electrodes made of the same material. This material can be stainless steel, for example. Thus, the construction of the cell can be simplified and corresponding costs reduced.

It is another object of the present invention to provide a cell which is capable of producing orthohydrogen, parahydrogen or a mixture thereof and can be controlled to produce any relative amount of orthohydrogen and parahydrogen desired by the user.

It is another object of the invention to couple the gaseous output of the cell to a device, such as an internal combustion engine, so that the device may be powered from the gas supplied thereto.

These and other objects, features, and characteristics of the present invention will be more apparent upon consideration of the following detailed description and appended claims with reference to the accompanying drawings, wherein like reference numerals designate corresponding parts in the various figures.

Accordingly, the present invention includes a container for holding water. At least one pair of closely-spaced electrodes are positioned within the container and submerged under the water. A first power supply provides a particular pulsed signal to the electrodes. A coil is also arranged in the container and submerged under the water. A second power supply provides a particular pulsed signal through a switch to the electrodes.

When only the electrodes receive a pulsed signal, then orthohydrogen can be produced. When both the electrodes and coil receive pulsed signals, then parahydrogen or a mixture of parahydrogen and orthohydrogen can be produced. The container is self pressurized and the water within the container requires no chemical catalyst to efficiently produce the orthohydrogen and/or parahydrogen.

BRIEF DESCRIPTION OF THE DRAWINGS

FIG. 1 is a side view of a cell for producing orthohydrogen including a pair of electrodes according to a first embodiment of the present invention;

FIG. 2 is a side view of a cell for producing orthohydrogen including two pairs of electrodes according to a second embodiment of the present invention;

FIG. 3 is a side view of a cell for producing orthohydrogen including a pair of cylindrical-shaped electrodes according to a third embodiment of the present invention;

FIG. 4a is a diagram illustrating a square wave pulsed signal which can be produced by the circuit of FIG. 5 and applied to the electrodes of FIGS. 1-3;

FIG. 4b is a diagram illustrating a saw tooth wave pulsed signal which can be produced by the circuit of FIG. 5 and applied to the electrodes of FIGS. 1-3;

FIG. 4c is a diagram illustrating a triangular wave pulsed signal which can be produced by the circuit of FIG. 5 and applied to the electrodes of FIGS. 1-3;

FIG. 5 is an electronic circuit diagram illustrating a power supply which is connected to the electrodes of FIGS. 1-3;

FIG. 6 is a side view of a cell for producing at least parahydrogen including a coil and a pair of electrodes according to a fourth embodiment of the present invention;

FIG. 7 is a side view of a cell for producing at least parahydrogen including a coil and two pairs of electrodes according to a fifth embodiment of the present invention;

FIG. 8 is a side view of a cell for producing at least parahydrogen including a coil and a pair of cylindrical-shaped electrodes according to a sixth embodiment of the present invention; and

FIG. 9 is an electronic circuit diagram illustrating a power supply which is connected to the coil and electrodes of FIGS. 6-8.

DETAILED DESCRIPTION OF PREFERRED EMBODIMENT

FIG. 1 shows a first embodiment of the present invention including a cell for producing hydrogen and oxygen. As will be discussed below in conjunction with FIGS. 6-8, the production of parahydrogen requires an additional coil not shown in FIG. 1. Thus, the hydrogen produced by the first embodiment of FIG. 1 is orthohydrogen.

The cell includes a closed container 111 which is closed at its bottom portion by threaded plastic base 113 and screw thread base 109. The container 111 can be made of, for example, plexiglass and have an exemplary height of 43 cm and an exemplary width of 9 cm. The container 111 holds tap water 110 therein.

The cell further includes a pressure gauge 103 to measure the pressure within the container 111. An outlet valve 102 is connected to the top of the container 111 to permit any gas within the container 111 to escape into an output tube 101.

The cell also includes a pop valve 106 connected to a base 113. The pop valve 106 provides a safety function by automatically releasing the pressure within the container 111 if the pressure exceeds a predetermined threshold. For example, the pop valve 106 may be set so that it will open if the pressure in the container exceeds 75 p.s.i. Since the container 111 is built to withstand a pressure of about 200 p.s.i., the cell is provided with a large safety margin.

A pair of electrodes 105a, 105b are arranged within the container 111. The electrodes 105a, 105b are submerged under the top level of the water 110 and define an interaction zone 112 therebetween. The electrodes 105a, 105b are preferably made of the same material, such as stainless steel.

In order to produce an optimal amount of hydrogen and oxygen, an equal spacing between the electrodes 105a, 105b must be maintained. Moreover, it is preferable to minimize the spacing between the electrodes 105a, 105b. However, the spacing between the electrodes 105a, 105b cannot be positioned excessively close because arcing between the electrodes 105a, 105b would occur. It has been determined that a spacing of 1 mm is optimal spacing for producing hydrogen and oxygen. Spacing up to 5 mm can work effectively, but spacing above 5 mm has not worked well, except with excessive power.

Hydrogen and oxygen gas outputted through output tube 101 can be transmitted by tube 101 to a device 120 using those gases, for example an internal combustion engine, such as shown in FIG. 1. Instead of an internal combustion

engine, device 120 may be any device using hydrogen and oxygen, including a reciprocating piston engine, a gas turbine engine, a stove, a heater, a furnace, a distillation unit, a water purification unit, a hydrogen/oxygen jet, or other device using the gases. With an adequately productive example of the present invention, any such device 120 using the output gases can be run continuously without the need for storing dangerous hydrogen and oxygen gases.

FIG. 2 shows a second embodiment of the present invention which includes more than one pair of electrodes 205a-d. The spacing between the electrodes is less than 5 mm as in the embodiment of FIG. 1. While FIG. 2 shows only one additional pair of electrodes, it is possible to include many more pairs (e.g., as many as 40 pairs of electrodes) within the cell. The rest of the cell illustrated in FIG. 2 remains the same as that illustrated in FIG. 1. The multiple electrodes are preferably flat plates closely spaced, parallel to each other.

FIG. 3 illustrates a cell having a cylindrically shaped electrodes 305a, 305b.

The outer electrode 305b surrounds the coaxially aligned inner electrode 305a. The equal spacing of the electrodes 305a, 305b is less than 5 mm and the interactive zone is coaxially arranged between the two electrodes 305a, 305b. While FIG. 3 illustrates the top portion of the container 111 being formed by a plastic cap 301, it will be appreciated to those skill in the art that the cap 301 may be used in the embodiments of FIGS. 1-2 and the embodiment of FIG. 3 can utilize the same container 111 illustrated in FIGS. 1-2. As suggested by FIG. 3, the electrodes can be almost any shape such as flat plates, rods, tubes or coaxial cylinders.

The electrodes 105a, 105b of FIG. 1 (or electrodes 205a-d of FIG. 2 or electrodes 305a, 305b of FIG. 3) are respectively connected to power supply terminals 108a, 108b so that they can receive a pulsed electrical signal from a power supply. The pulsed signal can be almost any waveform and have a variable current level, voltage level, frequency and mark-space ratio (i.e., a ratio of the duration of a single pulse to the interval between two successive pulses). For example, the power supply providing power to the electrodes can be a mains 110 volts to a 12 volt supply or a car battery.

FIG. 4a, FIG. 4b and FIG. 4c illustrate a square wave, a saw tooth wave and a triangular wave, respectively which can be applied to the electrodes 105a, 105b (or 205a-d or 305a, 305b) in accordance with the present invention. Each of the waveforms illustrated in FIGS. 4a-4c has a 1:1 mark-space ratio. As shown in FIG. 4b, the saw tooth wave will only reach a peak voltage at the end of the pulse duration. As shown in FIG. 4c, the triangular wave has a low peak voltage. It has been found that optimal results for producing hydrogen and oxygen in the present invention are obtained using a square wave.

After initiation of the pulsed signal from the power supply, the electrodes 105a, 105b continuously and almost instantaneously generate hydrogen and oxygen bubbles from the water 110 in the interaction zone 112. Moreover, the bubbles can be generated with only minimal heating of the water 110 or any other part of the cell. These bubbles rise through the water 110 and collect in the upper portion of the container 111.

The generated bubbles are not bunched around or on the electrodes 105a, 105b and thus readily float to the surface of the water 110. Therefore, there is no need to add a chemical catalyst to assist the conduction of the solution or reduce the bubble bunching around or on the electrodes 105a, 105b.

Thus, only tap water is needed for generation of the hydrogen and oxygen in the present invention.

The gases produced within the container are self-pressurizing (i.e., pressure builds in the container by the production of gas, without an air pump). Thus, no additional pump is needed to be coupled to the container **111** and the produced gases do not need to be transported into a pressurized container.

The power supply in the present invention is required to provide a pulsed signal having only 12 volts at 300 ma (3.6 watts). It has been found that an optimal amount of hydrogen and oxygen has been produced when the pulsed signal has a mark-space ratio of 10:1 and a frequency of 10–250 KHz. Using these parameters, the prototype cell of the present invention is capable of producing gas at the rate of 1 p.s.i. per minute. Accordingly, the cell of the present invention is capable of producing hydrogen and oxygen in a highly efficient manner, quickly and with low power requirements.

As noted above, the hydrogen produced by the embodiments of FIGS. 1–3 is orthohydrogen. As is well understood by those skilled in the art, orthohydrogen is highly combustible. Therefore, any orthohydrogen produced can be transported from the container **111** through valve **102** and outlet tube **101** to be used by a device such as an internal combustion engine.

The present invention, with sufficient electrodes, can generate hydrogen and oxygen fast enough to feed the gases directly into an internal combustion engine or turbine engine, and run the engine continuously without accumulation and storage of the gases. Hence, this provides for the first time a hydrogen/oxygen driven engine that is safe because it requires no storage of hydrogen or oxygen gas.

FIG. 5 illustrates an exemplary power supply for providing D.C. pulsed signals such as those illustrated in FIGS. 4a–4c to the electrodes illustrated in FIGS. 1–3. As will be readily understood by those skilled in the art, any other power supply which is capable of providing the pulsed signals discussed above can be substituted therefor.

The power supply illustrated in FIG. 5 includes the following parts and their exemplary components or values:

Astable circuit	NE555 or equivalent logic circuit
Resistor R2	10 K
Resistor R3	10 K
Resistor R4	10 K
Resistor R5	2.7 K
Resistor R6	2.7 K
Transistor TR1	2N3904
Transistor TR2	2N3904
Transistor TR3	2N3055 or any high speed, high current silicon switch
Diode D2	1N4007
Capacitors (not shown)	Vcc by-pass capacitors as required.

The a stable circuit is connected to the base of transistor TR1 through resistor R2. The collector of transistor TR1 is connected to voltage supply Vcc through resistor R5 and the base of transistor TR2 through resistor R3. The collector of transistor TR2 is connected to voltage supply Vcc through resistor R6 and the base of transistor TR3 through resistor R4. The collector of transistor TR3 is connected to one of the electrodes of the cell and diode D2. The emitters of transistors TR1, TR2, TR3 are connected to ground. Resistors R5 and R6 serve as collector loads for transistors TR1 and TR2, respectively. The cell serves as the collector load for transistor TR3. Resistors R2, R3 and R4 serve to respec-

tively ensure that transistors TR1, TR2 and TR3 are saturated. The diode D2 protects the rest of the circuit from any induced back emf within the cell.

The a stable circuit is used to generate a pulse train at a specific time and with a specific mark-space ratio. This pulse train is provided to the base of transistor TR1 through resistor R2. Transistor TR1 operates as an invert switch. Thus, when the a stable circuit produces an output pulse, the base voltage of the transistor TR1 goes high (i.e., close to Vcc or logic 1). Hence, the voltage level of the collector of transistor TR1 goes low (i.e., close to ground or logic 0).

Transistor TR2 also operates as an inverter. When the collector voltage of transistor TR1 goes low, the base voltage of transistor TR2 also goes low and transistor TR2 turns off. Hence, the collector voltage of transistor TR2 and the base voltage of Transistor TR3 go high. Therefore, the transistor TR3 turns on in accordance with the mark-space ratio set forth by the a stable circuit. When the transistor TR3 is on, one electrode of the cell is connected to Vcc and the other is connected to ground through transistor TR3. Thus, the transistor TR3 can be turned on (and off) and therefore the transistor TR3 effectively serves as a power switch for the electrodes of the cell.

FIGS. 6–8 illustrate additional embodiments of the cell which are similar to the embodiments of FIGS. 1–3, respectively. However, each of the embodiments of FIGS. 6–8 further includes a coil **104** arranged above the electrodes and power supply terminals **107** connected to the coil **104**. The dimensions of the coil **104** can be, for example, 5×7 cm and have, for example, 1500 turns. The coil **104** is submerged under the surface of the water **110**.

The embodiments of FIGS. 6–8 further include an optional switch **121** which can be switched on or off by the user. When the switch **121** is not closed, then the cell forms basically the same structure as FIGS. 1–3 and thus can be operated in the same manner described in FIGS. 1–3 to produce orthohydrogen and oxygen. When the switch **121** is closed, the additional coil **104** makes the cell capable of producing oxygen and either (1) parahydrogen or (2) a mixture of parahydrogen and orthohydrogen.

When the switch **121** is closed (or not included), the coil **104** is connected through terminals **106** and the switch **121** (or directly connected only through terminals **106**) to a power supply so that the coil **104** can receive a pulsed signal. As will be discussed below, this power supply can be formed by the circuit illustrated in FIG. 9.

When the coil **104** and the electrodes **105a**, **105b** receive pulses, it is possible to produce bubbles of parahydrogen or a mixture of parahydrogen and orthohydrogen. The bubbles are formed and float to the surface of the water **110** as discussed in FIGS. 1–3. When the coil is pulsed with a higher current, a greater amount of parahydrogen is produced. Moreover, by varying the voltage of the coil **104**, a greater/lesser percentage of orthohydrogen/parahydrogen can be produced. Thus, by controlling the voltage level, current level and frequency (discussed below) provided to the coil **104** (and the parameters such as voltage level, current level, frequency, mark-space ratio and waveform provided to the electrodes **105a**, **105b** as discussed above) the composition of the gas produced by the cell can be controlled. For example, it is possible to produce only oxygen and orthohydrogen by simply disconnecting the coil **104**. It is also possible to produce only oxygen and parahydrogen by providing the appropriate pulsed signals to the coil **104** and the electrodes **105a**, **105b**. All of the benefits and results discussed in connection with the embodiments of

FIGS. 1-3 are equally derived from the embodiments of FIGS. 6-8. For example, the cells of FIGS. 6-8 are self-pressurizing, require no-chemical catalyst, do not greatly heat the water 110 or cell, and produce a large amount of hydrogen and oxygen gases from a modest amount of input power, without bubbles on the electrodes.

A considerable amount of time must pass before the next pulse provides current to the coil 104. Hence, the frequency of the pulsed signal is much lower than that provided to the electrodes 105a, 105b. Accordingly, with the type of coil 104 having the dimensions described above, the frequency of pulsed signals can be as high as 30 Hz, but is preferably 17-22 Hz to obtain optimal results.

Parahydrogen is not as highly combustible as orthohydrogen and hence is a slower burning form of hydrogen. Thus, if parahydrogen is produced by the cell, the parahydrogen can be coupled to a suitable device such as a cooker or a furnace to provide a source of power or heat with a slower flame.

FIG. 9 illustrates an exemplary power supply for providing D.C. pulsed signals such as those illustrated in FIGS. 4a-4c to the electrodes illustrated in FIGS. 6-8. Additionally, the power supply can provide another pulsed signal to the coil. As will be readily understood by those skilled in the art, any other power supply which is capable of providing the pulsed signals discussed above to the electrodes of the cell and the coil can be substituted therefor. Alternatively, the pulsed signals provided to the electrodes and the coil can be provided by two separate power supplies.

The portion of the power supply (astable circuit, R2-R6, TR1-TR3, D2) providing a pulsed signal to the electrodes of the cell is identical to that illustrated in FIG. 5. The power supply illustrated in FIG. 9 further includes the following parts and their respective exemplary values:

Divide by N counter	4018 BPC or equivalent logic circuit
Monostable circuit	NE 554 or equivalent logic circuit
Resistor R1	10 K
Transistor TR4	2N3055 or any high speed high current silicon switch
Diode D1	1N4007.

The input of the divide by N counter (hereinafter "the divider") is connected to the collector of transistor TR1. The output of the divider is connected to the monostable circuit and the output of the monostable circuit is connected to the base of transistor TR4 through resistor R1. The collector of the transistor TR4 is connected to one end of the coil and a diode D1. The other end of the coil and the diode D1 is connected to the voltage supply Vcc. The resistor R1 ensures that TR4 is fully saturated. The diode D2 prevents any induced back emf generated within the coil from damaging the rest of the circuit. As illustrated in FIGS. 6-8, a switch 121 can also be incorporated into the circuit to allow the user to switch between (1) a cell which produces orthohydrogen and oxygen, and (2) a cell which produces at least parahydrogen and oxygen.

The high/low switching of the collector voltage of the transistor TR1 provides a pulsed signal to the divider. The divider divides this pulsed signal by N (where N is a positive integer) to produce an pulsed output signal. This output signal is used to trigger the monostable circuit. The monostable circuit restores the pulse length so that it has a suitable timing. The output signal from the monostable circuit is provided to the base of the transistor TR4 through

resistor R1 to switch the transistor TR4 on/off. When the transistor TR4 is switched on, the coil is placed between Vcc and ground. When the transistor TR4 is switched off, the coil is disconnected from the rest of the circuit. As discussed in conjunction with FIGS. 6-8, the frequency of pulse signal provided to the coil is switched at a rate preferably between 17-22 Hz; i.e., much lower than the frequency of the pulsed signal provided to the electrodes.

As indicated above, it is not required that the circuit (divider, monostable circuit, R1, TR4 and D1) providing the pulsed signal to the coil be connected to the circuit (astable circuit, R2-R6, TR1-TR3, D2) providing the pulsed signal to the electrodes. However, connecting the circuits in this manner will provide an easy way to initiate the pulsed signal to the coil.

A working prototype of the present invention has been successfully built and operated with the exemplary and optimal parameters indicated above to generate orthohydrogen, parahydrogen and oxygen from water. The output gas from the prototype has been connected by a tube to the manifold inlet of a small one cylinder gasoline engine, with the carburetor removed, and has thus successfully run such engine without any gasoline:

It will be obvious to those having skill in the art that many changes may be made to the details of the above-described embodiment of this invention without departing from the underlying principles thereof. The scope of the present invention should, therefore, be determined only by the following claims.

What is claimed is:

1. A method, comprising:

providing a container;
filling the container with a fluid including water until the container is at least partly filled;
submersing a pair of electrodes in the fluid;
positioning said electrodes so that they are spaced apart 5 mm or less; and
after submersing and positioning said electrodes, applying a pulsed electrical signal to one of said electrodes, the pulsed electrical signal having a frequency from 10 to 250 kHz, thereby producing hydrogen.

2. The method of claim 1 adapted to produce hydrogen in the absence of a chemical catalyst.

3. The method of claim 1 adapted to produce hydrogen in the absence of potassium hydroxide and sodium hydroxide.

4. The method of claim 1 in which the pulsed electrical signal has a mark-space ratio from 1:1 to 10:1.

5. The method of claim 1, further comprising:

providing a device having an input port connected to the output port of the container, the device selected from the group consisting of:
a. an internal combustion engine;
b. a reciprocating piston engine;
c. a gas turbine engine;
d. a stove;
e. a heater;
f. a furnace;
g. a distillation, unit;
h. a water purification unit; and
i. a hydrogen/oxygen flame jet; and
operating the device.

6. The method of claim 1, further comprising:

arranging a coil within the container; and
applying a second pulsed electrical signal to the coil.

7. The method of claim 1 in which the pulsed electrical signal is a variable voltage pulsed electrical signal.

9

8. The method of claim 1 in which the pulsed electrical signal is a square wave.
9. The method of claim 1 in which the pulsed electrical signal is a sawtooth wave.
10. The method of claim 1 in which the pulsed electrical signal is a triangular wave.
11. A method of producing hydrogen, comprising:
- providing a container;
 - filling the container with a fluid including water until the container is at least partly filled;
 - submersing a pair of electrodes in the fluid;
 - spacing said electrodes apart 5 mm or less to thereby form an interaction zone between said electrodes;
 - after submersing and spacing said electrodes, applying a pulsed electrical signal to one of said electrodes, thereby producing hydrogen and oxygen in the interaction zone;
 - arranging a coil within the container; and
 - applying a second pulsed electrical signal to the coil.

10

12. The method of claim 11 adapted to produce hydrogen in the absence of a chemical catalyst.
13. The method of claim 11 adapted to produce hydrogen in the absence of potassium hydroxide and sodium hydroxide.
14. The method of claim 11 in which the pulsed electrical signal has a mark-space ratio from 1:1 to 10:1.
15. The method of claim 11 in which the pulsed electrical signal has a frequency of from 10 to 250 kHz.
16. The method of claim 11 in which the pulsed electrical signal is a variable voltage pulsed electrical signal.
17. The method of claim 11 in which the pulsed electrical signal is a square wave.
18. The method of claim 11 in which the pulsed electrical signal is a sawtooth wave.
19. The method of claim 11 in which the pulsed electrical signal is a triangular wave.

* * * * *