

A WATER FUELED CAR

By **Carl Cella**

<http://www.hasslberger.com/tecno/hydrogen.html>

I am the madman behind the US heavy-metal band, "Rampage", but long before my musical success I was mechanically inclined, and the possibility of running a car on fuel extracted from water intrigued me no end.



After reading all the information I could find on the subject of hydrogen generators, I built my first actual unit in 1983, mounting it in the trunk of a 1979 Cadillac Coupe de Ville.

I constructed my system from the best of all the other systems I read about, and then went even further, using the strongest materials and cleanest layout possible within reason. All the titanium nuts and bolts were scored from an aircraft salvage supply: they're cheaper, used, and since they'll never wear out that's one way to save some big bucks. Certain head and exhaust system modifications have to be made to expect trouble-free extended use. For one, the combustion of hydrogen results in the re-bonding of the previously-separated hydrogen and oxygen molecules, making the engine's exhaust water vapor steam, and nothing else - meaning absolutely no pollution at all!

Most auto makers use cast-iron exhaust manifolds and steel valves. The combined effects of heat and moisture (moisture not being present in the combustion of petroleum-based fuels) cause extremely rapid corrosion of the system. Part of the fix is to install stainless-steel valves and an exhaust system constructed entirely out of stainless steel. Racing shops sell stainless-steel valves and stainless-steel 'turbo' mufflers that all work fine. Since hydrogen does not contain lead as some gasoline does, if you're not using a late-model, no-lead engine, the heads will have to be reworked to include valve seats not needing the lubrication lead provides.

As for building this device to sell as a completed system, that's a dead issue. In 1983, I contacted the Department of Energy to show them that my car actually worked. I was confronted by two very belligerent 'agents of tyrannical oppression' who told me that if I tried to sell pre-built units, I'd have a lot of "problems". I asked why, demanding an explanation, and was told very bluntly, and not in a very nice tone: "Do you have any idea what a device like this, available to the public, would do to the economy?"

This technology is so simple that anyone with over half a brain - and knowledgeable in auto mechanics - can build one of these units. I've included comprehensive, no-bullshit, drafted design layouts, parts lists, maintenance tips, and a whole lot of engine modification concepts to make construction, part fabrication and implementation as easy as reasonably possible.

The unit I built works as great as I claim it to, but I offer only the printed information on how to build your own, and I take no personal responsibility for damage of any kind caused to your vehicle or self.

I have only applied my unit to a carburetted engine; I've never attempted an application to a fuel-injected engine, nor do I make any such claim that an application of that type would be easily performed, if possible at all.

Every cubic foot of water contains about 1,376 cubic feet of hydrogen gas and 680 cubic feet of oxygen. Because there is no pollution produced, all smog devices may be completely removed, legally, and your car exempted from smog checks, as are propane-powered vehicles.

The only maintenance I have encountered is, periodically, to wire-brush mineral deposits off the reaction chamber electrodes and, at longer intervals, to clean out the chamber itself - neither of which is complicated or very time consuming. I've incorporated so many backup electrodes so this job won't be required roadside - as it was for me when I first used only one, not knowing about any deposits entirely covering the electrodes and thus halting the electrical reaction process. When the car dies out, you just flip another switch until you're somewhere able to brush the reactor's electrodes clean in reasonable comfort - and not northbound on Highway 5, halfway between Los Angeles and San Francisco, where my first breakdown was.

Where the steel gasoline tank used to be, a plastic water tank is fitted, along with an electric float sensor that should be attached to the vehicle's existing fuel gauge. If you were to start your engine with no modifications other than the carburettor to accept hydrogen fuel, it will run fine but the exhaust system will corrode in almost no time, and if you leave the engine turned off for an extended period, your stock valves and guides will rust up and seize!

Stainless-steel valves don't cost much and are as trouble-free as the stainless-steel exhaust system, so don't be a fool and try to go cheap because you'll only cause yourself added expense and headaches, and you'll be cursing me for your own stupidity. For the cast-iron combustion chambers and valve ports, there is a high-temperature ceramic coating called "Heanium" [manufactured by Heany Industries

Inc. www.Heany.com ~O.F.] that can be pre-formed to guard against the same corrosion that affects the valves, guides, exhaust system and also the intake manifold, as moisture down there will also cause corrosion.

Petroleum-based fuels have their own detergent action that protects against corrosion, much like soaking parts in oil prevents corrosion. When using hydrogen as an internal combustion engine fuel, extra precautions must be taken to make extended operation a reality, and not some drive-a-few-thousand-miles-between-fried-engines bullshit.

Don't use sea water! It contains approximately three-fourths of a pound of salt in every gallon. Salt is a material that will coat the electrodes very quickly, just making one big mess. The reason for electrode deposit buildup is that tap water is never 100 per cent pure: it contains mineral contaminants that are drawn to the traction-chamber electrode during the electrically-activated molecular separation process, that results in the hydrogen contained in water being released from the oxygen molecules they are bonded to, making a fuel that can power an internal combustion engine.

I offer no design for an exhaust steam condenser, but I do make the suggestion that one applicable to an automobile can be built to increase the cost-free mileage even further between fill-ups. A concept would include some form of exhaust-fed radiator that could incorporate air ducts, leading from scoops, to direct highway speed airflow across it.

I offer the idea, but not the design, because many aspects must be considered, such as: the least amount of back pressure, unit pressure, unit placement with regard to configuration by the limit or abundance of that space - though this one would be constructed for a stationary, engine-powered electrical generator, where space limitation is of no concern.

Remember, the cylinder walls are cast iron and prone to rust, but they can be kept clean by piston action (as long as it's not left sitting for long periods between use).

An automobile engine could feasibly be constructed with non-corrosive stainless-steel heads and cylinders straight from the factory - a solid reason to justify spending twenty-five grand or more for a car, because the fuel to run it would be free.

There has been much criticism over hydrogen as an auto fuel, most of it coming straight from those who have the most to lose if hydrogen ever achieves widespread

use as an automotive fuel.

There are some factory-built high-performance cars on the market that already come with stainless-steel valves, but they are few and far between, and you still have to change the exhaust systems.

For the carburettor to accept vapour-state fuel, it must be converted using the same parts that are used in propane/butane engine fuel systems, such as carburettor kits by "IMPCO", or similar, that do the same thing, i.e. enable your engine to be powered by a vapour-state fuel.

Because no pollution is produced, the engine may be rebuilt 'legally' with higher performance parts, like a camshaft that, in gasoline, would have increased exhaust pollutant emissions, thus making it 'illegal' for highway use. Of course, it's only a 'crime' if you get 'caught', but those pay-again-every-time-your-vehicle-fails smog checks are a pain in the ass, not to mention the wallet.

A similar type of mechanism that opens and closes the retractable headlights could be implemented in a dashboard switch-activated system that could open a trunk lid-mounted scoop that captures rain, with a flexible hose line that directs it into the main tank, either while the vehicle is in motion or parked. Just watch the fuel gauge, and close the scoop when you see "Full"!

While it may be a long time before we are able to purchase an entirely corrosion-resistant, exotic alloy engine, I am offering the complete design for a hydrogen generator that will power a car - but any engine modifications I outline are only given as basic concepts. It's up to you to implement what is applicable to your particular engine. Use some initiative. Don't rely on whether I wrote it or not. If you discover a part or process that I haven't mentioned, that will in any way protect your engine further from the effects of corrosion, use it! I've written this to help people wake up from the big lie of having to depend on oil companies just to drive a car.

Building as many units as I can for personal use only, and writing this booklet, are about the only things I can 'legally' do to try to help the world wake up. A hydrogen generator produces an energy potential in excess of 100 per cent efficiency!!! You read it right: free energy!

A car's battery starts the engine, but once it's running, the alternator takes over to charge the battery and power the ignition system. With an on-board hydrogen generator, that alternator also powers the hydrogen extraction process, producing

the energy needed to fuel the engine that runs the alternator. No external power source is needed; so long as there is water available, the entire system is self-sufficient in operation. An extra trunk-mounted battery would provide more current - if ever needed - to run everything at once without overloading the electrical system.

System Operation

The dash-mounted switches for turning on the reactor are also wired to activate the chamber feed-water pump at the same time. When the car dies out, that signals to you that an electrode has been totally crusted over with deposits from the impure fuel water. This means the electrically-activated molecular separation process (electrolysis) has halted. These switches should also have indicator lights to let you know which one is on, and flip-up caps to guard against accidental activation.

When the need arises to go to back-up, turn off the switch for the 'dead' electrode, as well as close its electrical shut-off-valve. The purpose of these gas valves is to keep pressurized oxygen from escaping up through the 'off' electrode fittings into the hydrogen lines, possibly resulting in your car becoming a "Highway Hindenburg"!

Hydrogen is separated from its molecular bond with oxygen by exposing the fluid of water to direct-current voltage. Hydrogen is attracted to a negative charge, while oxygen is attracted to a positive charge. This process generates heat in the chamber, so trunk placement is best with an Aluminum or plywood wall built between the reactor and the rest of the available trunk space. Small cars are light on gasoline, thus cheaper to operate, but when all of a sudden the fuel becomes free, the size and weight of the car is of no concern, except for Porsches and similar sportscars, street rods etc.

Water is pumped through the reaction chamber, which itself is positively charged, drawing the oxygen molecules out through the water return line to be vented off through the water tank's cap. The hydrogen-attracting electrode extending into the welded-in pipes (and insulated under the T-fitting) is negatively charged. There is a dash-mounted pressure-gauge that is connected before the regulator and mixer. To begin hydrogen generation, flip one of the dash-mounted switches and wait for the gauge to show fuel-line pressure; then start the engine when pressure is shown by the gauge to exist. In mounting the unit, remember that the chamber itself is positive, and most cars use a negative chassis ground, so insulated mounts must be fabricated between the positive chamber and the negative trunk-floor.

As a final note, this unit is not a concept or a theory! It is tried and proven! I designed this system at age 18 in 1983, and built more than one, using Rampage profits for research and development.

I can't sell actual working units, but nothing but death itself can stop me from distributing this information in the hope that people will take the initiative to wake up from the big lie of oil-dependency for auto fuel, and flood the street with hydrogen-powered cars.

If enough people find out how simple it is, public pressure may someday soon be put on the government, resulting in the long overdue media exposure they're all so afraid of. Eyewitness News (Channel 7) in Los Angeles didn't want to let the word out that an actual working vehicle had been built by an 18-year-old metalhead! We're supposed to be stupid in the public's eye, from their point of view!

Hydrogen and oxygen gases do not pollute; they help clean out carbon deposits from the engine for better mileage and less engine wear. You'll notice the improved engine performance immediately.

Source: Carl Cella, PO Box 8101 (4176-X), San Luis Obispo, CA 93409-0001, USA. Originally published in Iron Feather Journal No. 13, PO Box 1905, Boulder, CO 80306, USA; in Psychedelic Illuminations VIII, Fall/Winter 1995/96, PO Box 3186, Fullerton, CA 92634, USA; and in Nexus magazine, www.nexusmagazine.com

DRAWINGS

The next two pages display line drawings with general construction plans for Carl Cella's water car.

Do-It-Yourself Special Feature: MODIFY YOUR CAR TO "BURN" WATER! - - Technical Diagrams (reproduced exactly as we received them)

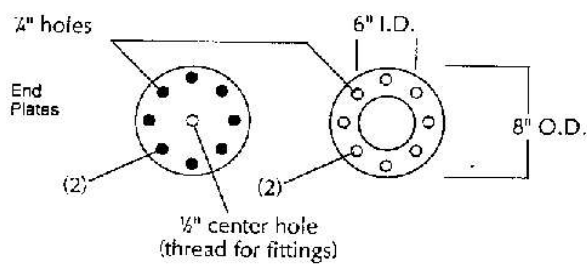
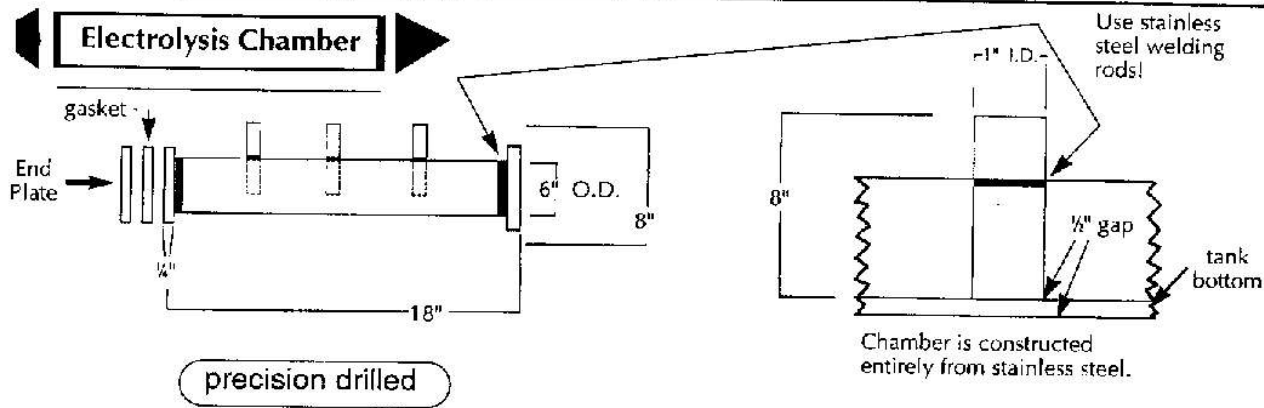

Get the materials listed below!

- (1) 18" x 6" O.D. x 1/4" stainless steel pipe
- (3) 8" x 1" I.D. x 1/8" stainless steel pipes
- (2) 8" O.D. x 6" I.D. x 1/4" end flanges
- (2) 8" x 1/4" end plates
- (16) 1" x 1/4" aircraft salvaged titanium bolts
- (16) 1/4" aircraft salvaged titanium self-locking nuts

For the vapor fuel conversion parts:
 (fuel mixer, and low pressure regulator)
IMPCO CARBURETION
 16916 Gridley Plaza
 Cerritos, CA 90701 USA

HERE'S How:

Hydrogen Electrode Fabrication (Exploded View)

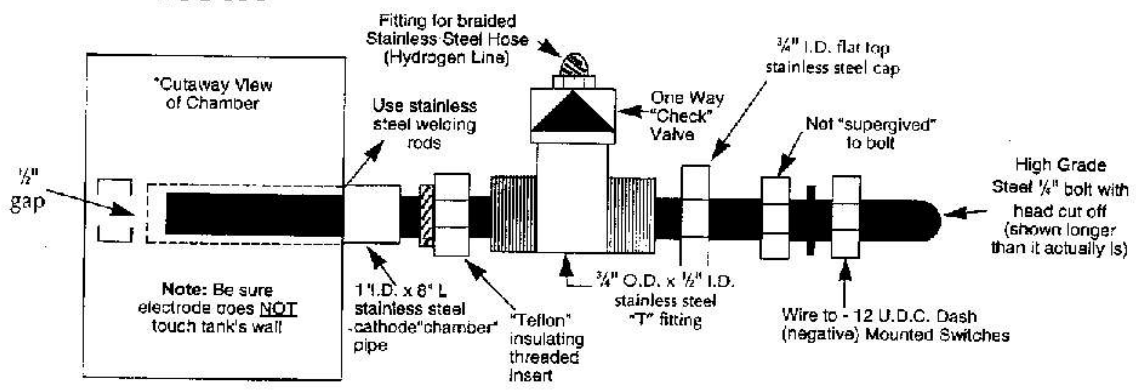

Hydrogen burns slightly hotter than gasoline

KEY:
 O.D. = Outside Diameter
 I.D. = Inside Diameter
 V.D.C. = Voltage Direct Current

HYDROGEN GENERATOR INSTALLATION

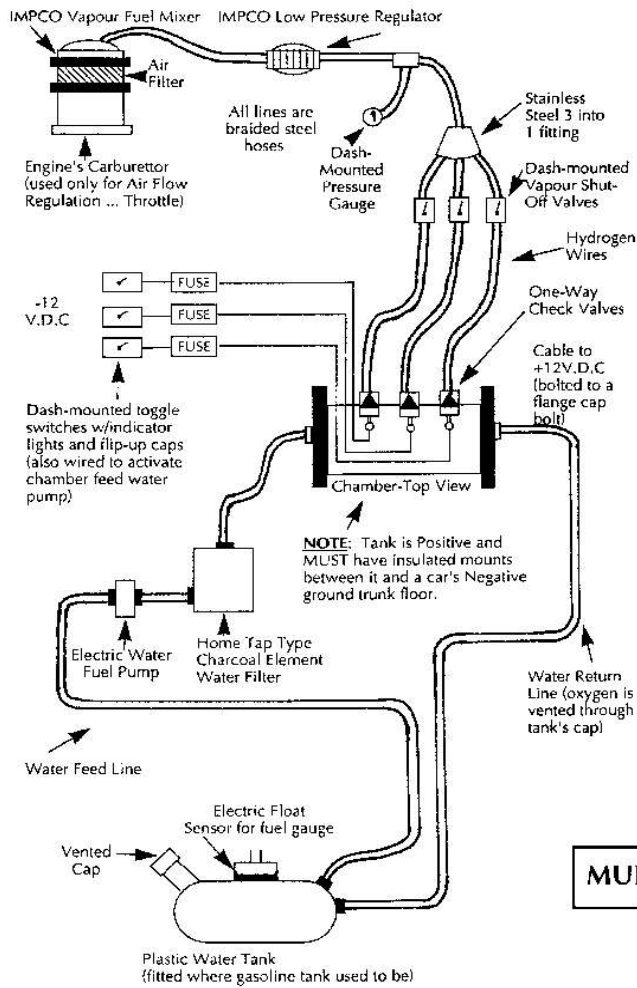

CHAMBER MOUNTING IN CAR'S TRUNK

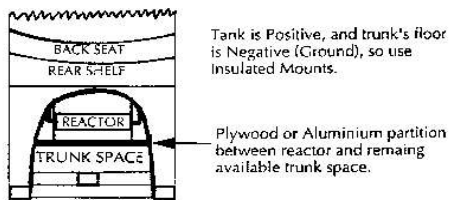

- ### GENERAL PARTS:
- Stainless Steel Valves
 - Bronze Valve Guides
 - Stainless Steel Piston Rings
 - Stainless Steel Headers
 - Stainless Steel Mufflers
 - Stainless Steel Exhaust Tubing

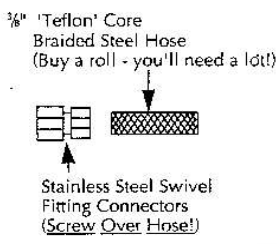

- * Stainless Steel Dual Exhaust System (Headers)
 - * Electric Muffler Drain/Water Recovery Pump fed back into Main Tank ("T"-fitting between both stainless steel turbo mufflers using heat-proof braided steel hose)
- NOTE:** The combustion of hydrogen results in the reformation of water. The engine's exhaust is water vapour steam. Some of this steam condenses into water, collecting inside the mufflers. This system recovers the water content of these mufflers.

MUFFLER WATER RECOVERY SYSTEM CONCEPT

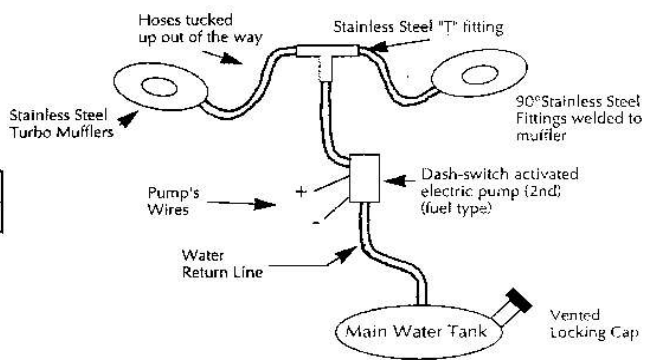

EXTRA: REAL OPERATING UNIT

[These photographs and reports have been emailed to the author, Carl Cella, on January 15, 2003]

Here is a real operating unit, still need a percentage of fuel to keep the carbon around the rings. That's why you have to run a car in for a few thousand miles. Without the carbon the engine will not last.

The fuel this unit generates is not hydrogen oxygen; it's nitrogen hydroxide - nitrogen hydrogen and oxygen combined. The motor is a 253 v8 with a lawn mower carby 1 inch bore.



The system is fairly basic: 316 stainless 100mm pipe anode, 80mm pipe cathode inside the other one roughly equal surface area anode and cathode perspex end caps, 1 12-volt relay, 1 bleed valve to allow atmospheric air in.

This is how the nitrogen is replaced. The atmosphere is over 70% nitrogen; the real work is done by the vacuum generated by the engine plus the 12 volt current. The only catalyst is a grain or two of rock salt. When you turn the thing off it generates 13 to 14 volts for a while.

The car in the picture did 3000 mile on \$20 fuel [petrol] roughly [2 gallons] and two liters of water.

