

## A&I Power Group

# **A&I Generators - Technical Overview**

Alexis Herrera, Iyad Baghdane  
A&I Power Group  
Miami, FL

# **A&I Generators - Technical Specifications**

Alexis Herrera, Iyad Baghdane  
A&I Power Group  
Miami, FL

## **INTRODUCTION**

The global energy market is estimated at USD 95 trillion between 2019 and 2050. The Paris Agreement is one key driver to find replacements to fossil fuels. A number of renewable sources, such as wind, solar, and tidal, are providing an increasing percentage of energy supply, but they require far larger resources in land and related infrastructure.

From A&I's long experience in power generation, the team has developed and patented (Granted US Patent 10,770,937) an electrical power generation technology that addresses the limitations of both fossil fuel and existing alternative energy generation technologies.

The company has developed an 8wh prototype and is seeking commercialization partnerships and licensing to develop larger prototypes for different generation verticals.

The purpose of this document is to describe the technical architecture of the existing prototype and provide information on the testing process which proves the validity of the patented technology.

## **IDEA ORIGATION AND BENEFITS**

Since the early 2000s, A&I has provides advice and services relating to more than 200 generators placed in service at several utility companies and industrial plants around the world.

By studying the present theoretical principle used in the production of electricity it was found that the existing processes to make most of the electricity used today are at best 60% efficient. In addition, these processes use non-renewable natural resources and contribute to the present major world environmental concerns.

The research findings show that in order to produce electricity there is no need to consume a constant input of fuel or cause any environmental concerns.

The novelty postulated was to produce electricity without the use of any mechanical, wind, solar, hydraulic or nuclear energy, and at the same time without affecting the environment.

After analyzing the theoretical principal in detail on how today the world produce electricity, it was obvious that to make electricity, mechanical energy was not needed.

The A&I invention relates to a highly efficient method of generating electricity based on electromagnetic theory. The technology is a new application based on Faraday and Maxwell's equations. While traditional systems suffer significant loss in energy due to the inefficient systems relying on mechanical components and combustion, A&I technology solves this problem by maximizing efficiency while perfectly obeying the laws of physics.

When comparing the new technology to traditional electrical energy generation, it is observed that a higher yield from the new technology is achieved. That increase in efficiency is directly related to removing all inefficiencies and physical limitations in the traditional system (i.e. mechanical and combustion dependencies) and the energy loss associated with those older

techniques. As an additional benefit, our patented technology presents a green, environmentally friendly approach to electrical energy generation which is easily integrated into traditional systems to obtain the target efficiency with minimal maintenance for continued optimal operation.

After several trials, a prototype was constructed and proved that power could be generated without the need of any mechanical energy or alternative energy. In other words, the above-proposed idea was practically confirmed. As a result, A&I Power Group has been granted US Patent 10,770,937.

## **MARKET NEEDS**

The basic design of a generator, while influenced primarily by material and electromagnetic properties, is also impacted by market requirements. Hence, customer discussions as well as recent market trends are used in the development of a final generator design. Some of these include: cable ratings, industry standards, generator ratings, etc.

The scalability of the solution means that the patented technology can be licensed to businesses wishing to provide electrical power solutions to many industries, including but not limited to:

- IoT devices
- Drones
- Electric cars
- Larger vehicles including trucks, trains, planes and ships
- Backup generators in homes, offices, hospitals and other infrastructure
- Large, portable generators for emergency use, such as after natural disasters
- Replacement generators in existing power plants
- New power plants

## **A&I GENERATOR**

A&I generators can be produced in two basic configurations:

- With Core (WC)
- Without Core (WOC), see figure 6 & 10.

Note that, in what follows, this document refers to “rotor” even though there is no moving device. This decision is for convenience, as the component serves the same purpose as a traditional rotor.

In WC design, the rotor coil is wound around the core. The rotor and stator coils are constructed in such a way that the electromagnetic field vector created in the rotor coil is parallel to the normal vector area of the stator coil. This allows for the maximization of the energy transfer from the electromagnetic field created in the rotor to the free electrons within the stator copper coil. The advantage of this design is the operation at a high magnetic field values.

In WOC design, there is no core. The rotor coil is wound around the stator coil. This allows for the maximization of the energy transfer from the electromagnetic field created in the rotor

to the free electrons within the stator copper coil. The advantage of this design is the simplicity in construction, and lower material cost.

## **STANDARDS**

All new designs will meet the requirements of the applicable ANSI and IEC standards

### **RELIABILITY**

Particular attention has been paid to known problem areas based on in service generator global experience.

The A&I generator is designed such that provides a high level of reliability and availability through elimination of all mechanical moving parts, and simplicity of operation. In addition, the reliability of the product will improve through further design simplification and standardization, discussed below.

### **PRODUCT STANDARDIZATION**

Standardization of the product line has significant benefits both to the user and to the manufacturer.

From the user's viewpoint, the standardization of the product line translates into a simpler machine with no moving parts.

The benefits to the manufacturer are that, with no moving parts to track and check, fewer different assemblies to build and fewer drawings to keep up to date, the job of building a high-quality machine becomes simpler.

### **DESIGN AND CONSTRUCTION FEATURES**

The A&I team worked with numerous representative customers to better understand user needs. In this way, the technical requirements of the designs were

influenced by the needs of all the functions involved in the manufacture, marketing and maintenance of the generator. Features were incorporated into the design specifically to aid producibility. Visits to and discussions with potential vendors influenced the design of components both for improved performance and to suit vendors' capabilities. Careful cost comparisons were made of alternative design approaches to ensure that the final configurations are cost effective.

### **ELECTROMAGNETIC DESIGN**

To achieve the reliability objectives of the project, no new electromagnetic design limits have been used. The designs are based on proven technology used in generators already in service. Where appropriate, the technology used in larger units has been drawn upon to improve the designs of these machines. In reaching the final configuration, a large range of design alternates is considered, and the final choice of design reflects the optimization of the types of consideration described herein.

### **STATOR DESIGN**

In the WC configuration, the stator frame is mounted on a single base fabrication. The inner frame is a very simple structure designed to support the stator core and winding while providing some guidance to the airflow in the machine. The stator core is mounted rigidly in the inner frame.

The outer frame is a simple fabricated enclosure, which supports the air inlets. The outer frame further acts as an air guide

to complete the ventilation paths and as a soundproof enclosure to keep noise levels low.

The entire generator is mounted on a single fabricated base, which supports the pedestals, the inner and outer frames.

The insulating materials are those used since the early 1930s thus maintaining the proven reliability record. The materials are all designed and tested to provide reliable performance at Class F temperatures for the life of the machine.

In the WOC configuration, there is no core material. Hence, the stator winding is wound around nonconductive electromagnetic rods.

The insulating materials are those used since the early 1930s thus maintaining the proven reliability record. The materials are all designed and tested to provide reliable performance at Class F temperatures for the life of the machine.

## ROTOR DESIGN

In the WC configuration, the rotor core (Figure 8) is a simple single-piece forging.

The rotor winding is wound around the rotor core. The insulating materials are those used since the early 1930s thus

maintaining the proven reliability record. The materials are all designed and tested to provide reliable performance at Class F temperatures for the life of the machine.

In the WOC configuration, there is no core material. Hence, the rotor winding is wound around the stator winding in such a way that the electromagnetic field vector created in the rotor coil is parallel to the normal vector area of the stator coil. This allows for the maximization of the energy transfer from the electromagnetic field created in the rotor to the free electrons within the stator copper coil. The advantage of this design is the operation at a high magnetic field values.

## TESTING

Extensive prototype testing of each of the new designs, at A&I testing laboratory, has proven that the designs meet all the expected performance requirements throughout the load range. Some of the key test objectives are listed in Figure 12.

### Figure 12 – Testing Objectives

Loss measurements confirmed the prediction of generator efficiency at the generator rated output, in A&I testing laboratory under load conditions.

Electrical Testing
Excitation Requirements
Current Input/Output
Resistance Input/Output
Inductance Input/Output
Insulation Resistance
Resonance Capacitance
Power Input/Output
Temperatures

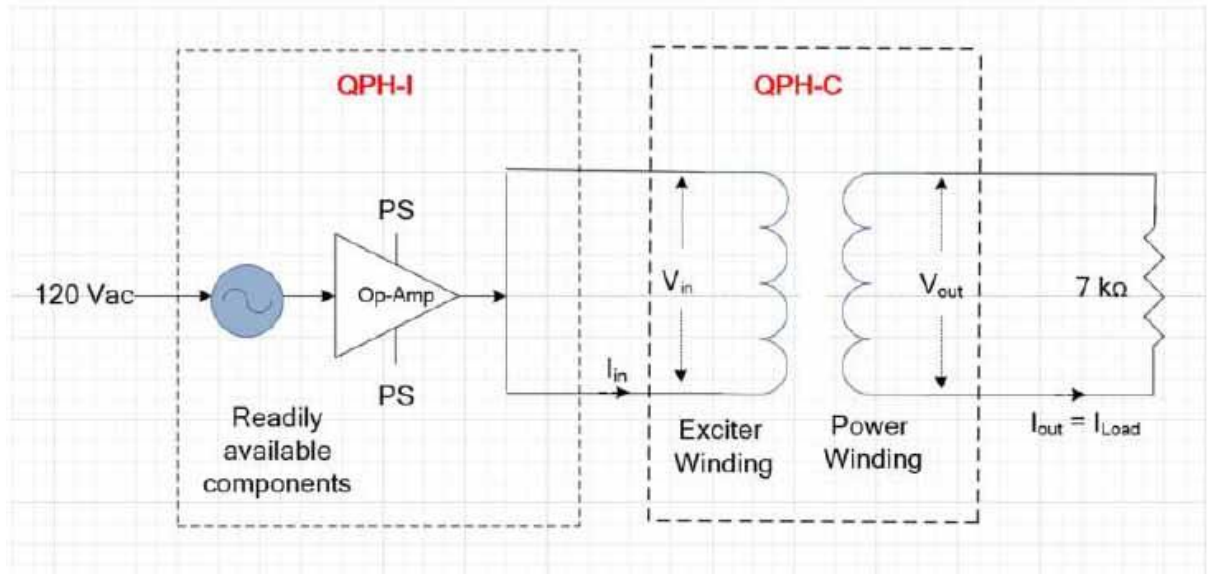

Figure 1- Performance Test Setup

$V_{in}$	17.03 V		$V_{out}$	236 V
$I_{in}$	88.36 ma		$I_{out}$	35.78 ma
Freq <sub>in</sub>	161 kHz		Freq <sub>out</sub>	161 kHz
$P_{in}$	1.50 watts		$P_{out}$	8.44 watts

**at 7kΩ load**

Energy harness ratio: $P_{out} / P_{in} =$	5.63
--	------

$V_{in}$	17.03 V		$V_{out}$	750 V
$I_{in}$	88.36 ma		$I_{out}$	0 ma
Freq <sub>in</sub>	161 kHz		Freq <sub>out</sub>	161 kHz
$P_{in}$	1.50 watts		$P_{out}$	0

**No Load Condition**

Figure 2- Performance Test Results

Blue – Input Current  
Yellow – Input Voltage & Frequency



Blue – Output Current  
Green – Output Voltage & Frequency

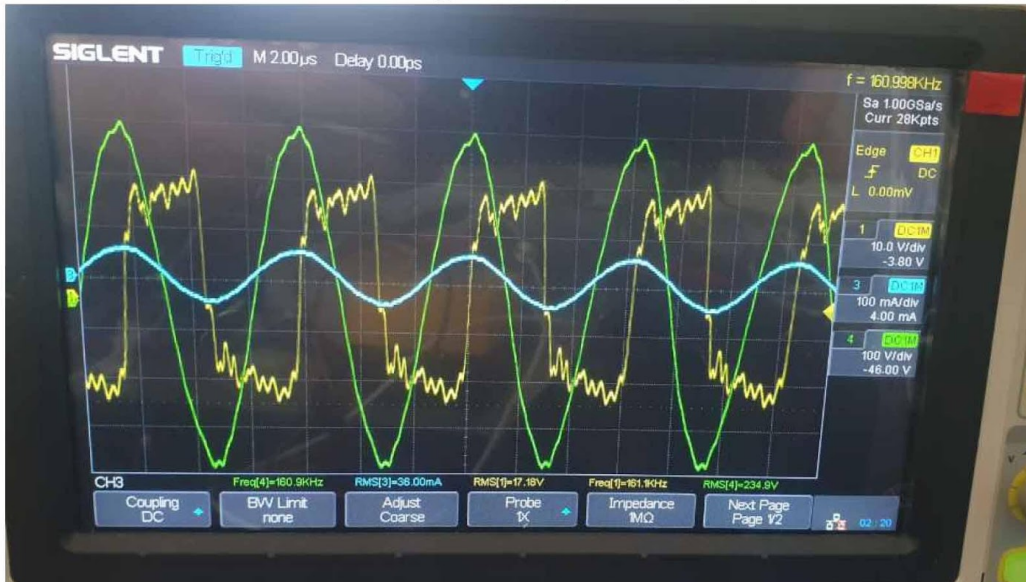
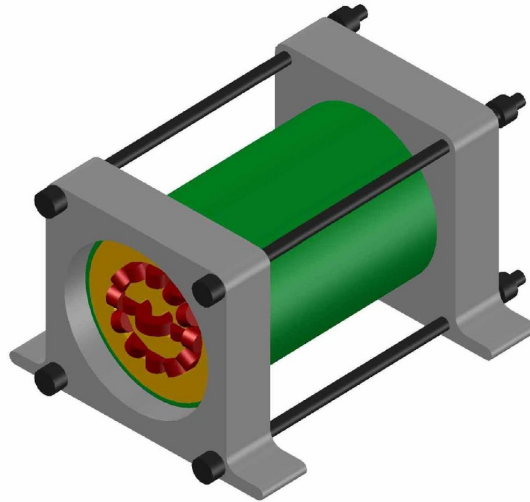
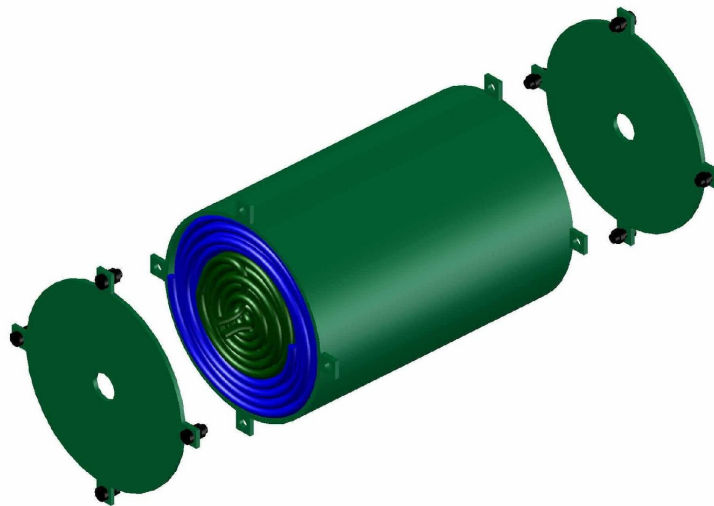

Figure 3- Performance Test Data



A	11.02.19	MRA		AH	ISSUED FOR REVIEW	A&I POWER GROUP		DRAWING TITLE:				
REV.	DATE	DR'N	CH'D	AP'D	DESCRIPTION			GENERATOR PROTOTYPE 3	01	OF	07	0
SCALE: NTS									SHT	OF	SHT	REV

**Figure 4- Generator Packing (WC Configuration)**



A	11.17.19	MRA		AH	ISSUED FOR REVIEW	A&I POWER GROUP		DRAWING TITLE:				
REV.	DATE	DR'N	CH'D	AP'D	DESCRIPTION			GENERATOR PROTOTYPE 9	01	OF	03	0
SCALE: NTS									SHT	OF	SHT	REV

**Figure 9- Generator Packing (WOC Configuration)**