

AESOP: ENERGY REVOLUTION

AESOP's COOL solution: Incredibly efficient air-conditioners without refrigerants!

The best way to reduce greenhouse gases? Build a better air conditioner! Now in development - A/C using 1/3 the power - No Refrigerants! The science is proven.

THE MARKET: A/C Market worth 24.28 Billion USD by 2020. The number of cooling devices is expected to quadruple to 14 billion worldwide by 2050.

AESOP is a startup operating on a shoestring, despite vicious rants by a cowardly anonymous troll and sophisticated hacks by vested interests. Every effort has been made to discredit our work and libel me personally. But we have survived with superior technology.

Ken Rauen, AESOP's Chief scientist and CTO has developed new technology with a Coefficient of Performance - COP - exceeding 11. A figure beyond the wildest expectations of air conditioning engineers and manufacturers anywhere on the planet. This proprietary work will be patented, produced in the USA and licensed world-wide.

Air Conditioning: Currently a Life-Saver — and a Danger

***Time magazine* "Extreme heat is now a world-wide phenomenon. It poses a vexing paradox for scientists and policymakers: today's air conditioning keeps people cool and saves lives but is also one of the biggest contributors to global warming. Only 8% of the 2.8 billion people living in the world's hottest regions own an air conditioner, compared with more in the U.S. and Japan. Air-conditioning isn't just a luxury. Without adequate cooling, heat exhaustion can disrupt the body's functioning and lead to death."**

See CHEAP GREEN A/C on this website. Help complete a prototype and speed this urgent work into production.

UN chief: World has less than 2 years to avoid 'runaway climate change'

WAGING WORLD WAR CO2

IT'S WAR! Abrupt Climate Change - wildfires, floods, super-storms, rising sea level, droughts and extreme heat are now raging all across the planet.

Atmospheric concentrations of Carbon Dioxide - CO2 - have passed 400 parts per million - a clear red line opening a danger zone. Climate chaos threatens the survival of every man, woman & child.

We must take action to drive CO2 back toward 350 parts per million fast.
Humanity needs this new technology now.

An Infinite Energy magazine article by Ken Rauhen describes the science behind both the Heat Pump Air Conditioner and AESOP's engines. Available upon request.

OUTLINE OF AESOP's STRATEGIC PLAN

Replace fossil fuels faster with breakthrough science. Existing wind and solar pv farm technology is intermittent and too slow.

COMING SOON! Engines converted to run on water, fresh or salt. Think about it - sharply reduced need for gas, diesel or jet fuel! Cars, trucks, boats, ships, aircraft and power plants of every variety running on water. Proven technology. See MOVING BEYOND OIL on this website.

NEEDED NOW! AESOP's fuel-free 24/7 solar powered engines. Science proven! Prototype and commercial production required.

Financial assistance sought. Call me, Mark Goldes, for a great green deal. 707 861-9070 mark@aesopenenergy.com

[AESOP Energy: Ambient Solar Heat – A key to faster replacement of fossil fuel!](#)

24/7 Fuel-Free, Solar Powered Technologies. Alternatives to intermittent solar panels and wind.

Ambient Heat – Sleeping Giant Solar Energy Source.

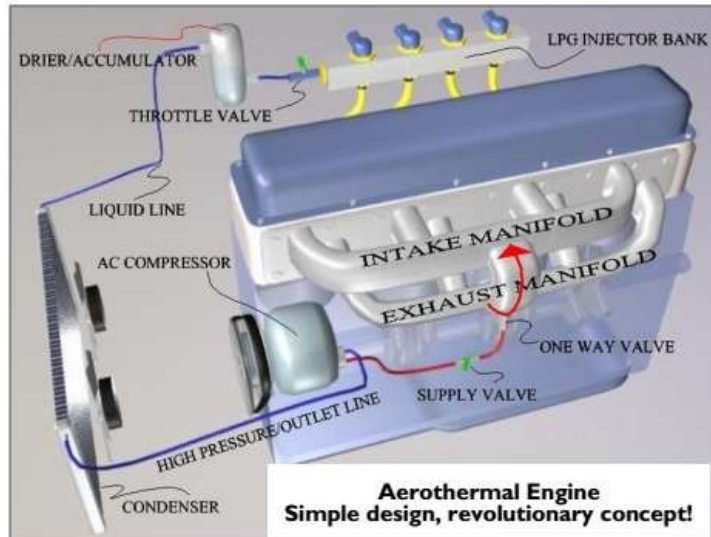

Ford engine converted to run on ambient energy by Chris Hunter

Aerothermal ambient heat will replace fuel in AESOP's piston engines and turbines under development. This new science opens a 24/7 path to solar powered homes and ultra efficient heat-pumps for heating and cooling. **Tapping ambient heat is one of the missing keys to rapid replacement of fossil fuels!**

New technology will provide electric vehicles with unlimited range and allow them to become power plants when suitably parked, selling electricity or powering buildings.

See NO FUEL PISTON ENGINES and FUEL FREE TURBINES on this site.

"Recent challenges to The Second Law of Thermodynamics from a number of research groups focus on those most amenable to laboratory test. The most significant result appears to be the recycle ability of environmental heat into usable work. The thermal energy content of the atmosphere, ocean, and upper crust is estimated to be more than 10,000 times that of the world's fossil fuel reserves, making it a potentially inexhaustible reservoir of green energy." *Prof. Daniel Sheehan PhD University of San Diego*

SAVINGS: AESOP's technology could save the average American family of four up to \$8,000 per year on energy. (Gas for car[s]; home heating & cooling; appliances).

AESOP Energy needs your help NOW to keep the facility open and the work on track. Trolls and vested interests attack! They deter financial support! Conventional thought dismisses the new science. Convertible Loans are urgently needed. Exceptional terms! The effects of your assistance will multiply exponentially! Contact: Mark Goldes mark@aesopenergy.com 707 861-9070

7 MINUTE VIDEO: http://youtu.be/YqWzF8FG_AQ



TROLL ALERT: AESOP is slandered by **Trolls**. Vicious rants by a **cowardly**, 'anonymous individual' posing as a **(fake)** Physics Review Board (cobbling together a few distorted facts mixed with blatant lies) seeks to deflect support for AESOP's new science. **4 U.S. Government Ultraconductor Contracts Completed – LORD Corp. now using this AESOP research to PROTECT AIRCRAFT AGAINST LIGHTNING STRIKES!**



The VISION VTOL aircraft, invented by Mike Waters, AESOP Energy CEO

Video: <https://www.youtube.com/watch?v=YSJKQSxUeVo>

AESOP Energy

OPPORTUNITY

The current renewable energy industry's prime products are intermittent solar panels and wind energy. They cannot compete with base load power plants without the addition of costly electric storage systems. They often require expensive and time consuming extensions of the grid. AESOP Energy systems can supplement or replace them.

THE MARKET

The market for clean energy last year was \$333.5 billion (Bloomberg). The market is expected to grow as most nations increasingly favor renewables.

AESOP Energy is a start-up technology development Holding Company affiliated with the non-profit AESOP Institute in Northern California. Developing revolutionary, clean, cost effective 24/7 alternatives – designed to replace mobile and fixed power generating and air conditioning equipment. AESOP technology can supersede combustion engines and intermittent solar and wind systems.

Aesop's team has unique experience in managing design and development of complex systems.

THE PROBLEM

Sweltering heat and extreme cold, hurricanes, floods and fire, exaggerated by Abrupt Climate Change, causes human agony worldwide. AESOP technologies will help replace fossil-fuels much faster than existing renewable energy systems.

AESOP Energy SOLUTIONS

Initial products will be extremely efficient Heat Pump air conditioners without HFCs followed by Fuel-Free piston engines, turbines, self-powered Reefer truck refrigerators, and more.

One of three planned operating company subsidiaries: Zero Emissions Energy Inc. This operating company will license AESOP Energy technologies worldwide.

Zero Emissions Aerospace Inc., another future subsidiary, will initially partner with H2 Global LLC to enable aircraft to substitute water for Avgas and jet fuel. Later, ZEA will pioneer unlimited range for electric aircraft.

Ultraconductors Inc. will be a third subsidiary. **Ultraconductors are unique room temperature superconductors. Quora quotes scientists: "The market potential could prove equivalent to the laser, which has generated \$7.5 Trillion in economic activity."**

Potential investors contact me, Mark Goldes, for a generous deal that may save a great many lives. 707 861-9070



AESOP Energy

Contact: Mark Goldes
mark@aesopenergy.com

707 861-9070

AESOP Energy is a start-up technology development Holding Company affiliated with the non-profit AESOP Institute in Sebastopol, California, designing revolutionary, clean, effective, and economically viable 24/7 alternatives to existing mobile and fixed power generating equipment that can supersede combustion engines and intermittent solar and wind systems. Initial products will include Hyper efficient Heat Pump air conditioners requiring only 1/3 the power of existing units and needing no refrigerants - as well as demonstration Aerothermal Ambient Heat Solid-State Generators, Fuel-Free piston engines - and turbines.

Patents will be assigned to Aesop Institute and licensed exclusively to Aesop Energy. More will follow. They cover breakthrough innovative energy technologies. All are inherently cost-competitive. They are readily licensed and mass produced world-wide.

Aesop's team has unique experience in managing design and development of complex systems. Subsidiaries will work in partnership with licensees, corporate allies, partners and subcontractors to bring diverse skills to focused, coordinated projects.

Sweltering heat and cold, hurricanes, floods and fire, made much worse by Abrupt Climate Change, causes agony all across the planet. AESOP technologies will replace fossil-fuels much faster than existing renewable energy systems.

A hyper efficient air conditioner without HFCs or other refrigerants is being prototyped. Fuel-free refrigeration units for trucks are another product - refrigerant free.

First product: Hyper efficient Heat Pump air conditioners.

Technologies will move as rapidly as possible into three planned subsidiaries: Zero Emissions Energy; Zero Emissions Aerospace; and Ultraconductors. Each of these firms is anticipating initial capitalization upwards of \$10m. All will be operating companies offering investors excellent exit strategies.

Executive Management
Mark Goldes, Chairman
Mike Waters, CEO
Karl Frederick, COO
Ken Rauen, CTO
PL, CMO

Value Proposition (Objectives)

Develop Super Efficient Air Conditioners
Develop the world's first 24/7 fuel-free Gen-Sets
License and Joint-Venture worldwide production of fuel-free technologies
Pioneer Room Temperature Ultraconductors and products employing them.
Prototype unique power plants & fuel-free propulsion systems for stationary & vehicle applications - including ships and aircraft.
Joint venture a proven water fuel system to replace gas, diesel & jet fuel.

Competitive Advantages

First producer of decentralized 24/7 solar powered engines - alternatives or supplements to wind and solar panel farms
Cost-competitive extremely efficient refrigerant free Air Conditioners
Fabricators of room temperature Ultraconductors
Alternatives to fossil fuel for vehicles & aircraft

Funding Stage and Amount

Pre-seed Convertible Loans totaling \$250,000 or more
\$5M or more Start-Up Capital

Primary Use of Funds

Working capital to meet existing demand

Exit Strategy

Market appreciation
Establishment of three Operating Company subsidiaries:
Zero Emissions Energy Inc.
Zero Emissions Aerospace Inc.
Ultraconductors Inc.

PROJECTED REVENUE & EARNINGS (000)

	2019	2020	2021	2022	2023
REVENUE	\$3,200	\$18,000	\$86,250	\$411,900	\$2,156,075
EBITDA	\$ 900	\$1,530	\$44,105	\$272,977	\$1,543,325

Company Mission: AESOP seeks to eliminate the expense and the pollution caused by the way energy is used to power human society.

Goals

- Develop and license designs which will replace existing engines and sources of electricity, including the enabling conversion of ambient atmospheric heat, a huge untapped reservoir of solar energy exceeding that of all fossil fuel reserves.
- Introduce commercial applications of practical room temperature Ultraconductors.
- Joint venture conversion of existing engines to substitute water for gas, diesel and jet fuel.

Company Milestones

Prototype Heat Pump air conditioners; fuel-free Gen-Sets, refrigerators for “reefer” trucks & and move into pilot plant production.

Marketing Strategy

- Licensees will include manufacturers and firms of all sizes involved with HVAC & energy systems. Ultraconductor markets will enable Aesop to produce wire, motors and generators. Aesop will develop production technologies in order to enable rapid mass production of these world changing technologies.

A Joint Venture will substitute water for gas, diesel and jet fuel.

Competitive Advantage

- Products incorporating Aesop’s technology will be superior to existing technology and less expensive than the competition. AESOP’s generators will provide cheap green energy 24/7, without fuel, eliminating pollution.

Current Status

- A Rauen extremely efficient prototype Heat Pump air conditioner is in the works. Additional funding is needed and will become available when a pending breakthrough technology is verified and validated. Self-powered demonstration generators will also be prototyped.

The Company anticipates revenue growth from \$3.2M in 2019 to over \$2B by 2023, starting with cash flow from acquisition of two compatible companies.

AESOP Energy seeks accredited investors and strategic partners to assist in expanding this opportunity, both domestically and internationally. AESOP Energy seeks to capitalize on the emerging fuel-free and Ultraconductor technologies that will transform the generation, transmission and storage of electricity.

NOTE: Investors in previous AESOP affiliates will be offered conversion into new equity.

Disclaimer - Forward Looking Statements

This Executive Summary contains Forward-Looking statements that involve a number of risks and uncertainties, including statements regarding the outlook of the Company’s business and results of operations. By nature, these uncertainties could cause actual results to differ materially from those indicated. The Company disclaims any intention or obligation to update or revise any Forward Looking Statements, whether as a result of new information, future events or otherwise.

Company Overview: AESOP ENERGY IS DEVELOPING 24/7 SOLAR POWERED TECHNOLOGY BASED ON AMBIENT HEAT WHICH WILL ALSO AIR-CONDITION A HOME OR OFFICE.

A 24/7 supplement or alternative to solar panels and wind. (Solar panels produce an average of 6 hours of power daily - often requiring costly energy storage).

Ambient heat replaces any need for fuel. This is a huge, untapped, solar energy reservoir, larger than all of earth's fossil fuels.

TOXIC TROLLS ATTACK AESOP's work as fraud and dishonesty. Libelous attacks hinder the raising of working capital. Aerothermal engines will be validated by independent laboratories.

Patented and patent pending technology will provide 24/7 power for everything from buildings and vehicles of every variety including cars, trucks, boats, ships & aircraft.

AESOP's Ultraconductors are room temperature superconductors. (See ULTRACONDUCTORS on this site - 4 Government contracts completed). Technology currently protects aircraft from lightning strikes.

Management Team

Mark Goldes, Founder & Chairman of the Board

Mark is also Chairman & CEO of AESOP Institute. He founded the earlier Aesop Institute affiliates, SunWind Ltd., and later Magnetic Power, Inc., and its subsidiary, Room Temperature Superconductors, which achieved technology breakthroughs in their fields. He has addressed four annual Global Superconductivity Conferences, two National Renewable Energy Laboratory (NREL) Enterprise Forums, and the 2004 Arlington Institute Conference on Breakthrough Technologies for the World's Biggest Problems. He was nominated for the 2006 World Technology Award in Energy. Mark studied Electrical Engineering at the Polytechnic University of NY and California State Polytechnic University at San Luis Obispo. He earned a BA and MA from San Francisco State University and was a Fellow in the Graduate Program in the History of Ideas at Brandeis University, where he earned a second MA degree. See **Bio & AESOP History** on this website for additional information.

MICHAEL WATERS - CEO

Michael Waters is an advanced technology consultant, researcher, inventor and sustainable recovery strategist. He has previously owned businesses in, designed and built: multi-axis robotics, adaptive manufacturing systems, experimental aircraft, custom homes, portable housing systems. In the last fourteen years Mike has researched cutting edge science, technologies and their potential synergistic impact. This has helped established a large collaborative network of researchers and breakthroughs that profoundly affect fields of energy, mining, health, food, water, transportation, housing, sustainable economics and environmental recovery. A primary focus has been energy R&D, working with a diverse group of breakthroughs that combined, uncover new understandings in physics. Mike is currently on the board of a number of organizations involved in advanced energy, mining, agriculture and finance and directly involved in developing a number of energy breakthroughs. Mike's inventions span diverse fields including energy, robotics, fluidics, conservation, aviation and housing.

Karl Frederick, COO

Karl has 30 years of hands-on multidisciplinary management with bottom-line technical, financial, and schedule responsibilities. His program and functional engineering and support organization teams have designed, developed, and produced state-of-the-art systems hardware for operation in extreme physical environments. Karl is also a former Director, Associate Service, for The Conference Board, the world's most quoted private source of management and economic intelligence. He holds bachelor degrees in Electrical Engineering and in the Humanities from the Massachusetts Institute of Technology.

Ken Rauen, CTO

Ken is the inventor of five of Aesop's fuel-free engines. He was a founding member of [New Energy Congress](#). He has hands-on experience with Low Energy Nuclear Reactions and advanced thermodynamics, which is his primary area of investigation. Ken has been issued US patent, [6,698,200 B1](#) for a super-Carnot heat engine. The research behind this revolutionary science has been published in [Infinite Energy](#) magazine, [Issue #52](#). Ken has experimentally verified a macroscopic Maxwell's Demon, which he calls the Proell effect. Two mathematical proofs are publicly available to back up the theory and experimental evidence. Ken has written several articles for [Infinite Energy](#) magazine over the years and has provided peer review of manuscripts and inventions. **His article, co-authored by Bill Harrison in the August, 2014 issue, is an early description of Temporal Wave Mechanics, their proposed replacement for Quantum Mechanics.**

Key Future Partner

H2 Global LLC: Developing inexpensive, easily installed, technology to replace fossil fuels with water - fresh or salt - to run any combustion engine. See: MOVING BEYOND OIL, on this website, to learn more about H2G's exciting work with water as an easy replacement for gas, diesel, or jet fuel in any engine. Water can be extracted from the atmosphere anywhere, using a device on-board the vehicle. No need to refuel!

AESOP Energy Highlights

24/7 solar powered generators will also air-condition a home, office, or factory. Alternative to solar panels and wind - inherently cost-competitive.

Business Plan

Available upon request!

Also, an Article by Ken Rauen that appeared in Infinite Energy Magazine - describing the underlying science - available upon request.

A White Paper re: AESOP's fuel-free piston engines - and other technical information - is available with a signed Non Disclosure Agreement (NDA).

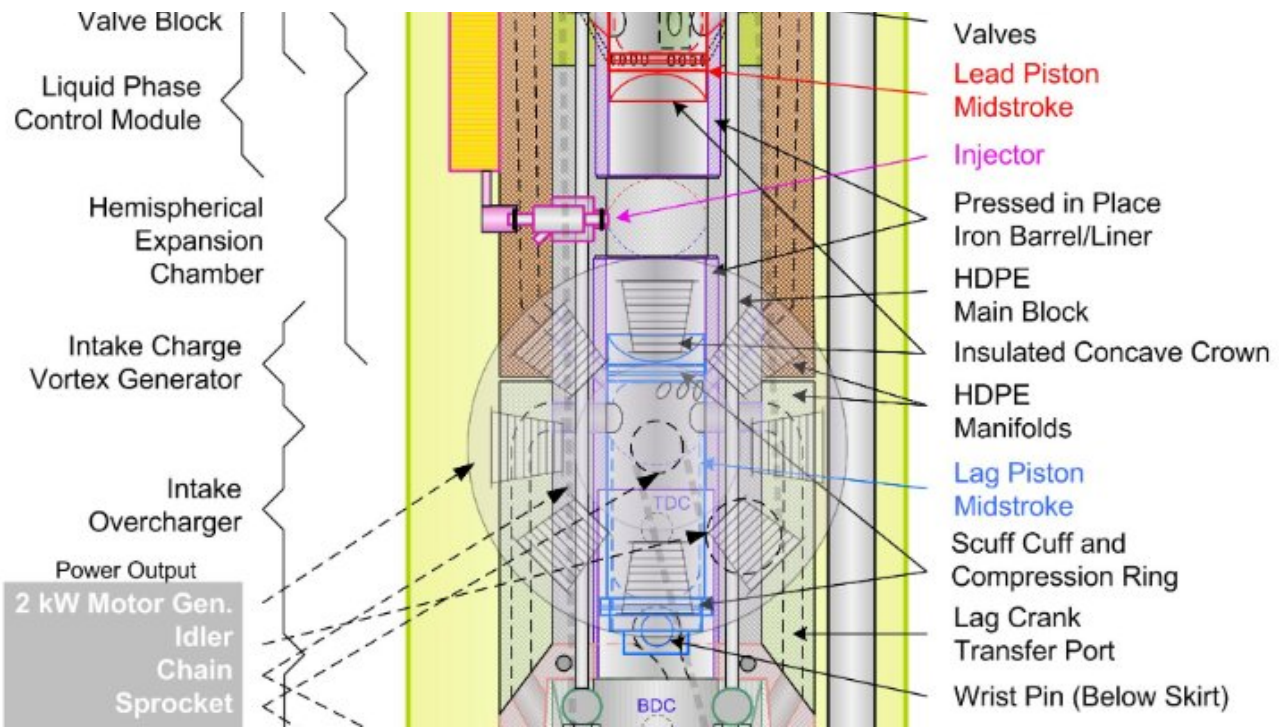

AESOP's 24/7 FUEL-FREE 2 kW GEN-SET

A 24/7 alternative to intermittent solar panels & wind energy.

These engines reflect AESOP's development of the Hunter Cycle. Chris Hunter converted a Ford engine to run without fuel to prove the concept. Hunter Cycle engines are sealed units that contain Propane as a refrigerant. The Propane is not consumed, but merely provides the necessary temperature differential.

Atmospheric (ambient) heat replaces any need for fuel. (Ambient heat is a huge solar energy reservoir, larger than all of earth's fossil fuel reserves).

Frost forms on the engine exterior. The cold air produced will air-condition a home or office.

A Lancet report indicates 9 million pollution deaths per year and \$4.6 Trillion each year in damage! AESOP's zero emissions technology will help reduce this tragic reality.

AESOP: BREAKTHROUGH 24/7 COST-COMPETITIVE GREEN ENERGY SYSTEMS

ALL AESOP generators will run 24/7 (without fuel) using ambient solar energy. Production will provide a continuous alternative to rooftop panels.

AESOP's proprietary technology can scale and reduce the need for fossil fuels, wind and solar farms, as well as provide self-powered air-conditioning & heating units.

AESOP's Ultraconductors are Room Temperature Superconductors. Applications include motors, generators, wire and energy storage.

AESOP: 24/7, Cost-Competitive, Power & Propulsion, Fuel-Free Technologies

AESOP has almost completed a Tecumseh engine conversion to demonstrate 24/7 operation using *only* ambient heat.

AESOP - THE FUTURE OF ENERGY

\$6 TRILLION ANNUAL ENERGY MARKET: Developing Fuel-Free 24/7 solar powered technologies - simpler, less-expensive, faster alternatives to fossil & nuclear fuels, solar panels, solar & wind farms.

Major Capital: Breakthrough energy conversion systems (to be tested and validated by a distinguished independent laboratory) will release very substantial funds,

AESOP: Ground-Breaking new science increases the odds for human survival on our dangerously warming planet!

AESOP's breakthrough technology will make a difference!

PROOF: A Ford engine conversion by Chris Hunter proved the Fuel-Free concept. He is now converting a Kia engine



CHRIS HUNTER STORY

Chris Hunter is a brilliant inventor based in Alaska. After 10 years, countless experiments and considerable money, Chris proved the potential of Ambient (solar) heat to run a Ford engine - without need for fuel. See NO FUEL PISTON ENGINES on this site and scroll down to the last few pages for details. When completed, his newly converted Kia engine will be certified at an official Alaska state laboratory.

AESOP's engine conversion utilizes propane as a refrigerant (as per Chris Hunter's engine.) In development: Proprietary Rauen engines and solid-state power generation technology with a wide variety of applications.

Ken Rauen's engines (patent pending) and super efficient heat-pump technology require *no propane or other refrigerant*. Self-powered Fuel-Free refrigerators for "reefer" trucks can be an early product. AESOP will also introduce a **propane free Rauen** 4 cylinder engine. These 24/7 engines can scale in size, an alternative to wind power. See: NO FUEL PISTON ENGINES on this website.



FUEL-FREE CONVERSION: TECUMSEH

AESOP has completed conversion and was testing a Tecumseh engine to run without fuel. A Mitsubishi V6 engine may follow. These modified engines (followed by proprietary piston and turbine engines) (see opening page and below) will run 24/7 on Atmospheric (ambient) Heat.

Website Contents:

AESOP PERSPECTIVES

NO FUEL PISTON ENGINES: Conversions & Newly Designed Engines

MOVING BEYOND OIL: Water replaces fossil fuels – unlimited range EVs

BIO + AESOP INSTITUTE HISTORY

CHEAP GREEN 24/7: Fuel-Free Generators, Air Conditioners & much more

(Under **MORE**): **ULTRACONDUCTORS: Updated to include motors for electric aircraft; FUEL-FREE TURBINES; SECOND LAW SURPRISES; SECOND INCOMES; HUMANITY IS GETTING VERRRY CLOSE TO EXTINCTION; AESOP's BROOKLYN PROJECT; HUMAN SURVIVAL; UNIQUE POTENTIAL; SOLAR STORM THREAT; BLACK SWANS; ARTICLE** by Michael Brandt, Ph.D.

A JOINT VENTURE WILL PRODUCE EARLY CASH FLOW! A proprietary novel method of creating printed circuit boards has been invented. Cost: 10% of the competition. Production is under way.

FUTURE 4 CYLINDER PISTON ENGINE DESIGN (Sketch & similar design)

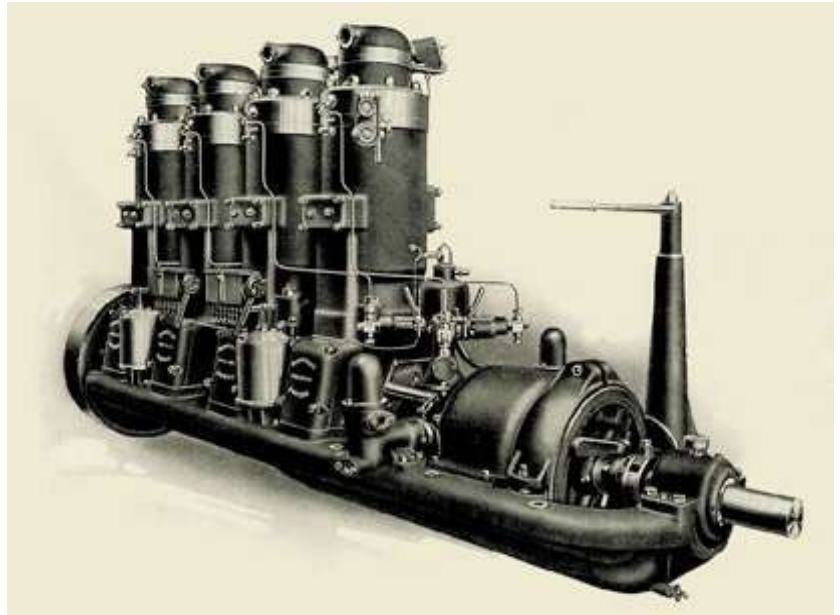
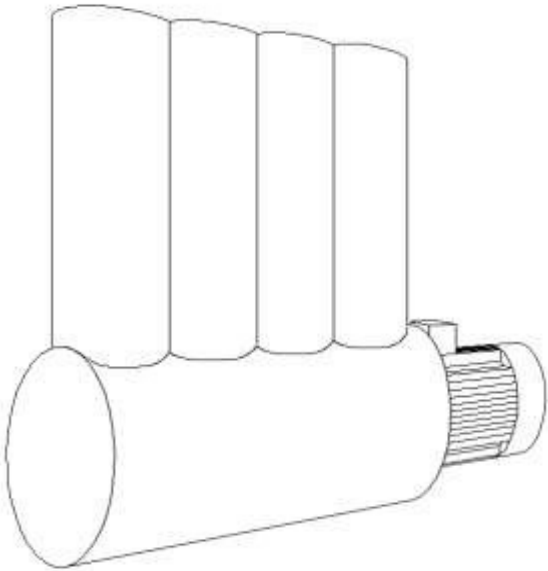

RAUEN FUEL-FREE 4 CYLINDER ENGINE 4 CYLINDER DIESEL ENGINE EXHIBITS DESIGN SIMILARITIES

PHASE TWO:

AESOP Energy is designing a prototype proprietary Rauen fuel-free piston engine. A demonstration engine for a self-running “reefer” refrigerator prototype for trucks will prove the concept. Commercial gen-sets rated at 1 kW, 10 kW & 150 kW will follow. Rauen engines, based on the Proell Effect, need no propane refrigerant. Rauen fuel-free piston engines will replace existing engines that burn fuel. Rauen turbines can power electric aircraft, providing unlimited fuel-free range. Zero Emission Aerospace Inc. will Joint-Venture conversion of existing aircraft to run on water instead of gasoline or jet fuel. See MOVING BEYOND OIL on this website.

AESOP Energy will also develop HFC free window air conditioners - and several more fuel-free engines - each designed to run 24/7 on atmospheric heat (“heat of ambient air”). When propane is employed, it is not consumed, but instead creates the necessary internal temperature differential required for certain varieties of these engines to function. Designs based on the Proell Effect do not require internal refrigerant. The background temperature of space is -455

degrees F. Note: 50 degrees F. on Earth is more than 500 degrees higher. Our atmosphere is a gigantic solar energy storage system. Unlike traditional engines, these engines do not pollute the environment or employ scarce and costly resources. AESOP engines have no combustion. They replace fuel with the heat contained in the surrounding air, thus some of these engines will provide air-conditioning as a bonus (and a few as a primary product). *Designs needing no refrigerant will provide fuel-free window air conditioners.*

Ductless Heating & Cooling Systems Market worth 78.62 Billion USD by 2021.

Ken Rauen's engine concept, U.S. Patent #6,698,200 (and Chris Hunter's pioneering conversion of a FORD engine) both have demonstrated the Second Law of Thermodynamics requires modification. See SECOND LAW SURPRISES under MORE on this website.

See Heading under MORE - AESOP'S "[UNIQUE POTENTIAL](#)"

Applications:

- Off-grid, and emergency GenSets**
- Electric power and air conditioning**
- Heat pumps to supply heat and cooling**
- Multiple uses for every household & business on the planet**

Practical & Affordable:

- Many manufacturing firms can license - and parallel present production!**
- No fuel of any kind needed - ever!**
- Fossil fuels may be superseded! Fast!**

The AESOP engines are low to medium tech and will be inherently inexpensive to manufacture.

R&D development time and materials to prove the practicality of each new model is expected to be relatively fast and reasonable in cost.

All current heat engines, as well as thermoelectric and thermionic solid-state devices, are Carnot-limited. Each has an actual efficiency far below its Carnot efficiency. They must reject heat as a waste product. AESOP engines are the first examples in history which are not Carnot-limited!

See also SECOND LAW SURPRISES - under MORE on this website.

Ken Rauen, inventor of AESOP's Fuel-Free Engines, at an Energy Congress



5 minute VIDEO introducing AESOP Engines at the opening of his presentation:
(Ken speaks after 2:24 Intro)

<https://www.youtube.com/watch?v=EgomeR1TgXU>

“The Next Decade Will Decide What the World Looks Like for Thousands of Decades to Come.” Bill McKibben

Will We Miss Our Last Chance to Save the World From Climate Change?

"We have not hit the disastrous level," says leading climate scientist James Hansen. "But we are close."

<http://www.rollingstone.com/politics/features/will-we-miss-our-last-chance-to-survive-climate-change-w456917>

“...this is a war on your children’s future, a war on human civilization.” *Joseph Romm*

“Climate collapse demands a supply of energy that is far cheaper than fossil fuels, resistant to bad weather and natural disaster, and sustainable in fuel inputs and pollution outputs.” *Carl Page*



Mitsubishi-Chrysler V6 prototype engine being converted to 24/7 fuel-free operation. Substituting atmospheric (ambient) heat, a huge untapped reservoir of solar energy, for fuel.



Humanity's goal must be an 80% decline in fossil fuels, as soon as possible, on an emergency basis! Past emissions are likely to heat Earth by more than 1.5 degrees C. **We are well on our way to 2 degrees C near-term, about the maximum for human life to flourish.** Present efforts cannot prevent this little recognized threat to human existence. Urgent action - combined with cost-competitive **breakthrough** technology - is needed NOW. Assist if you can!

See **HUMAN SURVIVAL** on this website for an overview of humanity's situation. New science capable of providing cheap continuous power is necessary to keep earth livable!

An Arctic Methane Heat Wave plus Global Warming is claimed to be an imminent threat to human existence (*See Arctic-news & chart below*).

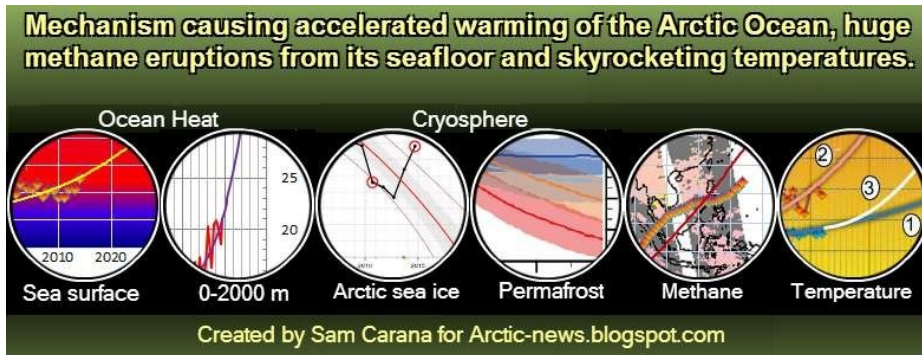

AESOP's Fuel-Free Cutting Edge Technology could help end world dependence on fossil fuels and **eliminate the need for any new pipelines.**

\$5.3 Trillion in subsidies worldwide for fossil fuels in 2015!
(*International Monetary Fund - Working Paper - WP/15/105 - May, 2015 - Page 30*)

Cost of oil subsidies to the average U.S. taxpayer per year: \$5,737.

"In science one tries to tell people, in such a way as to be understood by everyone, something that no one ever knew before." *Paul Dirac, Nobel Prize, physics*

"Always listen to the experts. They will tell you what can't be done and why. Then just do it." *Albert Einstein*

"All truth passes through three stages. First, it is ridiculed, second it is violently opposed, and third, it is accepted as self-evident." *Arthur Schopenhauer 1788-1860*

AESOP's Goal: Fast replacement of fossil fuels.

AESOP is developing Disruptive Breakthroughs. Included are Fuel-Free converted gasoline piston engines to convincingly demonstrate proof of concept. Patent pending 4 cylinder atmospheric heat-driven NO FUEL PISTON ENGINES will follow. *A small engine is in the works - and is expected to prove easy to manufacture.* Next: A window air conditioner and a refrigerator for reefer trucks and containers - both requiring no refrigerant! Then a pair of FUEL-FREE TURBINES. In addition to tapping atmospheric heat, the turbines employ atmospheric pressure. Breakthrough solid-state devices and Fuel-Free micro-turbines will provide unlimited range for automobiles. Income from cars: V2G (Vehicle-to-Grid) Fuel-Free engine equipped cars, trucks and buses, will be able to power homes and sell substantial amounts of electricity to utilities when parked and coupled to the grid. They will also be able to power buildings - a source of ongoing income. (See: V2G - MOVING BEYOND OIL- on this site).

BRIEF SUMMARY OF THE RAUEN PISTON ENGINE INVENTIONS

These inventions go beyond the prior art by totally converting heat from an energy source into mechanical work, allowing an engine of the present invention to interface with only one thermal reservoir. When only one thermal reservoir is required, the heat source can be the traditional heat sink, the environment. Heat inside the engine is converted into work, the engine becomes cold, and heat flows from the environment into the engine according to the correct interpretation rather than the traditional understanding of the Second Law of Thermodynamics.

The Second Law of Thermodynamics has limitations on its applicability, just as Quantum Mechanics showed that Newtonian Mechanics did not apply on the atomic scale. The Second Law does not universally apply to heat engines, as previously believed. There are conditions under which the Second Law does not apply, where the randomness of heat, identified by the Kinetic Theory of Heat and Statistical Mechanics, is not random in its conversion into work. The general scientific explanation behind this invention of the non-universality of the Second Law of Thermodynamics has been conceptually and experimentally proven and published as the Proell Effect, though not yet widely accepted in the mainstream scientific community.

These inventions, different from the inventor's earlier U.S. Patent: No.6,698,200, which is based upon the Proell Effect, aim to approach 100% conversion of heat into work, are inspired by the contemporary work of Chris Hunter and pioneering ideas of Jacob T.

Wainwright in the early 1900s. Like Sadi Carnot's first arguments for the Second Law of Thermodynamics in 1824, Wainwright's ideas were incomplete and partly incorrect, but Wainwright's ideas provided the inspiration for this invention.

The inventions correct and complete the theoretical concepts initiated by Wainwright.

The video that follows is an interview with the late Eugene Mallove, founder of Infinite Energy magazine. As noted in Ken Rau's brief biography below, he worked with Gene for some years. Anyone interested in the rejection of new science – led by the academic community – will find this interview of interest. Mallove was killed shortly after this broadcast when he interrupted a burglary.

https://www.youtube.com/watch?v=NYIK_OpxiZw&feature=youtu.be

Prototype piston engines are under development by AESOP. A prototype Fuel-Free turbine will follow.

[Ultraconductors](#), another major breakthrough, include proven polymer equivalents of room temperature superconductors. Motors and generators are on the horizon featuring Ultraconductors instead of copper windings. Wire, energy storage and cable will follow.

NAYSAYERS: Throughout history naysayers are quick with ridicule and derision. **Physicist Lord Kelvin:** “Heavier-than-air flying machines are impossible and x-rays a hoax”. Many physicists said Magnetic Resonance Imaging (MRI) could not detect cancers. Raymond Damadian, inventor of the MRI said: “Criticism and skepticism come with the territory of invention and innovation. **The bolder the innovation, the harsher the criticism.**”

Every fact of science was once damned. Every invention was considered impossible. Every discovery was a nervous shock to some orthodoxy.

Every artistic innovation was denounced as fraud and folly. The entire web of culture and 'progress,' everything on earth that is man-made and not given to us by nature, is the concrete manifestation of some man's refusal to bow to Authority. We would own no more, know no more, and be no more than the first apelike hominids if it were not for the rebellious, the recalcitrant, and the intransigent. As Oscar Wilde truly said, 'Disobedience was man's Original Virtue' - *Robert Anton Wilson*

NIKOLA TESLA: “*In this present world ...a revolutionary idea or invention is hampered in its adolescence – **by want of means**, by selfish interests, pedantry, stupidity and ignorance. It is attacked and stifled, and passes through bitter trials and tribulations. ... All that was great in the past was ridiculed, condemned, combated, suppressed, only to emerge all the more powerfully, all the more triumphantly from the struggle.*”

“If ...new energy technologies were to be set free world-wide, the change would be profound; it would affect everybody: it would be applicable everywhere. These technologies are absolutely the most important thing that has happened in the history of the world.” *Brian O’Leary, Ph.D.*

AESOP Energy LLC is an AESOP Institute commercial affiliate. This Holding Company will remain privately held.

Three subsidiaries are presently planned. One, **Zero Emissions Energy Inc.** will commercialize all types of generators that need no fuel.

A second, **Ultraconductors Inc.** will prototype and complete development of the motors and generators; wire and energy storage and eventually transmission line cable, that can utilize ambient temperature Ultraconductors.

Magnetic Power Inc. and Room Temperature Superconductors Inc., earlier affiliates, successfully completed four Small Business Innovation Research - SBIR Contracts - with the U.S. Air Force and the Ballistic Missile Defense Organization.

The third, **Zero Emissions Aerospace Inc.** will pioneer aircraft propulsion systems that employ room temperature Ultraconductors and other unique technology that will first replace Avgas & jet fuel with water - and later, for new aircraft, eliminate any need for combustion engines.

AVAILABLE: Final Reports covering each of the four Small Business Innovation Research (SBIR) Contracts (providing proof of the Superconductor achievement) have been cleared for public release. Copies of all four Reports are available, upon request, as pdf files.

Polymer Room Temperature Superconductors – Near-Term Applications USAF Phase I

Polymer Room Temperature Superconductors – Thick Film & Wire Applications Phase II

Development of Significantly Higher Thermoelectric Efficiency Using Ultraconductors

Patterning of Highly Conductive Microstructures in Ultraconductors – (tape, wire, etc.)

Request one or more via email. *Mark Goldes* mark@aesopenenergy.com

World Energy Markets total \$6 Trillion in annual revenue. A recent study estimates global revenue for advanced energy at \$1.3 Trillion with sector growth double the rate of the global economy. \$90 Trillion is the estimated cost to replace fossil fuels worldwide within the next 15 years.

NIKOLA TESLA: Born in Croatia in 1856, emigrated to the USA in 1884; destined to become one of the greatest inventors of advanced technology

that the world has ever known. In 1900, Tesla published “The Problem of Increasing Human Energy” In that essay he mentions the possibility of building a machine powered by the “heat of the ambient air”. He visualized this as “the ideal way of obtaining motive power” from the sun; an endless source of clean power, available everywhere, 24 hours a day.

JACOB WAINWRIGHT: In 1902, Jacob Wainwright, a Civil Engineer, predicted freedom from fossil fuels. His papers (ignored at the time) showed how atmospheric heat could replace fuel. Inventor Ken Rauhen reviewed Wainwright’s papers. AESOP’s Rauhen engine program was inspired by Wainwright’s pioneering work which led to a new, practical, design. (The engine that Rauhen patented previously, U.S. Patent 6,698,200, while not commercially practical, proved a new interpretation of The Second Law of Thermodynamics). [See: NO FUEL PISTON ENGINE and SECOND LAW SURPRISES](#) (scroll down to The Proell Effect: A Macroscopic Maxwell's Demon). This INFINITE ENERGY Magazine article is available upon request.

Jacob Wainwright published several papers, including the one referred to above, early in the last century, pointing out how atmospheric heat could replace fuel. [Had Wainwright been taken seriously, his errors and omissions corrected earlier, engines running on atmospheric heat instead of fuel might have been in production 100 years ago.](#)

Imagine the lives lost to the pursuit of oil, the trillions of dollars that might have been saved, the broader economic prosperity, and the air pollution and Climate Change that could have been avoided. *Mark Goldes*



Photo: APR

REPLACING DIESEL FUEL:

APR Energy provides 70 MW of diesel power modules with this diesel power plant in South Africa. *Imagine converting this 70 MW power plant using multiple modules of water fueled engines – with the water extracted from the air.* Later, Fuel-free piston engines will replace diesel engines. The diesel gen-set market (15 kW to 6MW) is forecast to reach a total of more than \$200 billion thru 2020.

FROM KEN RAUEN, THE INVENTOR: [We've Done Our Homework](#). "Just as Quantum Mechanics showed that Classical Mechanics was wrong in its description of the atom, it did not disprove Classical Mechanics, but it showed Classical Mechanics has boundaries beyond which it does not apply. The advanced thermodynamics of the environmentally heated engines are showing the same thing about classical thermodynamics: the Second Law of Thermodynamics is not wrong; it just has boundaries which have never been recognized. What is 'wrong' with the Second Law is the belief (not a fact - the Second Law of Thermodynamics has never been proven) that it is universal in scope and absolute in manifestation. The Second Law of Thermodynamics is legitimate, but does not always apply. There are still losses in the environmentally heated engines like all other real devices, and these losses conform to the true application of the Second Law of Thermodynamics. These engines) circumvent the mistaken belief that the Second Law always applies to everything in the universe."

"The new science (which revisits the boundaries of the Second Law of Thermodynamics) is counterintuitive to conventional wisdom. However, [Science is not done](#). All of us still have more to learn. Our work is based upon rigorous adherence to the scientific method, but with open minds to explore where no one has gone before.

...This research will withstand the scrutiny of scientific examination."

AESOP's engines are expected to scale to very large sizes. As part of the AESOP Power Grid Protection Project, diesel engines can be modified to run on water instead of diesel in order to insure adequate cooling water circulation to protect nuclear facilities.

["I know that most men, including those at ease with problems of the greatest complexity, can seldom accept even the simplest and most obvious truth if it be such as would oblige them to admit the falsity of conclusions they reached perhaps with great difficulty, conclusions which they have delighted in explaining to colleagues, which they have proudly taught to others, and which they have woven, thread by thread, into the fabric of their lives." Tolstoy](#)

"The problems of the world cannot possibly be solved by skeptics or cynics whose horizons are limited by the obvious realities. We need men (and women) who can dream of things that never were."
John F. Kennedy

“Nature loves courage. You make the commitment and nature will respond to that commitment by removing impossible obstacles. Dream the impossible dream and the world will not grind you under, it will lift you up.

This is the trick. This is what all these teachers and philosophers who really counted, who really touched the alchemical gold, this is what they understood. This is the shamanic dance in the waterfall. This is how magic is done. By hurling yourself into the abyss and discovering it's a feather bed.”

— Terence McKenna



Evolve and Ascend



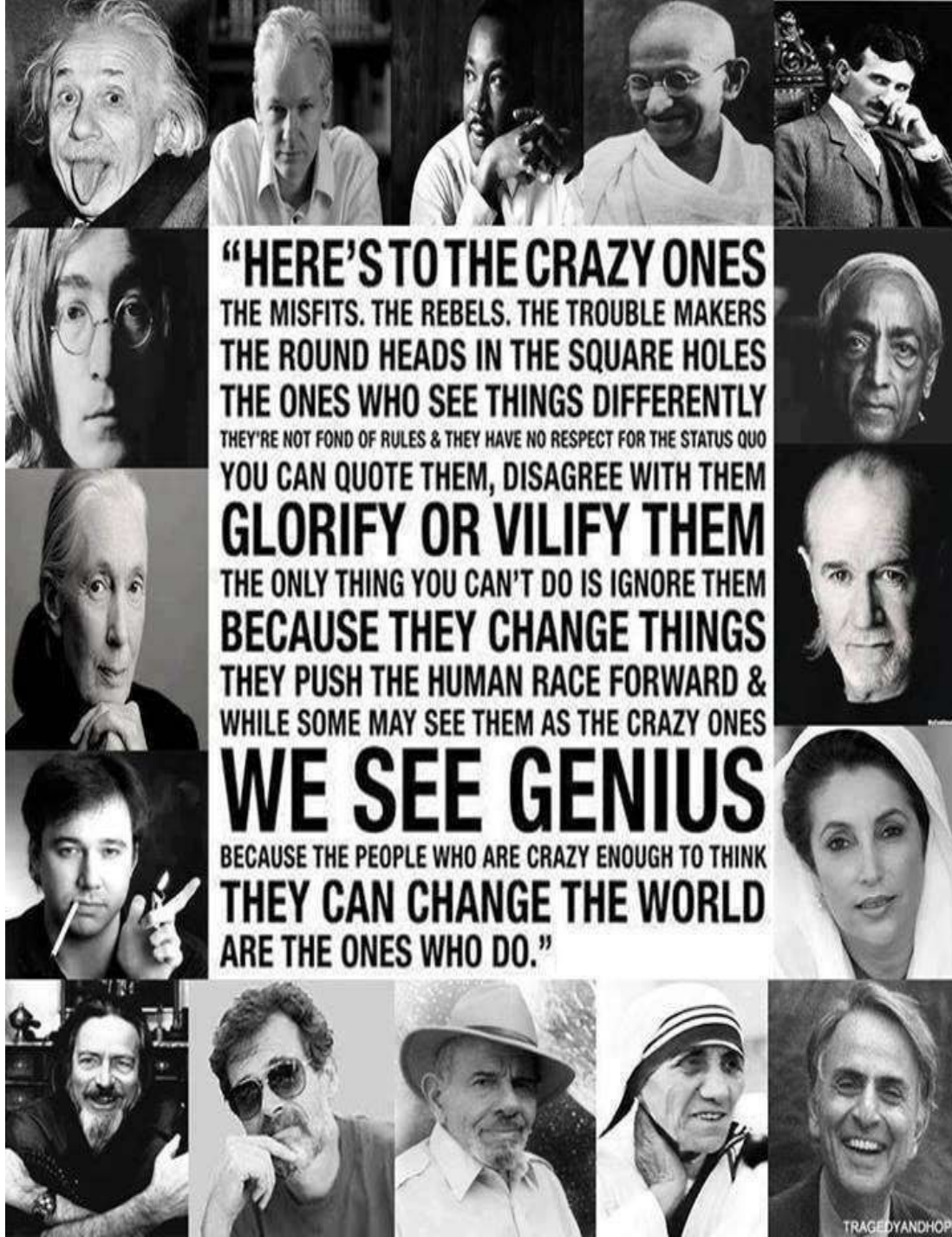

“HERE’S TO THE CRAZY ONES
THE MISFITS. THE REBELS. THE TROUBLE MAKERS
THE ROUND HEADS IN THE SQUARE HOLES
THE ONES WHO SEE THINGS DIFFERENTLY
THEY’RE NOT FOND OF RULES & THEY HAVE NO RESPECT FOR THE STATUS QUO
YOU CAN QUOTE THEM, DISAGREE WITH THEM
GLORIFY OR VILIFY THEM
THE ONLY THING YOU CAN’T DO IS IGNORE THEM
BECAUSE THEY CHANGE THINGS
THEY PUSH THE HUMAN RACE FORWARD &
WHILE SOME MAY SEE THEM AS THE CRAZY ONES
WE SEE GENIUS
BECAUSE THE PEOPLE WHO ARE CRAZY ENOUGH TO THINK
THEY CAN CHANGE THE WORLD
ARE THE ONES WHO DO.”

AESOP Institute is a California non-profit corporation.

AESOP Energy LLC is a commercial affiliate.